

Series 7100 EasyAccess™ Surface Applied Swing Door Operator

Installation Instructions and Owners Manual



G700, 2/91
Revised 3/97

**Horton**
AUTOMATICS

General Conditions

Upon receipt of operator package, verify all operator assembly parts listed on the packing slip are included in the package.

The characteristics of the EasyAccess™ Series 7000 operator allow a fast and successful installation. However, there are several basic details you should know:

When the operator is to be installed on door-by-door or an existing door, it is important that the operation of the door be free and unrestricted. Existing hinges must be good quality and in good working order. The area where the operator is to be installed must be structurally sound and reinforced.

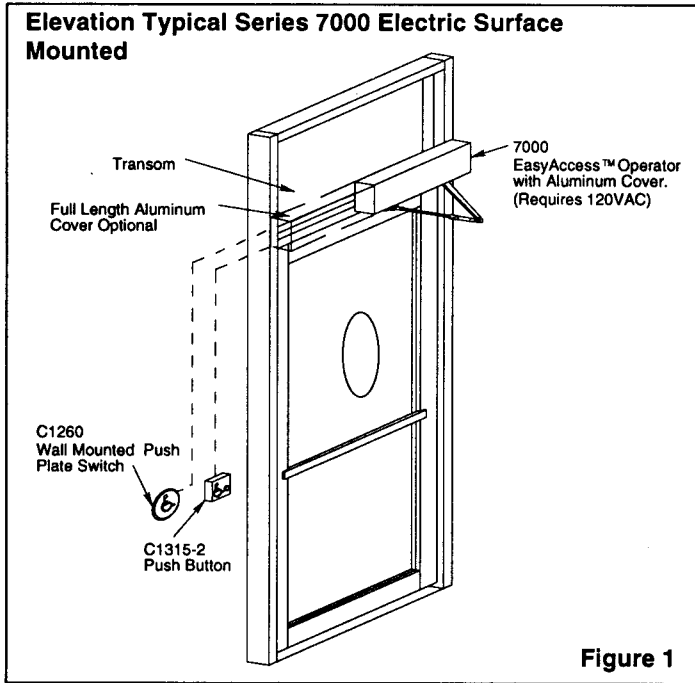

Figure 1

If the operator is mounted on an aluminum/glass door, the glass and glazing must comply with ANSI Standard Z97.1. Should the glass be changed for whatever reason, those changes must comply with the Safety Glazing Code.

All electric wiring must be in compliance with the National Electrical Code.

Electrical input is 120 VAC 60 HZ, 15 AMP service to the operator. The activation circuit is 24 VAC and requires 2 wires to each activating switch.

The EasyAccess operator is part of an operator family called Low Energy in the ANSI A156.19 Standard.

You should be familiar with the ANSI Standard.

Because the operator does not include the conventional safety mat circuit it is very important you don't adjust the operator to open or close to the check position, faster than allowable by the current ANSI Standard A156.19 – See Operator Adjustment Chart, page 9. It is also very important the door be labeled with signs to inform the public the door is an "Automatic Door". See page 10.

The operator is provided with an extruded aluminum cover.

By design, the operator has low power. Consequently, it should not be used as a solution to wind problems.

If the swing door is to meet handicap code requirements, it must have the following: (Figure 2)

1. The door must provide at least a 32" opening.
2. A flat floor area of 5' x 5' should be provided on interior and exterior side of the door opening.
3. The bottom rail of glass doors should be protected to 7 1/2" high. (Some codes require a taller bottom rail.)
4. The threshold must not be more than 1/2 inch high and must be tapered. Disabled persons prefer no threshold.

Select The Proper Hand.

Note: The operators are handed. However they have a universal mounting plate that allows the hand to be changed in the field. For changing operator handing instructions, see H701, a supplemental instruction booklet, in the Horton Automatics Service Manual.

Provide for 120 volt, 15 Amp electrical service to operator.

Operators are approved by UL to include a flexible power cord that will plug into an approved, grounded electrical outlet.

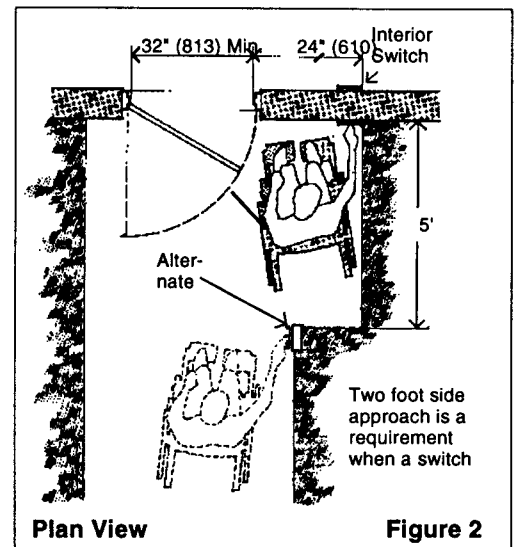

Plan View

Figure 2

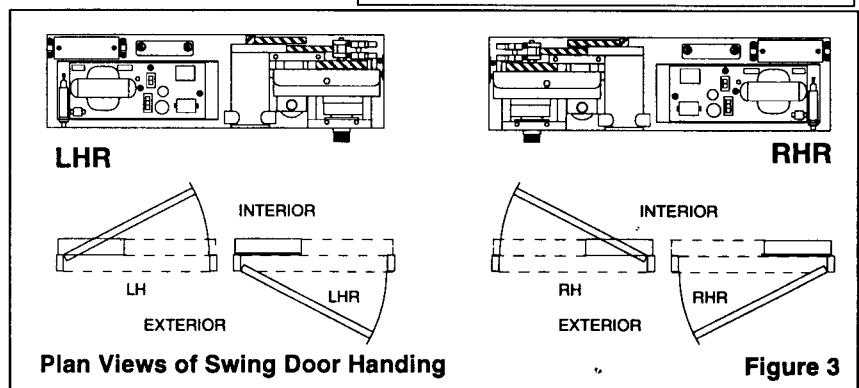

Plan Views of Swing Door Handing

Figure 3

A. Operator Installation – Surface Applied Series 7100

For Series 7500/7800 installation instructions refer, to G700S a supplemental instruction booklet

The aluminum cover is offered in several mounting types and with several different arm configurations. The cover is factory prepared with the exception of the operator spindle cutout. This needs to be done by installer because position may vary according to reveal and hinge type.

Note: Occasionally the job specifications call for a 6" x 6" side load cover. For example of that cover, see Figure 7, page 4.

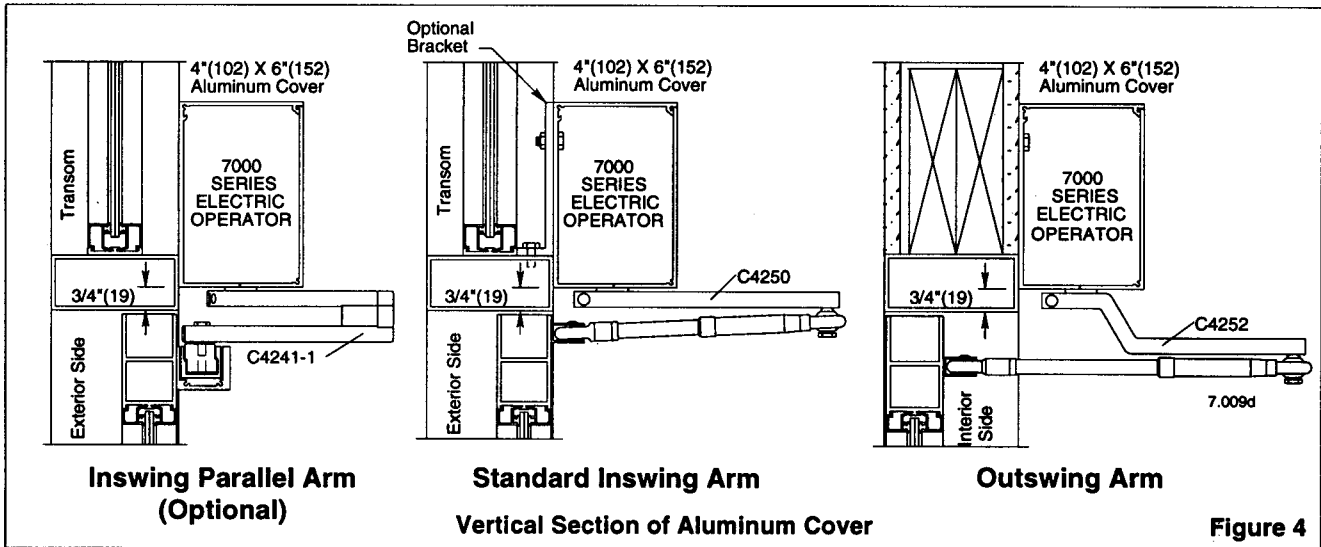

Select Proper Arm from choices below:

Note: C4241-1 Parallel Arm is used on inswing installations with no side room clearance or inswing center pivoted doors with breakout.

1. Cover Preparation

Operators can be ordered with the cover already prepared, if your's is, proceed to #2 below.

Cut cover to proper dimension – door opening plus 3" (1 1/2" lap each jamb). Cut a notch for the operator spindle in the cover backmember and face plate. This notch should be positioned according to Dimension A in the Arm Information Chart on page G700.6 and should include the additional 1 1/2" allowed for overlapping the jamb. You should also drill and countersink the 6 holes used to attach the operator to cover as shown in Figure 5. Attach backmember of cover to frame as shown, (Figure 7).

Note: If there is adequate reinforcement behind the cover, the 3 holes for securing the operator base plate to the C2910 backmember are not needed because you can attach the operator base plate and cover backmember directly to the reinforced wall using #14 x 1 1/2 HHSMS provided. However, the 3 holes for C2911 face plate are required to secure the face plate to the backmember. It may be necessary to secure the faceplate at the end opposite the operator with a method other than the end cap if the end cap is not accessible. (Figure 5)

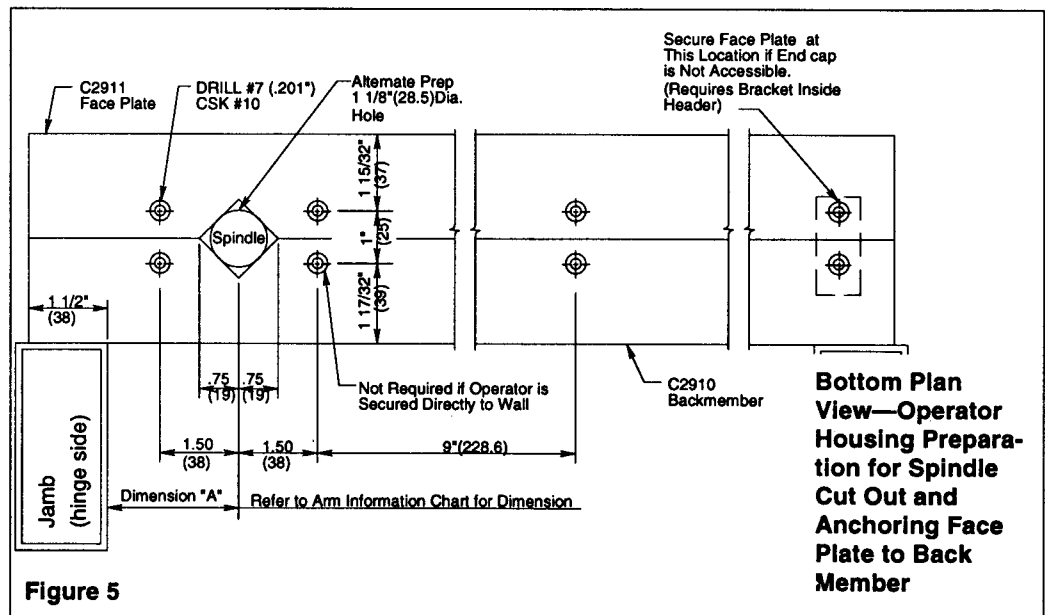

Alternate Cover Preparation from stock lengths

Clamp cover backmember and face plate together. Cut cover to required length, minimum 28". This will allow enough room for all components (even the duplex receptacle) to fit inside cover *and*, if necessary you can shift the operator in the cover and lap the jamb $1\frac{1}{2}$ " on one side for support. On the job site, determine position of operator cover and mark for spindle hole. Clamp bottom of cover together and using a $1\frac{1}{8}$ " hole saw bit, cut a hole for the operator spindle through the cover backmember and face plate. This hole should be positioned according to Dimension A in the Arm Information Chart on page G700.6. If the jamb is lapped don't forget to add $1\frac{1}{2}$ " to the Dimension A number. Secure backmember of operator cover to door frame using screws in the wall above door.

2. Provide for 120 volt, 15 amp Electrical service.

Operators are approved by UL to include a flexible power cord to plug into an approved, grounded electrical outlet. (Figure 6)

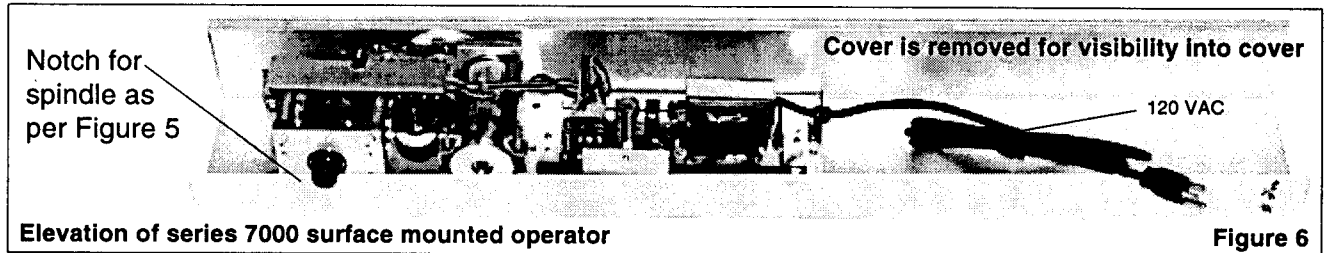

Note: Canadian Standard Association (CSA) and some United States codes require a junction box and conduit into the cover, operators are furnished with a junction box if so ordered. CSA requires an aluminum cover.

3. Mount Cover to Frame

The bottom of the cover should be set $\frac{3}{4}$ " above the top of the door and secured to the wall or door frame. (Figure 4) Using #14 x 1-1/2 HHSMS, mount cover as per Figure 7.

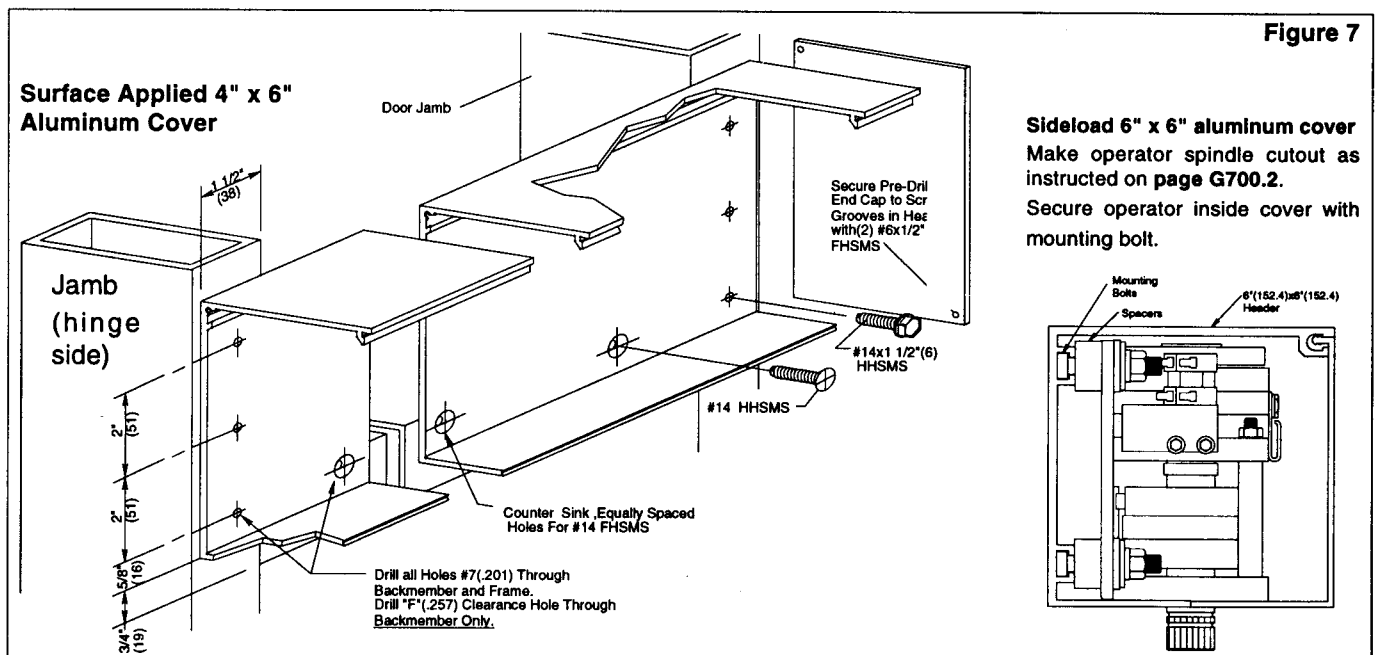

4. Install Operator in Cover

Slip the operator into the cover over the cleat and secure it into place using either the #14 x $1\frac{1}{2}$ HHSMS through the back side of the operator base plate and cover backmember into the reinforcement or using #10-24x $\frac{3}{4}$ " FHMS in the predrilled holes on the bottom side of the cover. (Figure 5)

Refer to Figure 4 for vertical section of operator and arm.

Cover End Caps

The end caps are predrilled for securing to the face plate and backmember. Insert screws through predrilled holes – one (1) screw into 2910 backmember screw spline and one (1) screw into 2911 face plate screw spline.

Tip:

If the end cap is against a wall and will not be accessible, install the end cap to the 2910 backmember before securing the 2910 backmember to the door frame. The face plate is installed as per Figure 5.

5. Install Arm

- Select proper arm size and location from Arm Information Chart on page G700.6.
- Select adjustable connecting arm length from Chart on page G700.6, dimension "C" minus $4\frac{1}{2}$ ". Cut and attach to power arm. (Figure 8)
- Install foot in accordance with Figure 9 at dimension "B". Install connecting arm to foot. See Figure 12 for parallel arm.
- The operator spring is *not* pre-wound, therefore it must be pre-wound so the operator will be under spring force when closed. The following instructions, will allow you to simultaneously set the open stop and prewind the spring.

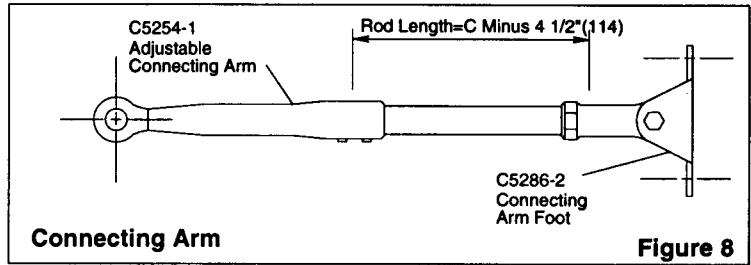

Figure 8

There are two methods to set the power arm at the proper location on the spindle and prewind the spring. Of the two methods, the **Preferred Method** is the most accurate.

Preferred Method

Manually open the door to 90° (or as specified). Energize the operator so the operator rotates the spindle to the full open position against its internal stop; this action simultaneously winds spring. With the connecting arm adjusted to the proper length and connected to the foot, slip the power arm on the output spindle and tighten the

$\frac{1}{4}$ " socket-head cap screw to 10 foot-pounds of torque. Tighten setscrew through side of arm into shaft. Connect power arm to connecting arm with $\frac{3}{8}$ - 24 x $1\frac{1}{4}$ " HHMB and $\frac{3}{8}$ washers. De-energize the operator; it should close against the door stop.

Secondary Method

Manually open the door to 90°. With the foot connected to the door and the adjustable connecting arm attached to the power arm, slip the power arm on the output spindle, but do not tighten. Mark the position of the slot on the output spindle. Remove the arm, rotate 240° and tighten to 10 foot-pounds of torque. A torque wrench is recommended. Now tighten setscrew through side of arm into spindle. Reconnect at connecting arm.

To ensure arm does not walk off the shaft, install screw and washer into predrilled hole in the bottom of output shaft.

Caution: When installing the power arm or when servicing any swing door operator, be sure to keep your face, hands and arms clear of the power arm's swing path. Serious injury could result should the operator be accidentally activated to an open position or should the operator return to a relaxed position.

- A permanent floor mounted stop is recommended for stopping the door in the full open position. This will protect the operator from abuse. When this method is used, ensure the stop does not create a trip hazard.
- Proceed to adjust operator control and cams in accordance with adjustment procedures page G700.9.

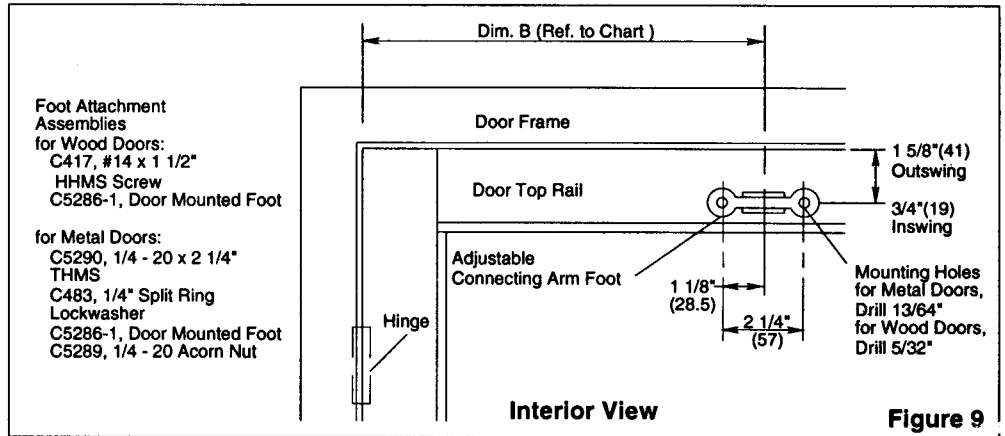

Figure 9

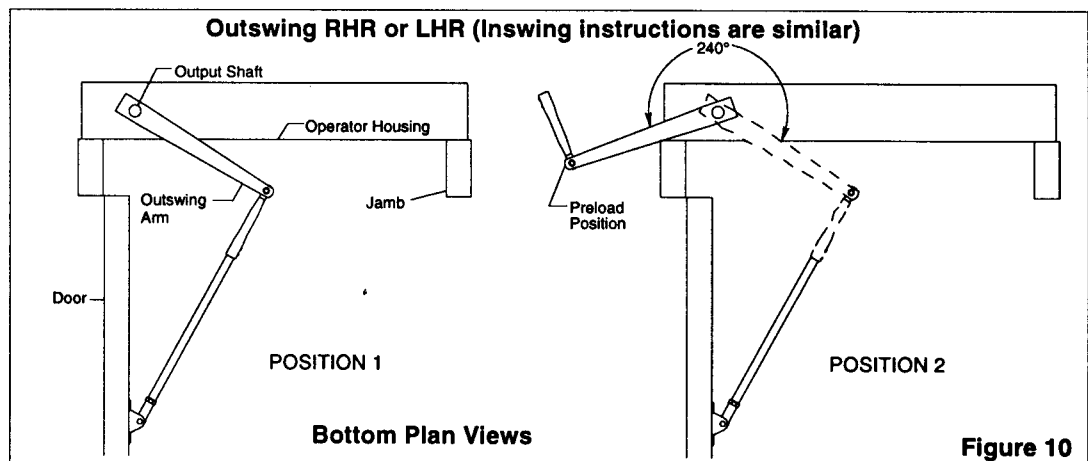

Figure 10

Plan view Arm Connection

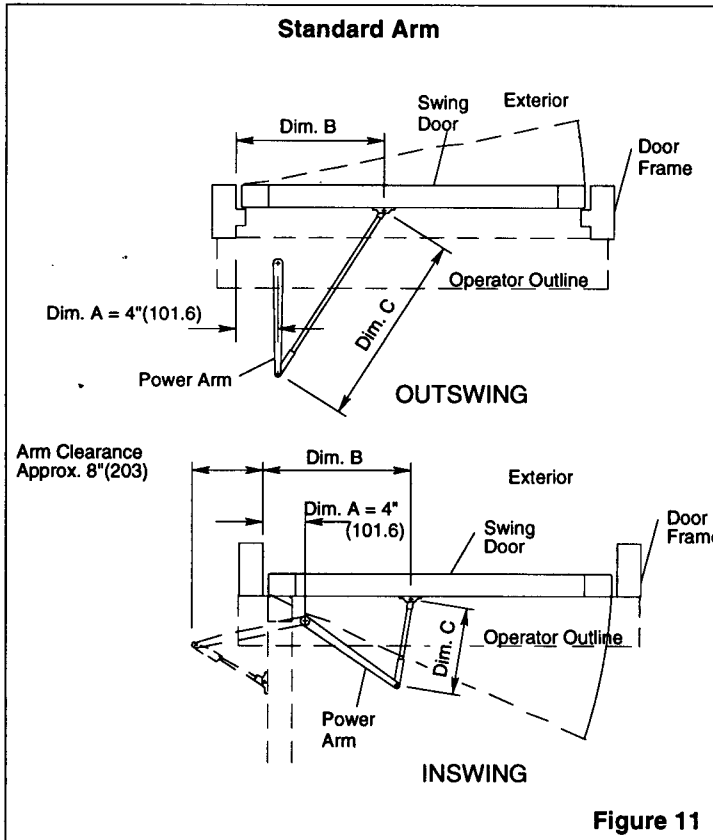

Figure 11

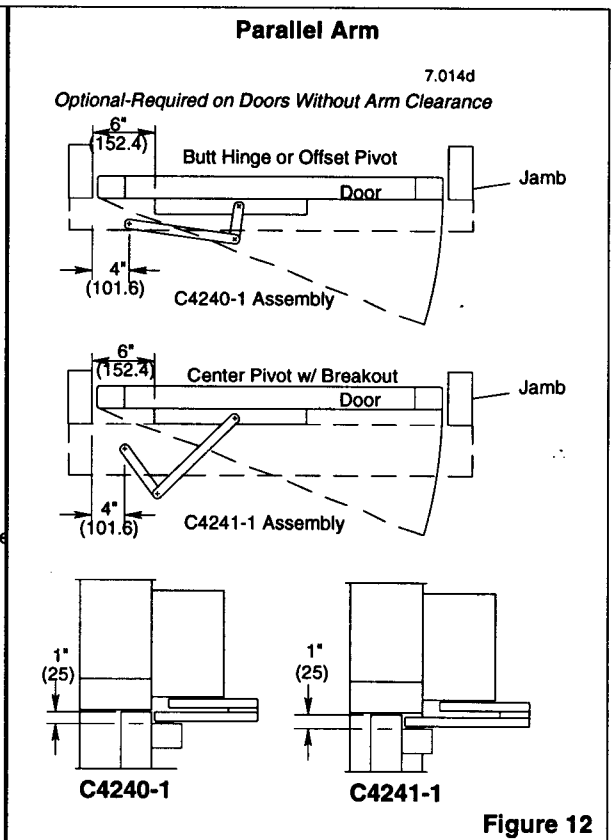

Figure 12

Parallel Arm is required on inswing doors without arm clearance

Arm Information Chart

Reveal	Butt Hinge or Offset Pivot						Center Pivot 2 3/4"					
	Inswing			Outswing			Inswing			Outswing		
	A***	B	C*	A	B	C*	A***	B	C*	A	B	C*
0	4" (102)	13" (330)	10" (254)	4" (102)	16" (406)	17 1/8" (435)	4" (102)	17" (432)	9" (229)	4" (102)	16" (406)	16 1/2" (419)
1/2" (13)	4" (102)	13" (330)	10" (254)	4" (102)	16" (406)	17 1/2" (445)	4" (102)	17" (432)	9" (229)	4" (102)	16" (406)	16 7/8" (429)
1" (25)	4" (102)	13" (330)	10" (254)	4" (102)	16" (406)	17 3/4" (451)	4" (102)	17 1/2" (445)	9 1/2" (241)	4" (102)	16" (406)	17 1/4" (438)
1 1/2" (38)	4" (102)	14" (356)	10" (254)	4" (102)	16" (406)	18 1/4" (464)	4" (102)	17 1/2" (445)	9 1/2" (241)	4" (102)	16" (406)	17 3/4" (451)
2" (51)	4" (102)	14" (356)	10 1/2" (268)	4" (102)	16" (406)	18 5/8" (473)	4" (102)	18" (457)	10" (254)	4" (102)	17" (432)	18 3/4" (476)
2 1/2" (64)	4" (102)	14" (356)	10 1/2" (268)	4" (102)	16 1/2" (419)	19 1/4" (489)	4" (102)	19" (483)	10 1/2" (268)	4" (102)	17" (432)	19" (483)
3" (76)**	4" (102)	15" (381)	10 1/2" (268)	4" (102)	16 1/2" (419)	19 3/4" (502)	4" (102)	19" (483)	10 1/2" (268)	4" (102)	18" (457)	20" (508)
3 1/2" (89)**	4" (102)	16" (406)	11" (279)	4" (102)	16 1/2" (419)	20 1/8" (511)	4" (102)	19" (483)	10 1/2" (268)	4" (102)	18" (457)	20 1/2" (521)
4" (102)**	4" (102)	17" (432)	12" (305)	4" (102)	17" (432)	20 3/4" (527)	4" (102)	25" (635)	17" (432)	4" (102)	19" (483)	21 1/2" (546)

* To determine length of rod reduce C dimension by 4 1/2"
 ** If parallel arm is used consult factory if reveal is more than 2 1/2"

C. Install Activating Switch

1. Install Switch on Wall

It is generally recommended that the switch be installed at a height of 36"– 42" from the floor. Switch location should be placed in plain view of the door. ANSI 117 provides guidelines on switch location. In general, it should not be on the door or door frame. It should be easily accessible to the user. On the swing side, it must be out of the path of the opening door. (Figure 2)

Select the height the switch is to be installed. Place the switch in position and mark the screw hole locations.

Provide a two conductor wire from switch location to operator. Connect wires and secure switch. Connect wires to operator switch circuit terminal (Figure 15). **Do not connect to high voltage.**

2. Options

a. The activating switch can be in a location selected by the owner. However, the switch must be in a place visible to the user and in full view of the door when the door is activated. ANSI A117 standard has guidelines for the mounting location and space requirements for maneuvering.

b. A radio control can be used as an activating device. Delete 2 conductor 24 VAC wire.

C1316-2 Switch Information

Four C57, #10x1" PHSMS are provided to secure the C1316-2 plastic junction box to the wall surface.

Conditions vary with each job. Drill four holes in back of box and attach box with screws.

For recess-into-wall applications, the C517 pushbutton and C1319-1 switch cover can be installed into a standard electrical 4"x4" junction box.

Wall Switch (Push-plate)

The C1260 push-plate wall switch consists of one 6 1/4" diameter brushed stainless steel push-plate and microswitch assembly. The push-plate assembly mounts to a junction box with two Allen type flat head screws (included), which are accessible through two holes in the push-plate.

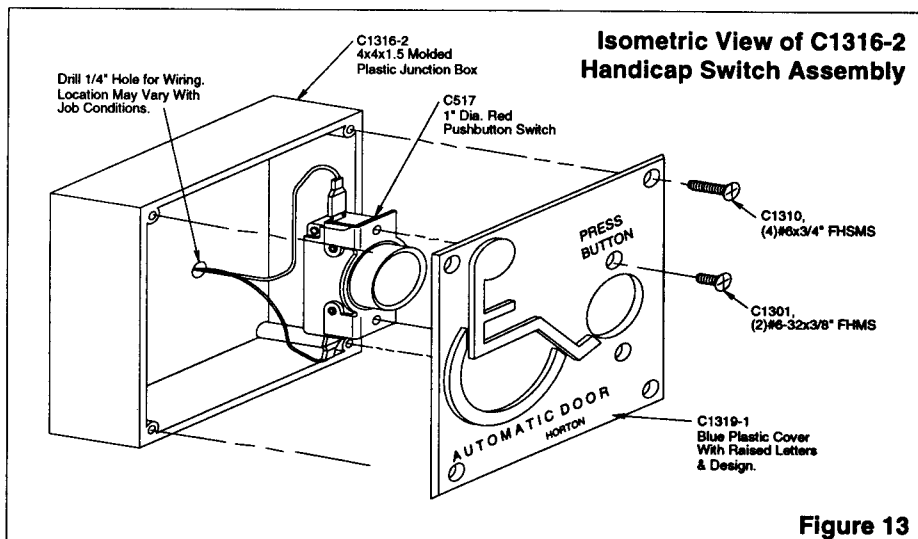

Figure 13

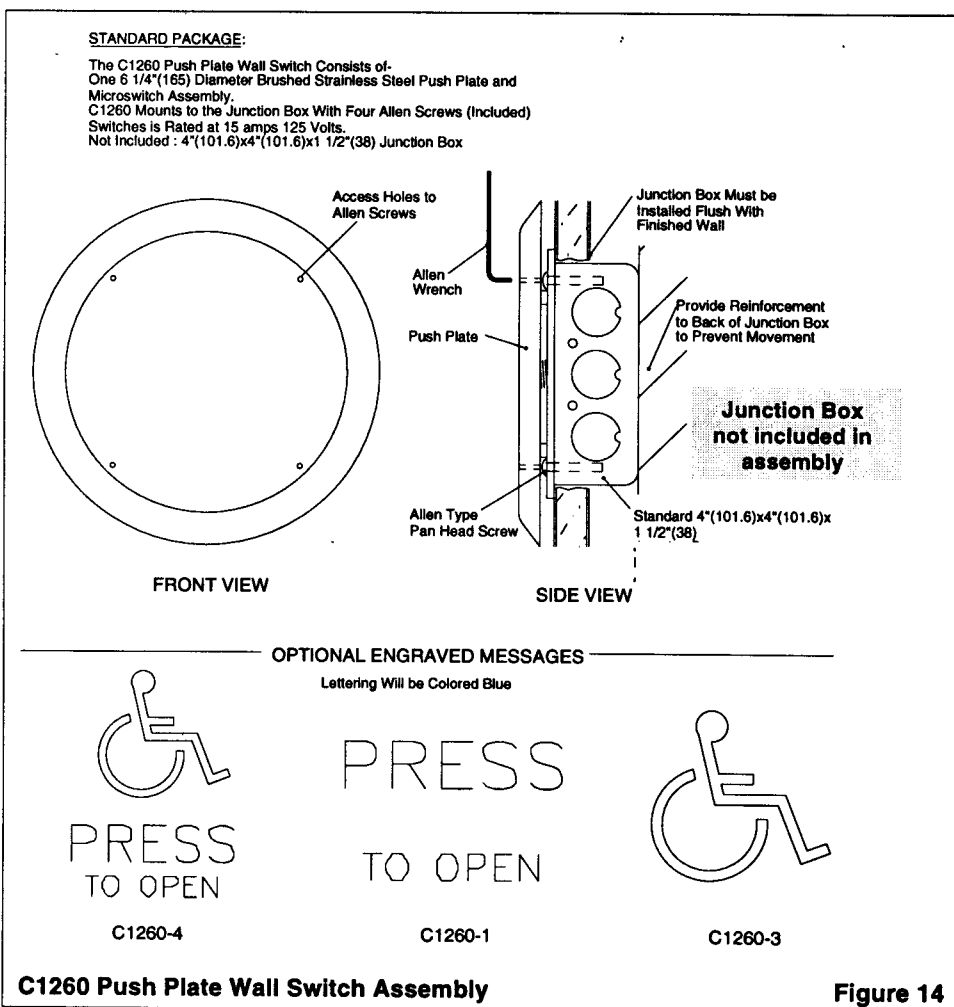
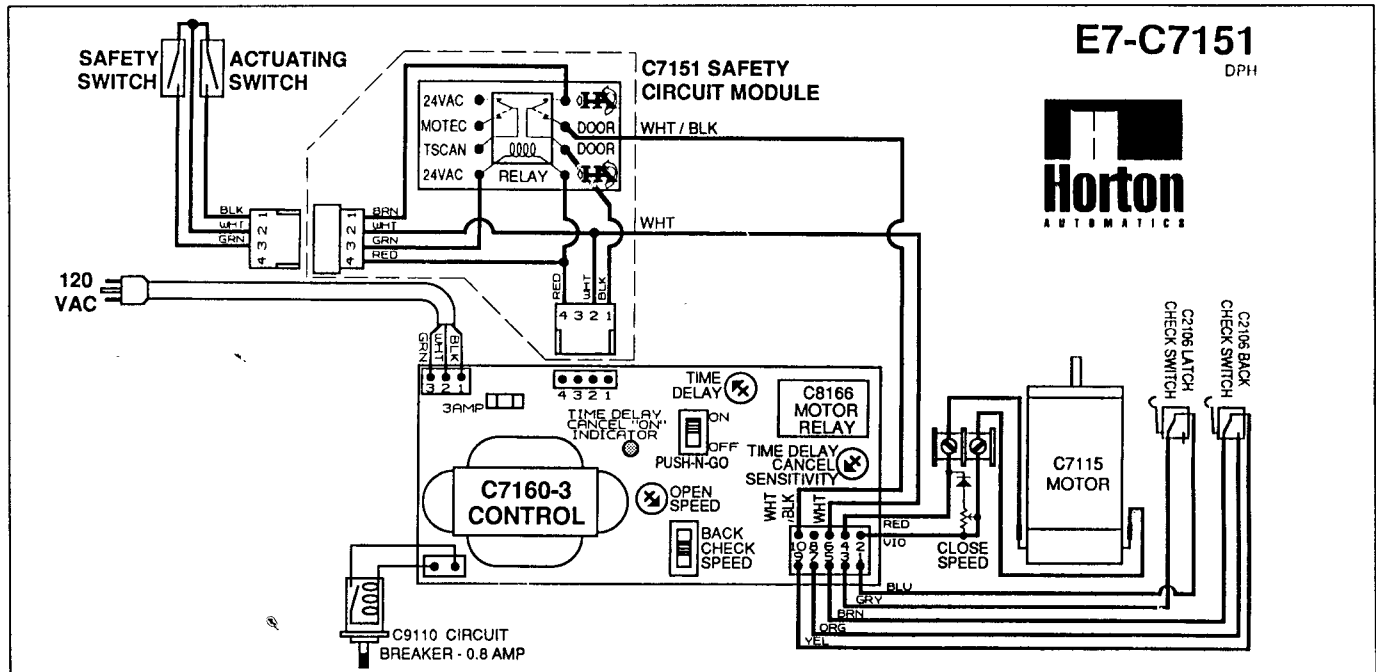
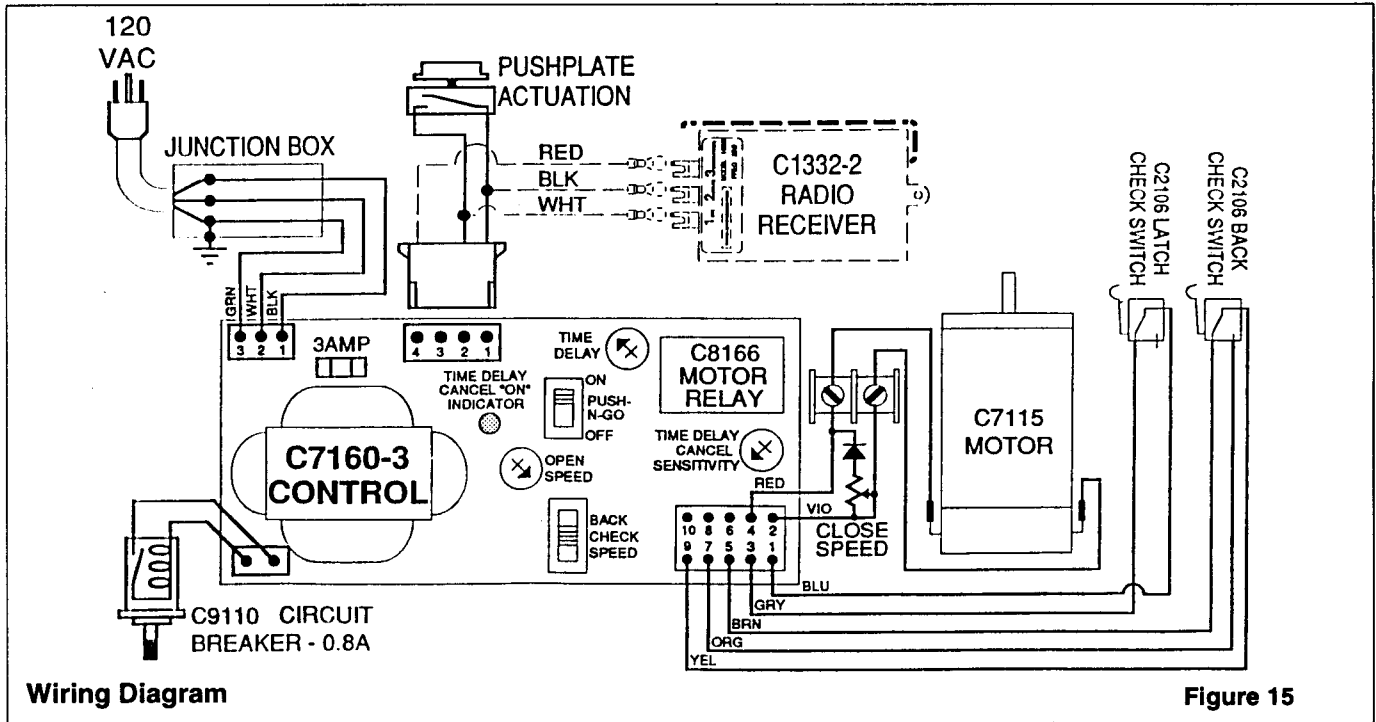

Figure 14

D. Electrical

It is important for the electrical wiring to enter the correct end of the cover.

Caution: All wiring passing operator must be placed in raceway.



1. Install C7151 Circuit Board onto the operator aluminum backplate above the C7160-3 Control and adjacent to the motor using the either the enclosed Velcro™ strips, or the #6 X 1/2" PHSMS screws and spacers provided.
2. Disconnect C9027 Actuating Switch Harness from C7160-3 Control and connect to mating plug in the C7151 Module.
3. Remove the 10-pin plug on the operator harness from the control and insert the White wire (from the C7151) in #6 and the White / Black Stripe wire in #10 of the 10-pin plug. Reconnect the plug to the control.
4. Connect the 4 conductor plug of the C7151 Module to the mating plug in the C7160-3 Control.
5. The Actuating Switch should be connected to the Black and White wires of the C9027 Harness, and the Safety Switch should be connected to the Green and White wires.

Actuation of the Safety Switch first will prevent the door from opening. As soon as the Safety Switch opens, if the Actuating Switch is tripped, the door will open. If the Safety Switch is subsequently tripped, it will continue to hold the door open, and will continue in this function until both switches are open and the control time delay expires, allowing the door to start closed.

E. Adjusting Operator

The following important information is provided as a recommendation for safe operating speed adjustments and should be adhered to when installing or servicing the Series 7000. (Figure 16)

OPENING SPEED (see ANSI Chart)

Doors shall be field adjusted so that opening speed to back check or 80° shall be three (3) seconds or longer.

Opening speed to fully open shall be four (4) seconds or longer.

CLOSING SPEED (see ANSI Chart)

Doors shall be field adjusted to close from 90° to 10° in three seconds or longer as required by ANSI chart above. Doors shall be field adjusted to close from 10° to fully closed in not less than 1.5 seconds.

Unless a sensing device is used to hold the door open, the door shall be field adjusted to remain fully open for not less than five (5) seconds.

The force required to prevent a door from opening or closing shall not exceed a 15 lb ft (67 N) applied one inch (25 mm) from the latch edge of the door at any point in the opening or closing cycle.

The kinetic energy of a door in motion shall not exceed 1.25 lb ft-ft (1.69 Nm). Chart adjustments are in compliance.

In the event of failure, doors shall open with a manual pressure not to exceed 15 lb ft (111 N) at a point one inch (25 mm) from the latch edge of the door. (Varies by local code)

Doors shall be equipped with a sign(s), visible from either side, instructing the user as to the operation and function of the door. (Figure 17)

Time Delay: The operator control includes a variable time-delay adjustment. For doors to be in compliance with the handicap code the door must hold open for a minimum of five seconds before starting to close.

TimeDelay Cancel: The control has a feature that will cancel the opening time-delay when stalled during opening. To access this feature, activate the operator and adjust the potentiometer on C7160-3 so that the time delay cancel LED only turns on when door is blocked during opening. Red LED on C7160-3 will blink when this occurs.

SoftTouch™ Module (C7240)

SoftTouch™ is a module that can be added to the operator. It will reopen the door if the operator is stopped while the door is closing.

ANSI Chart					
Minimum opening time to Open Check or 80° (in seconds) or Minimum closing time from 90° to Close Check or 10° (in seconds)					
Door Leaf Width	Door Weight in Pounds (kg)				
Inches (mm)	100(45.4)	125 (56.7)	150 (68.0)	175 (79.4)	200 (90.7)
30 (762)	3.0	3.0	3.0	3.0	3.5
36 (914)	3.0	3.5	3.5	4.0	4.0
42 (1067)	3.5	4.0	4.0	4.5	4.5
48 (1219)	4.0	4.5	4.5	5.0	5.5

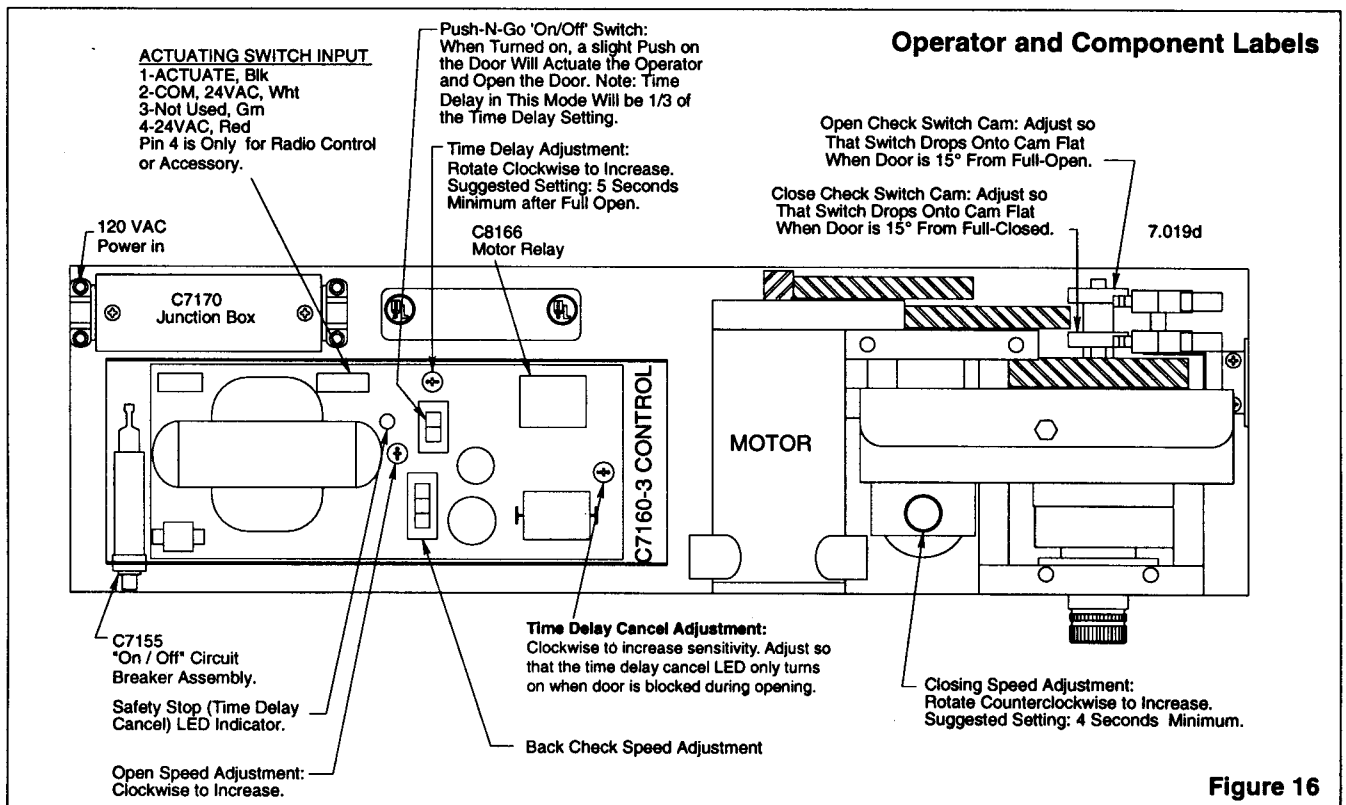

Figure 16

F. Special Notes

1. Safety module

If a safety circuit is required on the Series 7000 EasyAccess Operator add module C7151 to the C7160-3 master control. See page G700.11. A Soft Touch module C7240 that will reopen the door if the operator is stopped while the door is closing can also be added to the operator.

2. Other accessories that may be required

A C7220 electric strike interface – delays the actuating signal to the operator for a short variable time period, giving the electric strike time to unlock and prevent jamming.

Note: Some electric strikes have a bolt-monitor switch that the activating signal can be wired through and this eliminates the need for the strike interface.

3. Simultaneous pairs of operators

Operators in simultaneous pairs can be isolated from each other by using our isolation relay C7215 when independent operation for Push-N-Go is desired.

G. Apply Special Decal

An instruction sign should be mounted on the door at 58" + (plus) or - (minus) 5" from the floor to the center line of the sign and should be visible from both sides of the swing door. The sign should be a minimum of 6" diameter. (Figure 17)

A Daily Safety Check decal (C1690) should be placed on the door jamb in view of owner. This decal tells the owner what needs to be checked. (Figure 18)

H. Changing Operator Hand

See instructions for Changing Operator Hand page G700.13.

I. Instructions To Owner

It is recommended the installer give the owner instructions to acquaint him with the operation of the door, location of related equipment and preventative maintenance requirements.

Literature is shipped with each door. This information should be given to the owner at the instruction session.

Cover at least these items:

1. *Maintenance Manual* (Leave a set of these instructions with owner).
2. Point out location of electrical cutoff switches for door.
3. Advise the owner of the protection circuit against locked door. If the door does not operate, he should check the circuit breaker. If the white band is visible press the button until the band disappears.
4. Horton Automatics suggests the operator gears be lubricated and nuts and bolts tightened every five months on heavy traffic unit – six months on light traffic. Horton Automatics All Weather Gear Lubricant is recommended.
5. Advise owner to check door daily for safety – speed, force and time delay.

Horton Automatics Invoice Number _____

Date Operator Was Placed in Service _____

One-Year Warranty From Date Operator Was Placed in Service.

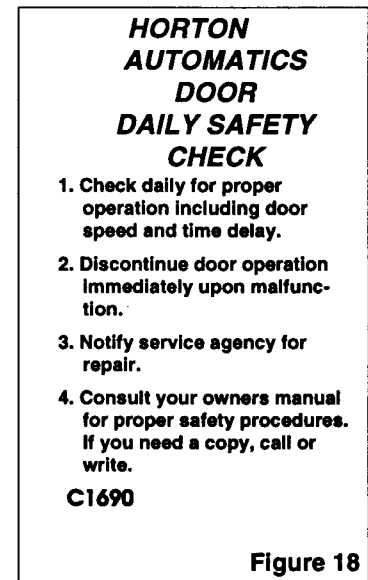
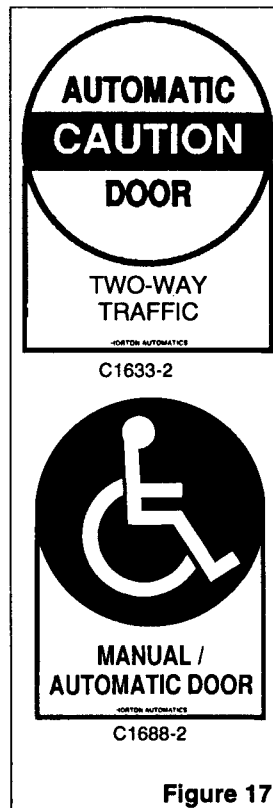

SERIES 7000 GEAR TRAIN ASSEMBLY DIAGRAM

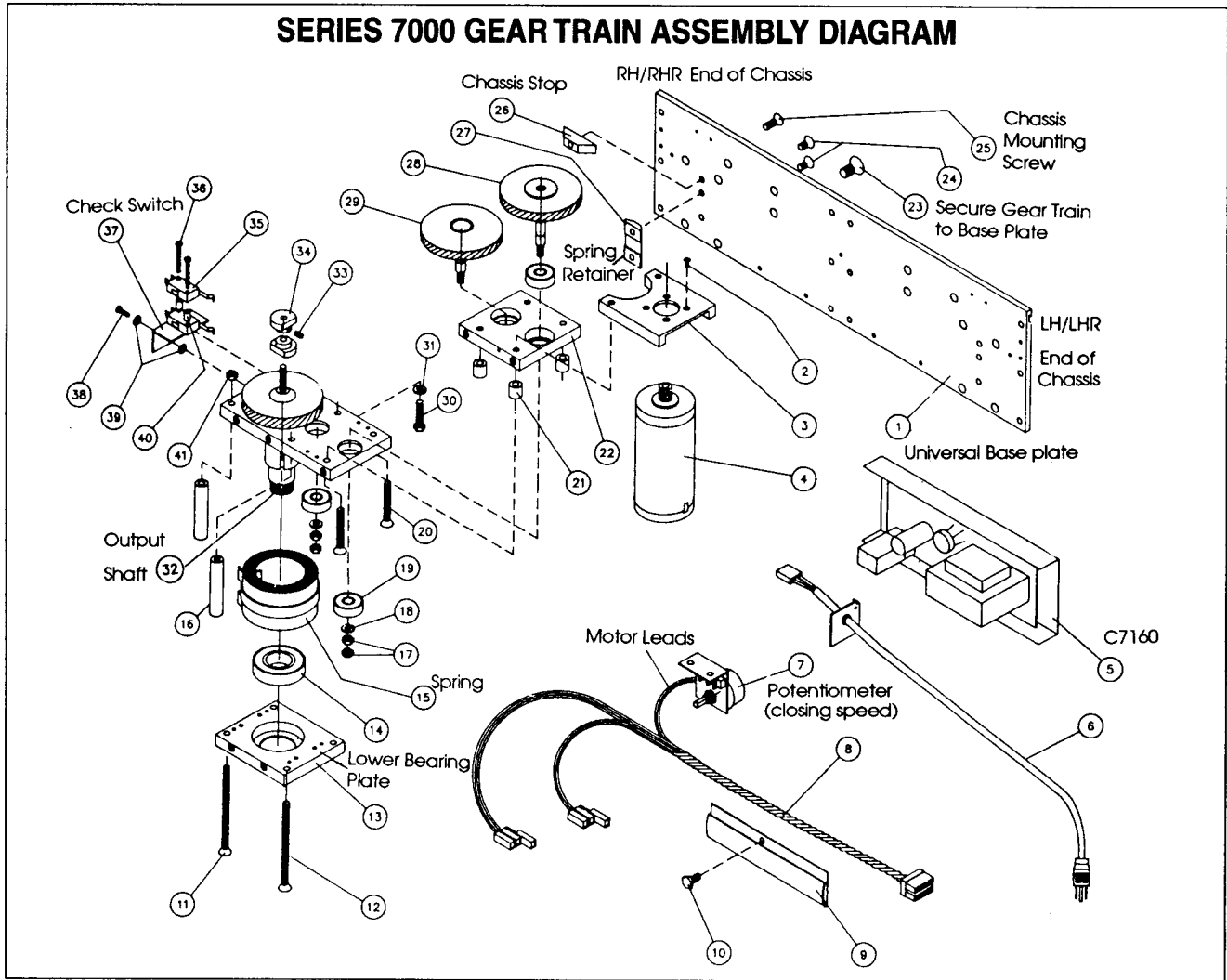

C7100-2 Series 7000 Gear Train Assembly

1	C7012-2	OPERATOR BASE PLATE	1	22	C7130-1	UPPER BEARING PLATE	1
2	C2187	SCREW 6-32 X 3/8" FHMS	4	23	C7089	BOLT 5/16-18 X 1/2" FHSCS	7
3	C7117	MOTOR MOUNTING BRACKET	1	24	C850A	BOLT 1/4-20 X 1/2" FHMS	2
4	C7115-1	MOTOR ASSEMBLY	1	25	C879R	BOLT 1/4-20 X 3/4" FHSCS	1
5	C7160-3	OPERATOR CONTROL	1	26	C7037	STOP CHASSIS MOUNT	1
6	C7150	POWER CORD ASSEMBLY	1	27	C4028	SPRING RETAINER BRACKET	1
7	C4165	POTENTIOMETER (PART OF C9156)	1	28	C7111	1ST TRANSFER SHAFT ASSY	1
8	C9156	OPERATOR WIRING HARNESS	1	29	C7113-2	2ND TRANSFER SHAFT ASSY	1
9	C7083-1	WIRE GUIDE	1	30	C576	BOLT 1/4-20 X 1 1/2" HHMS	1
10	C4056	BOLT 5/16-18 X 1/2" HHMS	1	31	C483	LOCK WASHER 1/4" SPLIT	1
11	C7078	BOLT 1/4-20 X 4" FHMS	1	32	C7020-4	OUTPUT SHAFT ASSEMBLY	1
12	C7079	BOLT 1/4-20 X 4 1/2" FHMS	1	33	C5192	BOLT 10-24 X 3/16" SSS	2
13	C7132	LOWER BEARING PLATE	1	34	C7024-1	CHECK SWITCH CAM	2
14	C7063	BEARING 1"ID X 2"OD	1	35	C2106	MICROSWITCH	2
15	C7050	CLOSING SPRING #D	1	36	C7081	SCREW 4-40 X 1-1/4" BHMS	2
16	C7043-1	SPACER 1/2" OD X 2 1/2"	2	37	C7027	SWITCH MOUNTING BRACKET	1
17	C7044	NUT 1/4-28 HEX LOCK	4	38	C410	BOLT 8-32 X 1/2" HHMS	2
18	C7036	WASHER - SHAFT RETAINER	2	39	C7058	WASHER #8 BRASS	4
19	C4061	BEARING 3/8"ID X 1 1/8"OD	3	40	C8201	SPACER 1/4"OD X 5/16"	2
20	C7066-1	BOLT 1/4-20 X 1 3/4" FHMS	2	41	C404	NUT 1/4-20 HEX	1
21	C7029-1	SPACER 1/2" OD X 1/2"	4				

Owner/Installer

We are pleased that you have chosen Horton Automatics EasyAccess™ Swing Door Operator.

Horton Automatics carefully designed, tested and built the operator to give the highest quality performance within its limits.

The operator will offer many years of dependable, safe service provided it is properly installed, adjusted and maintained according to the instructions herein.

This manual is intended to assist the installer with the installation and adjustments of the operator and to serve as a guide for the owner so he can make regular inspections to keep it in good working order.

Horton Automatics Series 7000 Operator is offered with several options. This manual includes most of them. Should you have special requirements, seek assistance from the Horton Automatics factory.

SERVICE AVAILABILITY

Horton Automatics products are distributed through a nationwide network of independently owned companies that offer both installation and service.

For the Horton Automatics distributor in your area, call (800) 531-3111 in the U.S. and 361-888-5591 outside U.S. or consult the yellow pages under "Door-Operating Devices."

LIMITED WARRANTY

Horton Automatics (Seller) warrants to the Buyer all products they manufacture to be free from defects in material and workmanship, under normal use and service, for twelve months from the date product is placed in operation. The Seller's obligation under this warranty is limited to repair or replacement at the factory, any parts which shall be returned to the Seller with transportation charges prepaid and which after examination, shall disclose to its satisfaction to be defective. Said warranty shall not apply to such products which shall have been installed, altered, or repaired by any person not expressly authorized in writing for such purpose by the Seller, or subjected to misuse, negligence or accident. The aforesaid warranty is made expressly in lieu of other warranties, expressed or implied and in lieu of any other obligations or liabilities on the part of the Seller and the Seller neither assumes nor authorizes any person to assume for it any other liability or obligations in connection with the sale of such products to the Buyer.

There is no warranty of merchantability or fitness for any particular purpose, nor is there any warranty, expressed or implied, except as specifically stated above. Seller shall not be liable for special or consequential damages, nor for claims of any third party against the buyer.

Generally, the installing distributor provides a one-year warranty covering the labor and transportation charges for defective parts replacement. Please ask your installing distributor for any warranty concerning these items. Any such warranty is only from and on behalf of such distributor, as Seller does not authorize any other party to provide any other warranty on behalf of Seller.



4242 Baldwin Blvd.
Corpus Christi, Texas 78405-3399
361-888-5591
Fax: 361-888-6510
Toll Free in North America:
800-531-3111
Fax: 1-800-531-3108

Horton Automatics, Ltd.
Unit A, Hortonwood 31
Telford, Shropshire
England TF1-4GS
++44 1952 670169
Fax: ++44 1952 670181