

"A" Series

10. ELECTRICAL WIRING

When the operator is delivered from the factory, it is only necessary to connect the 115 VAC and the external impulse devices. (See figure 10)

When connecting the 115 VAC, be sure to connect the hot leg (black wire) to connection No. 2. If the black and the white wire are interchanged, the printed circuit board will not be protected by the fuse. If a four way switch is to be installed, the jumpers between terminals No.11, 12, and 13 must be removed.

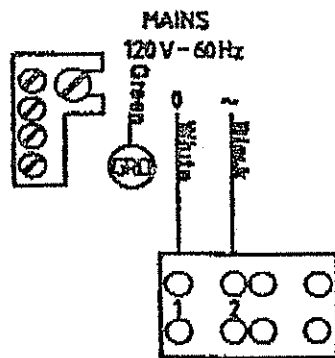
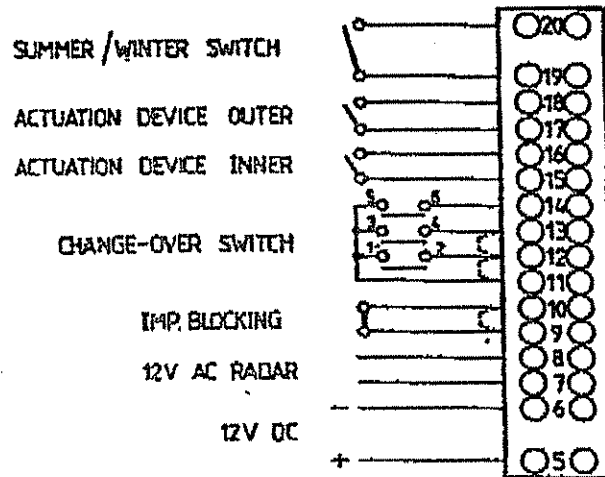

FIG. 10