

## Technical Data Sheet

ASSA ABLOY, the global leader  
in door opening solutions

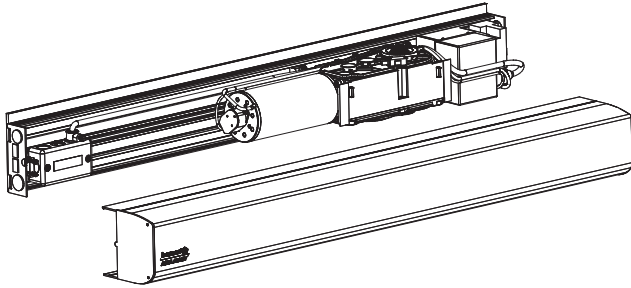

### SW200i Swing Door Operator

The Besam SW200i is the definitive pedestrian swing door operator, performing to the highest standards in the industry. Packed with the most innovative and advanced technological features, the Besam SW200i performs in the most adverse conditions and environments, setting a new level of performance for power door operators.

### Intended Use

The Besam SW200i is an automatic swing door operator suitable for use in exterior or interior entryways and corridors. The Besam SW200i is a universal heavy duty (HD) electro-mechanical operator suitable for use on large heavy doors, yet can also be used in low energy (LE) applications. The product can be either surface mounted or overhead concealed, on either side of the door, for pull or push applications. It is suitable for single doors, double doors and double egress doors fitted with swing clear hinges, offset pivots or center pivots. The operator is connected to the door leaf with a range of different arm systems.

Besam SW200i is designed to offer continuous use, a high degree of safety and maximum performance over the lifetime of your entrance. The Besam SW200i ensures all-around safety and can be equipped with a full range of sensor products providing swing door safety that meets or exceeds ANSI A156.10 standard.

### Operator Features and Performance

- Operator: electro-mechanical, non-handed operator, 24 volt,  $\frac{5}{16}$  hp motor
- ANSI Compliance: Field selectable full pedestrian usage (ANSI A156.10) and low energy (ANSI A156.19)
- Door Weight: up to 700 pounds (315 kg) per operator
- Door Size: up to 48" (consult for wider sizes)
- Manual Push Force: adjustable from 5 lbf – 15 lbf
- Hold Open Time: adjustable from 1.5 seconds to 30 seconds
- Wind Force Dampening: operator mechanically counteracts to wind forces, slowing down the opening or closing of the door
- Stack Pressure Compensation: operator counteracts to positive stack pressures, negative stack pressures, and sudden changes of stack pressures to maintain consistent door speeds
- Intelligent Trajectory Control: operator knows where the door should be at all times and adjusts torque accordingly. Dynamic braking helps cushion the door during opening to prevent going past 90 degrees, or during closing to prevent slamming.



- Extended Closing Torque (ECT): Besam's exclusive Extended Closing Torque (ECT) functionality provides extra torque in the last 10 degrees of closing, if needed, to close and latch the door. Speed remains constant so the door stays within ANSI standards.
- Latch Retry: if the door does not latch when closing, the SW200i will detect this condition and immediately open the door to 10 degrees and execute two attempts to latch the door.
- On-board timing sequencer
- On-board 12V or 24V transformer
- Low pass filter (i.e. "delay on make")
- Door position relay
- Kill input to close doors immediately
- Self-learning set-up – measures inertia and door weight
- Low Power Consumption (300 watts, 2.5 amp (max))

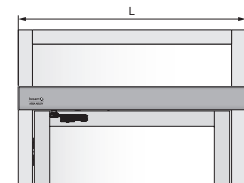

#### Door Set-ups:

Left: Single

Below Left: Simultaneous Pair

Below Right: Pair Egress

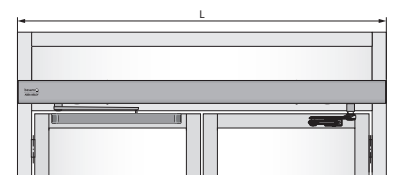
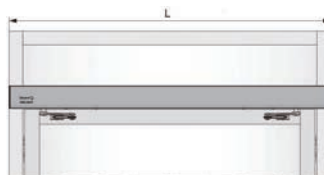

## Operation

- Automatic sensor activation (ANSI A156.10)
- Push plate activation (ANSI A156.19 or A156.10)
- Push and go feature allowing door to open automatically when operator senses movement of door (ANSI A156.19)
- Power assist open – provides easy to open push forces (ANSI A156.19)
- Internal, push to open, push to close (i.e., ratchet relay) (ANSI A156.19)
- Speed controlled Extended Closing Torque (ECT) to provide power assist close with on-board functionality to automatically adjust torque without increasing speed
- Loss of Power: the operator controls the door closing, preventing slamming of door
- Torque Limiting: if positive air pressure condition is removed, operator compensates accordingly and will not slam

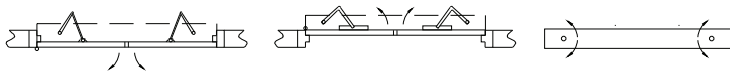

Door Operator Handings

## Electric Lock Management

- Lock monitoring prevents operator(s) from opening door(s) until release of electrified lock
- Operator pulls door closed before opening, unjamming electric latch hardware
- Sequenced operation between operators for pairs of doors allowing lock release and astragal coordination
- Electric Lock Output: selectable 12 VDC, maximum 1200 mA / 24 VDC, maximum 600 mA

## Sensor Monitoring

- Monitored Door Mounted Presence Sensors – upon detection of sensor failure, the operator will automatically revert to low energy mode
- Blanking Potentiometer: tells sensors on swing side of door when to shut off
- Sensor Recognition – learn process
- Torque Cancellation – Extended Closing Torque (ECT) is deactivated if signal is received from door mounted presence sensors of a possible obstruction

## Aesthetics

- Aesthetically pleasing, low profile appearance: 4-5/16" (109mm) high by 5-1/8" (130mm) deep
- Continuous header for full width of door
- Same header/housing as Besam PowerSwing and Besam SW100 for consistent sightlines in your facility
- Finishes: anodized, powder coat, Kynar, clad

## Configurations

- Surface Applied
- Overhead Concealed – center pivoted or offset pivoted doors
- Overhead Concealed – with emergency breakaway

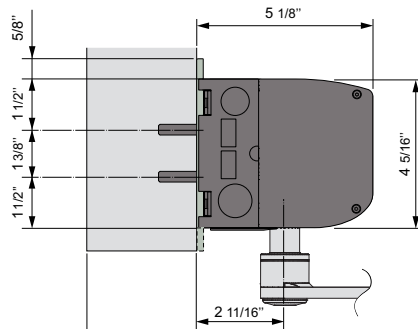

## Authorities

- UL/CUL approved
- UL Listed Fire Door Operator
- UL10C, UL325, UL991, UL244A, UL1998, UL1310
- IBC and CBC
- ANSI A156.10 / ANSI A156.19
- CAN/CSA-C22.2 NO 223-M91 and CAN/CSA-C22.2 NO 223-M92

## Sensor Packages

- Sensor Packages as follows:

### ANSI A156.19

- Activation: push plates per your selection
- Safety devices: not required per ANSI. Optional door mounted presence sensors (DMPS) are available

### ANSI A156.10

- Activation: push plates per your selection (motion sensors or push plates)
- Choice of Besam i-Adapt™ door mounted presence sensor system:
  - A202 – Besam i-Adapt Premium – stand alone, adapted field, door mounted presence sensors (DMPS)
  - A102– Besam i-Adapt Flex – overhead presence sensor (OPS) and two door mounted presence sensors (DMPS) per leaf (approach and safety)
  - A101 – Besam i-Adapt Flex - overhead presence sensor (OPS) and one door mounted presence sensors (DMPS) per leaf (safety)
  - A100 – Besam i-Adapt Flex – Knowing Act applications – pair egress only – motion sensor approach and safety side for secondary activation per ANSI A156.10

## Technical Specifications

<b>Operator type</b>	Electro-mechanical
<b>Door width</b>	36" – 48" (914 – 1219mm)
<b>Door weight</b>	100 – 700 lb (45 – 315 kg)
<b>Power supply</b>	120 V AC +10/-15%, 50/60 hz
<b>Power consumption</b>	Max. 300W
<b>Auxiliary voltage</b>	24 V DC, max. 700 mA
<b>Internal control fuse</b>	2 x T 6, 3 AH 250 V
<b>Electro-mechanical locking device</b>	Selectable: 12V DC, max. 1200 mA / 24 V DC, max. 600 mA
<b>Door opening</b>	<b>Push:</b> 80 – 110° with reveal 0 – 12" (0 – 305mm) <b>Pull:</b> 80 – 110° with reveal 0 – 5-1/8" (0 – 130mm) <b>PAS:</b> 80 – 95° (concealed application)
<b>Opening time (0 – 80°)</b>	Variable between 2 – 12 seconds
<b>Closing time (90 – 100°)</b>	Variable between 4 – 12 seconds
<b>Hold open time</b>	1,5-30 seconds
<b>Ambient temperature</b>	-31° F to 160° F (-35° C to 71° C)
<b>Relative humidity</b>	Max. 85%
<b>Drive weight unit (non-condensing)</b>	19.8 lb (9 kg)
This product is to be installed internally or externally with suitable weather protection.	
<b>Class of protection</b>	IP 20.
<b>Complies with:</b> ANSI/BHMA A156.19, ANSI/BHMA A156.10, UL325, UL 991, UL 244A, UL 1998, UL 1310, UL 10C, CAN/CSA-C22.2 NO 223-M91, CAN/CSA-C22.2 NO 247-92 and CA State Fire Marshall	