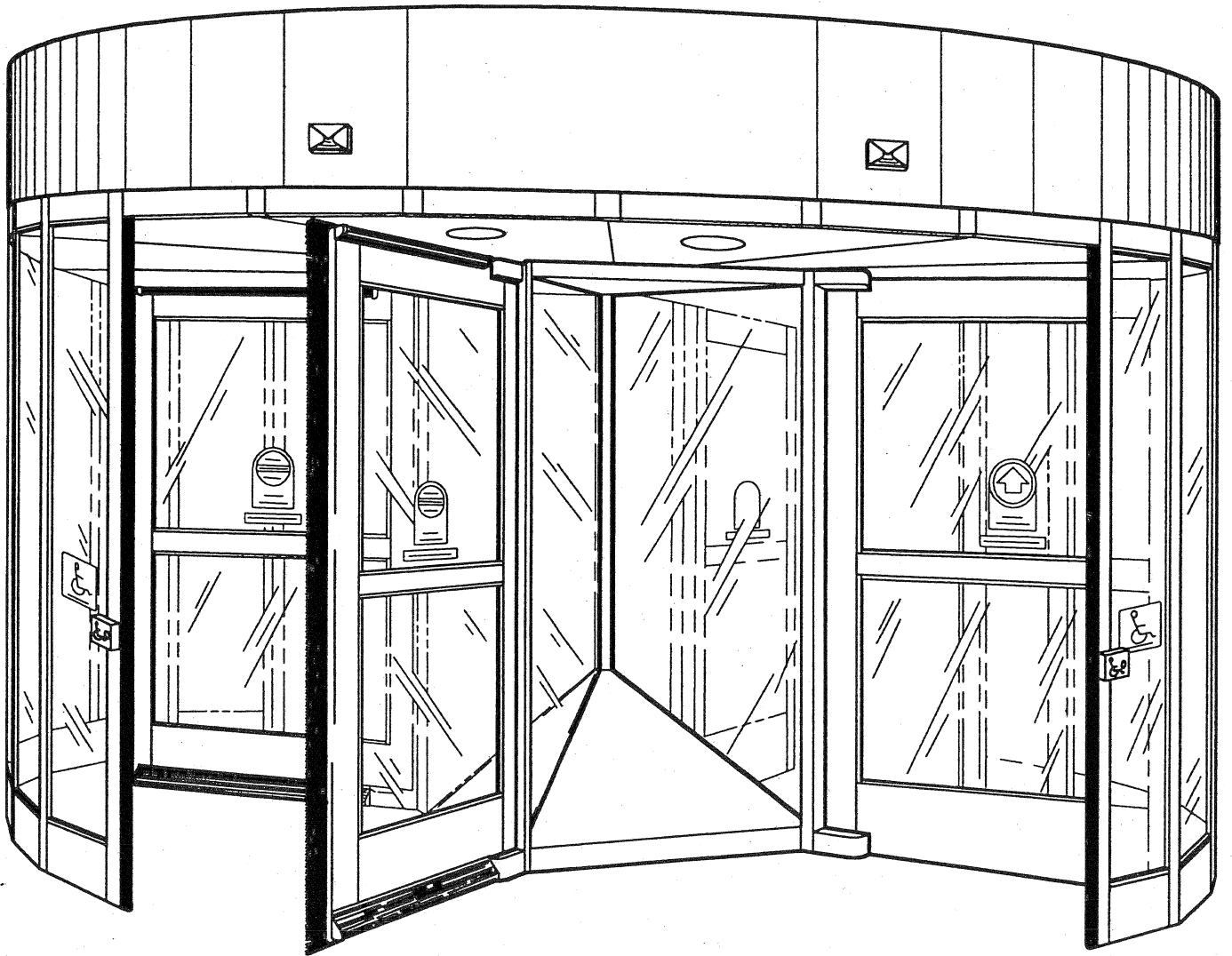


# Series 9600

## Grand™ Revolving Door

### Segmented and Round Drum



**Owner's Information**  
**General Information**  
**Installation Instructions**  
**Adjustments**

G960, 11-90  
Revised 9-96

  
**Horton**  
AUTOMATICS

## TABLE of CONTENTS

1. OWNER'S INFORMATION .....	G960.3
2. SERVICE AVAILABILTY .....	G960.3
3. LIMITED WARRANTY .....	G960.3
4. INFORMATION TO BE PROVIDED BY THE DISTRIBUTOR TO THE OWNER .....	G960.4
5. GENERAL INFORMATION .....	G960.4
6. ITEMS TO CHECK PRIOR TO INSTALLATION .....	G960.4
7. TOOL LIST .....	G960.4
8. FIND EXACT LOCATION OF DOOR .....	G960.5
9. SEGMENTED DRUM ASSEMBLY .....	G960.7
10. JOINING DRUM HALVES .....	G960.12
11. ROUND DRUM ASSEMBLY .....	G960.13
12. ROUND CANOPY ATTACHMENT .....	G960.14
13. INSTALLING GEAR TRAIN SUPPORT .....	G960.15
14. INSTALLING GEAR TRAIN .....	G960.16
15. INSTALLING BOTTOM BEARING .....	G960.19
16. INSTALLING CENTER SECTION .....	G960.19
17. C9373-1 COUPLING ASSEMBLY .....	G960.21
18. BRUSH ASSEMBLY .....	G960.22
19. INSTALLING CEILING SUPPORT .....	G960.23
20. INSTALLING CEILING PANELS .....	G960.23
21. INSTALLING WEATHER-STRIPPING AT CENTER SECTION .....	G960.24
22. INSTALLING REED SWITCHES .....	G960.26
23. INSTALLING DOOR PANELS .....	G960.27
24. INSTALLING MOTOR AND QUARTER POINT ACCESSORIES .....	G960.28
25. DOOR LOCKS AND STRIKES .....	G960.30
26. MICRO-SWITCH MOUNTING .....	G960.31
27. ELECTRICIAN'S WIRING INFORMATION .....	G960.31
28. GENERAL OPERATING INFORMATION .....	G960.32
29. WIRING MOTOR AND QUARTER POINT SWITCHES .....	G960.32
30. ADJUST SAFETY SENSITIVITY .....	G960.32
31. WIRING BREAKOUT SWITCHES .....	G960.33
32. WIRING LOCK MONITOR SWITCHES .....	G960.33
33. INSTALLING AND WIRING ON/OFF SWITCH .....	G960.34
34. INSTALLING HANDICAP BUTTON .....	G960.34
35. WIRING SAFETY NOSING .....	G960.35
36. INSTALLING AND WIRING MOTION DETECTORS .....	G960.35
37. ADJUSTING DOUBLE ACTING CLOSER .....	G960.36
38. INSTALLING SEGMENTED DRUM GLAZING .....	G960.37
39. INSTALL DOOR PANEL GLAZING .....	G960.37
40. CURVED GLASS INSTALLATION .....	G960.38
41. DECAL APPLICATION .....	G960.42
42. ELECTRICAL DIAGRAM - DRAWING 10000.3 .....	G960.43
43. ELECTRICAL DIAGRAM - DRAWING 10000.2 .....	G960.45
44. ELECTRICAL DIAGRAM - DRAWING 10000.1 .....	G960.47

## TABLE of FIGURES

1. EQUAL ARC METHOD .....	G960.5
2. REVOLVING DOOR LAYOUT.....	G960.5
3. DRUM ASSEMBLY (SEGMENTED CANOPY) .....	G960.6
4. DRUM ASSEMBLY (ROUND CANOPY) .....	G960.6
5. PLACEMENT of EXTRUSIONS (SEGMENTED CANOPY) .....	G960.7
6. PLACEMENT of EXTRUSIONS (ROUND CANOPY).....	G960.7
7. ORIENTATION OF DRUM HALVES .....	G960.8
8. CENTER CANOPY SECTION ASSEMBLY (SEGMENTED DRUM) .....	G960.9
9. CENTER CANOPY SECTION ASSEMBLY (ROUND CANOPY) .....	G960.9
10. JOINING DRUM HALVES (SEGMENTED CANOPY) .....	G960.10
11. JOINING DRUM HALVES (ROUND CANOPY) .....	G960.10
12. JOINING ROUND CANOPY SECTIONS .....	G960.11
13. LEVELING DRUM .....	G960.12
14. ANCHORS .....	G960.12
15. BOTTOM DRUM RAIL ASSEMBLY .....	G960.13
16. VERTICAL RAIL ASSEMBLY .....	G960.13
17. ROUND DRUM ANCHORAGE .....	G960.13
18. GEAR TRAIN SUPPORT BRACKET INSTALLATION (ROUND CANOPY) .....	G960.14
19. ROUND DRUM ORIENTATION .....	G960.14
20. ROUND REVOLVING DOOR CANOPY .....	G960.15
21. GEAR TRAIN SUPPORT (SEGMENTED CANOPY) .....	G960.16
22. GEAR TRAIN SUPPORT (ROUND CANOPY) .....	G960.17
23. MOUNT GEAR TRAIN .....	G960.18
24. PLUMB VERTICAL RAILS .....	G960.18
25. GEAR TRAIN ALIGNMENT .....	G960.18
26. BOTTOM BEARING .....	G960.19
27. STUB SHAFT INSTALLATION .....	G960.19
28. BOTTOM BEARING .....	G960.20
29. CEILING BRACE .....	G960.20
30. CENTER SECTION ATTACHMENT .....	G960.20
31. C9373-1 COUPLING ASSEMBLY .....	G960.21
32. COUPLING .....	G960.22
33. BRUSH ASSEMBLY .....	G960.22
34. CEILING SUPPORTS .....	G960.22
35. CEILING PANEL LOCATIONS .....	G960.23
36. CEILING PANEL INSTALLATION .....	G960.24
37. WEATHER STRIP INSTALLATION .....	G960.25
38. ACCESS PANEL FOR CLEAR CORE .....	G960.26
39. ACCESS PANEL FOR DISPLAY CORE .....	G960.26
40. REED SWITCH INSTALLATION .....	G960.27
41. DOOR PANELS .....	G960.27

## TABLE of FIGURES

42. MOTOR AND QUARTER POINT INDICATOR .....	G960.28
43. VISTASTOP INSTALLATION .....	G960.29
44. DOOR LOCKS .....	G960.30
45. SURFACE LOCKS AND MICROSWITCH .....	G960.31
46. WIRING SWITCHES .....	G960.33
47. ELEVATION OF 4-WING GRAND REVOLVING DOOR .....	G960.34
48. C9616 HANDICAP SWITCH .....	G960.35
49. DETECTION PATTERN .....	G960.36
50. DOOR CLOSER ADJUSTMENTS .....	G960.36
51. SEGMENTED DRUM SECTION .....	G960.37
52. DOOR PANEL SECTION .....	G960.37
53. FLOOR PLAN OF 4-WING ROUND GRAND REVOLVING DOOR .....	G960.38
54. HORIZONTAL SECTION AT THROAT RAIL .....	G960.38
55. INNER BOTTOM RAIL .....	G960.38
56. BOTTOM VIEW OF ENCLOSURE WALL .....	G960.39
57. PARTIAL PLAN VIEWS .....	G960.39
58. VERTICAL SECTION .....	G960.40
59. BOTTOM VIEW OF ENCLOSURE WALL .....	G960.40
60. VERTICAL SECTIONS .....	G960.41
61. DECALS .....	G960.42
62. ELECTRICAL DIAGRAM - DRAWING 10000.3 .....	G960.43
63. VISTASTOP COMPONENTS .....	G960.44
64. ELECTRICAL DIAGRAM - DRAWING 10000.2 .....	G960.45
65. RETROFIT SUPERSCAN COMPONENTS .....	G960.46
66. ELECTRICAL DIAGRAM - DRAWING 10000.1 .....	G960.47



## **INSTALLATION INSTRUCTIONS FOR THE GRAND REVOLVING DOOR SERIES 9600**

### **1. OWNER'S INFORMATION**

We are pleased that you have chosen a Grand Revolving Door from Horton Automatics. This door system will provide many years of safe automatic operation while conserving energy provided the unit is properly installed and maintained.

#### **This Manual is Intended to Serve Two Purposes:**

- A. To assist the Horton Distributor (Installer) in the installation / adjustment of a Grand Revolving Door.
- B. To serve as a guide for the Owner to become familiar with the operation and safety of his Grand Revolving Door Unit.

**Regular inspections are required to keep each door in safe and proper working order. Please acquaint yourself with and follow all instructions in this manual.**

Horton Automatics Grand Revolving Doors are offered with many options. Consequently, it is possible that this manual may not address all of the possibilities. This Manual, Wiring Diagrams, and Individual Shop Drawings should be kept in your files.

### **2. SERVICE AVAILABILITY**

Horton Automatics' products are manufactured at the company's plant facilities in Corpus Christi, Texas and Telford, England. A Worldwide network of authorized independent distributors offer both installation and a maintenance program. For the local Horton Automatics distributor in your area call 1-800-531-3111 or 512-888-5591 (U.S. and Canada), or consult the Yellow Pages of your Telephone Book under "Door-Operating Devices." In Europe, call the Horton Plant in Telford, England at 011-44-1952-670169 or fax at 011-1952-670181.

### **3. LIMITED WARRANTY**

Horton Automatics (the "Seller") warrants to the Buyer all products manufactured by the Seller to be free from defects in material or workmanship under normal use and service. The Seller's obligation under this warranty is limited to repairing or replacing, at its factory, any parts which are returned to Seller within twelve months, freight charges prepaid, and which upon examination prove to be defective. Said warranty shall not apply to products which have been installed, altered, or repaired by any persons not expressly authorized by Seller in writing to do so, or which have been subjected to misuse, negligence or accident.

There is no warranty of merchantability of fitness for any particular purpose or any other warranty express or implied except as specifically stated herein.

Seller shall in no event be liable for special or consequential damages of Buyer or claims of any third party against Buyer.

Generally, the installing distributor provides a one-year warranty covering the labor and transportation charges for defective parts replacement. Please ask your installing distributor for any warranty concerning these items. Any such warranty is only from and on behalf of such distributor, as Seller does not authorize any other party to provide any other warranty on behalf of Seller.

#### 4. INFORMATION TO BE PROVIDED BY THE DISTRIBUTOR TO THE OWNER

- A. Location of cutoff switches.
- B. Instructions on circuit breaker locations
- C. Necessary warnings not covered in these general instructions.
- D. Daily Check List
- E. Phone number to call regarding problems or request for service. If a potentially hazardous situation is suspected, lock the doors until a professional inspection is made and the problem is corrected.

**The following information should be furnished by the Horton distributor to the owner.**

Date equipment shipped from Horton: \_\_\_\_\_

Date equipment placed into service: \_\_\_\_\_

Horton invoice and serial number for warranty reference: \_\_\_\_\_

Equipment type: \_\_\_\_\_

Control logic version: \_\_\_\_\_

Accessories included: \_\_\_\_\_

**See the product label located on the gear train support tubes next to the gear train or in the control enclosure box for work order number and serial number, power requirements, etc.**

#### 5. GENERAL INFORMATION

A revolving door installation is more involved and time consuming than most other types of doors. The floor area is larger and there is more parts to assemble. Skill must be used to assure that the door is placed properly. Holes must be drilled in the correct places and the door in its entirety must be plumb and level. Therefore the door must be installed under the supervision of a trained professional distributor. Revolving door sections are prefabricated and shop fitted to facilitate installation. Round canopies are fabricated in either four or six sections. Ceiling panels are custom cut and fit for each canopy. It is very important that installer begin installation at labeled starting points (A first, then B,C, etc...) and make attachments at labeled match points.

#### 6. ITEMS TO CHECK PRIOR TO INSTALLATION

- A. NOTE: Dimensions in ( ) are metric millimeter equivalents. Example - 1"(25)
- B. The floor area must be level inside the door. If not, notify the owner or general contractor immediately as the general safety and weatherstrip seals may be adversely affected +/- 1/2" (12) over the entire door.
- C. Check to see that the finished floor covering (tile, carpet) is in place or if there will be some other type of flooring to be added. Shimming of the door may be required if flooring is added later. Suggest to the owner that the threshold be clearly marked with mats or flooring pattern.
- D. The door requires a 120VAC 60 cycle 20 AMP dedicated circuit to supply power to the operator, lights and speed control.
- E. Check packing list to make sure all materials are accounted for. Check for damaged material.
- F. Review enclosed erection print, cut sheets, production documentation and related drawings. The wiring diagram can be found taped to the lid of the control box.
- G. Be familiar with all the desired functions of the door such as handicap switch attachment.

#### 7. TOOL LIST - For a fast complete installation the following tools will be required:

- |  |   |
|--|---|
| <input type="checkbox"/> Trammel points or beam compass        | <input type="checkbox"/> 12"(305) or 18" (457) long 3/8" (10) Masonry bit |
| <input type="checkbox"/> Hammer drill                          | <input type="checkbox"/> Plumb bob  |
| <input type="checkbox"/> 6'(1829) Spirit level                 | <input type="checkbox"/> 9/16" (15) deep well socket, ratchet & extension |
| <input type="checkbox"/> Isopropyl Alcohol                     | <input type="checkbox"/> Mobilux EP-2 lubricating grease or equal         |
| <input type="checkbox"/> Allen wrench set                      | <input type="checkbox"/> Black felt-tip marker                            |
| <input type="checkbox"/> 1/4"(6) dia. utility rope             | <input type="checkbox"/> Two saw-horses                                   |
| <input type="checkbox"/> Rubber mallet                         | <input type="checkbox"/> Transit level                                    |
| <input type="checkbox"/> Stubby straight or offset screwdriver | <input type="checkbox"/> Volt/ohm meter                                   |
|  | <input type="checkbox"/> Torque wrench - up to 300 in/lbs or 30 ft/lbs    |

## 8. FIND EXACT LOCATION OF DOOR

- A. Verify with general contractor and architectural drawings.
- B. Layout door as follows:
  - 1. Determine centerline location through the storefront, line A. (Figure 1)
  - 2. Determine centerline through the revolving door; use the Equal Arc Method to ensure squareness, line B.

**Follow this layout to determine wall post location dimensions. See erection print shipped with each door.**

### EQUAL ARC METHOD (Figure 1 & 2)

- 1. Measure 3'(991) on line A from each side of center point.
- 2. Draw 5'(1524) arc from these points on line A (top and bottom).
- C. Draw a circle from the center point representing the outside diameter of the door, line C. This will serve as a reference point for anchoring the wall section. Layout the revolver using the erection print. A black felt-tip marker should be used to prevent accidental erasure of layout lines. The outside edge of the wall post should touch this circle (Figure 2). The door location is now laid out and you should proceed to the assembly phase.

Figure 1 - Equal Arc Method

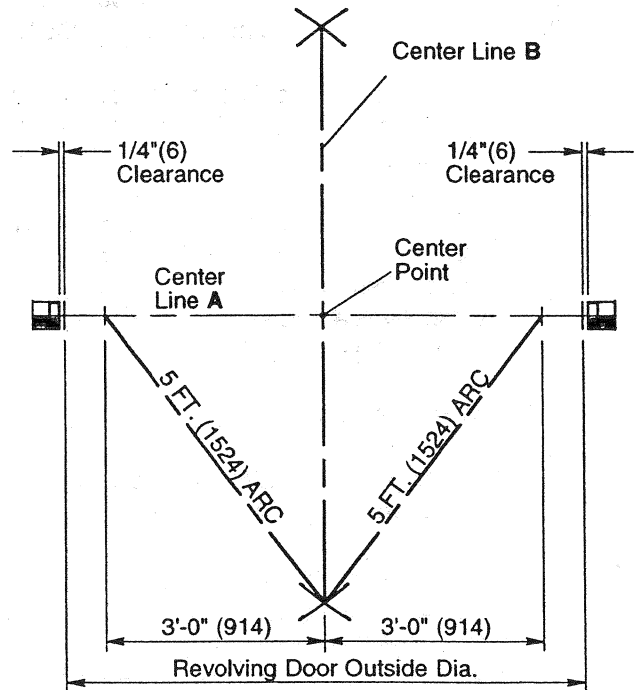


Figure 2 - Revolving Door Layout

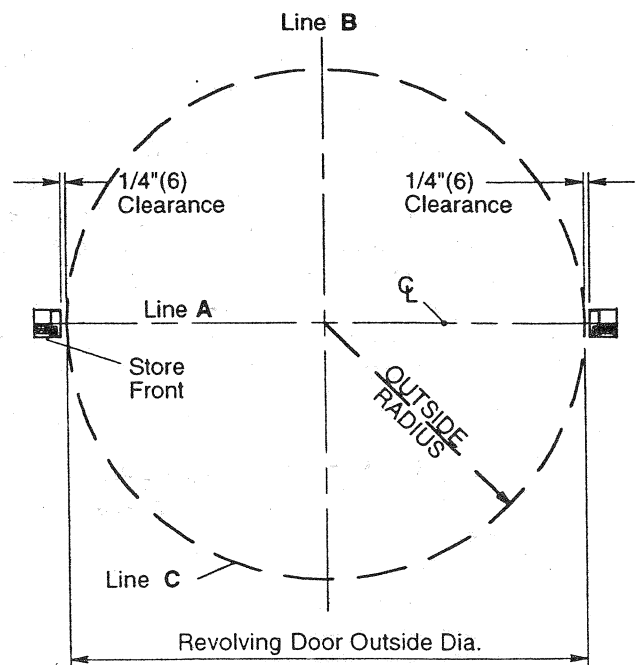
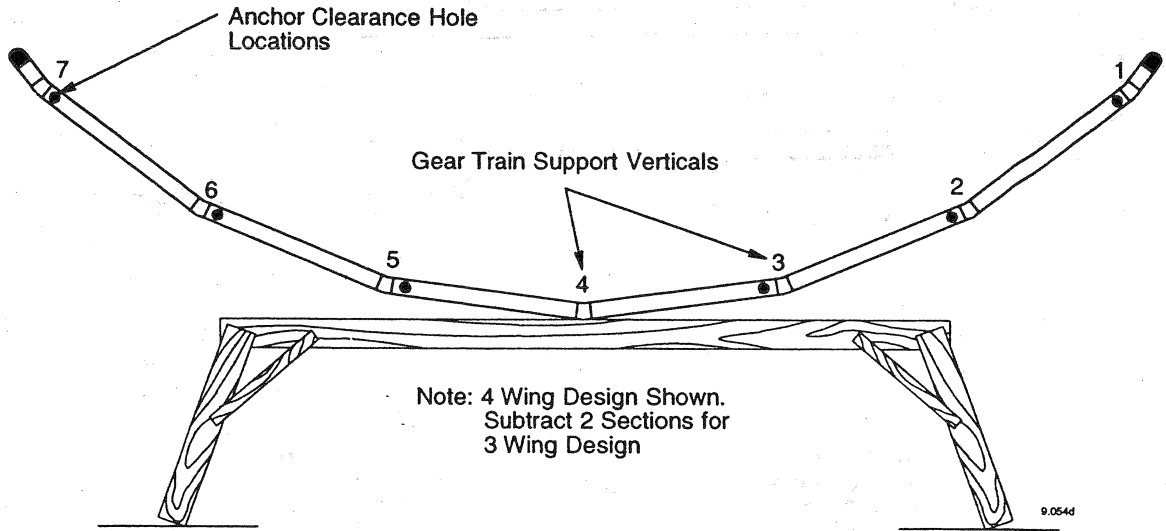


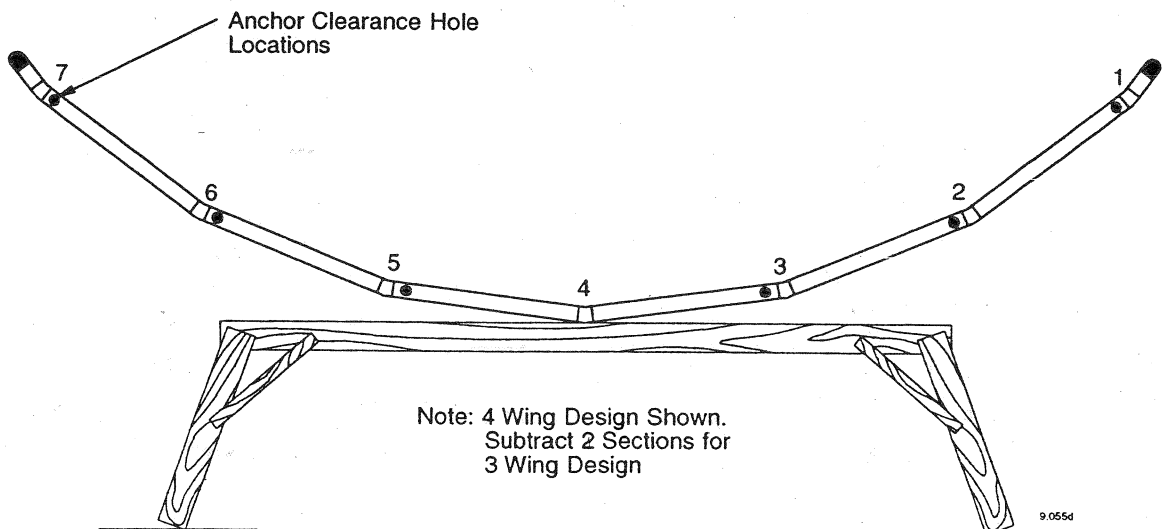
Figure 3 - Drum Assembly  
(Segmented Canopy)



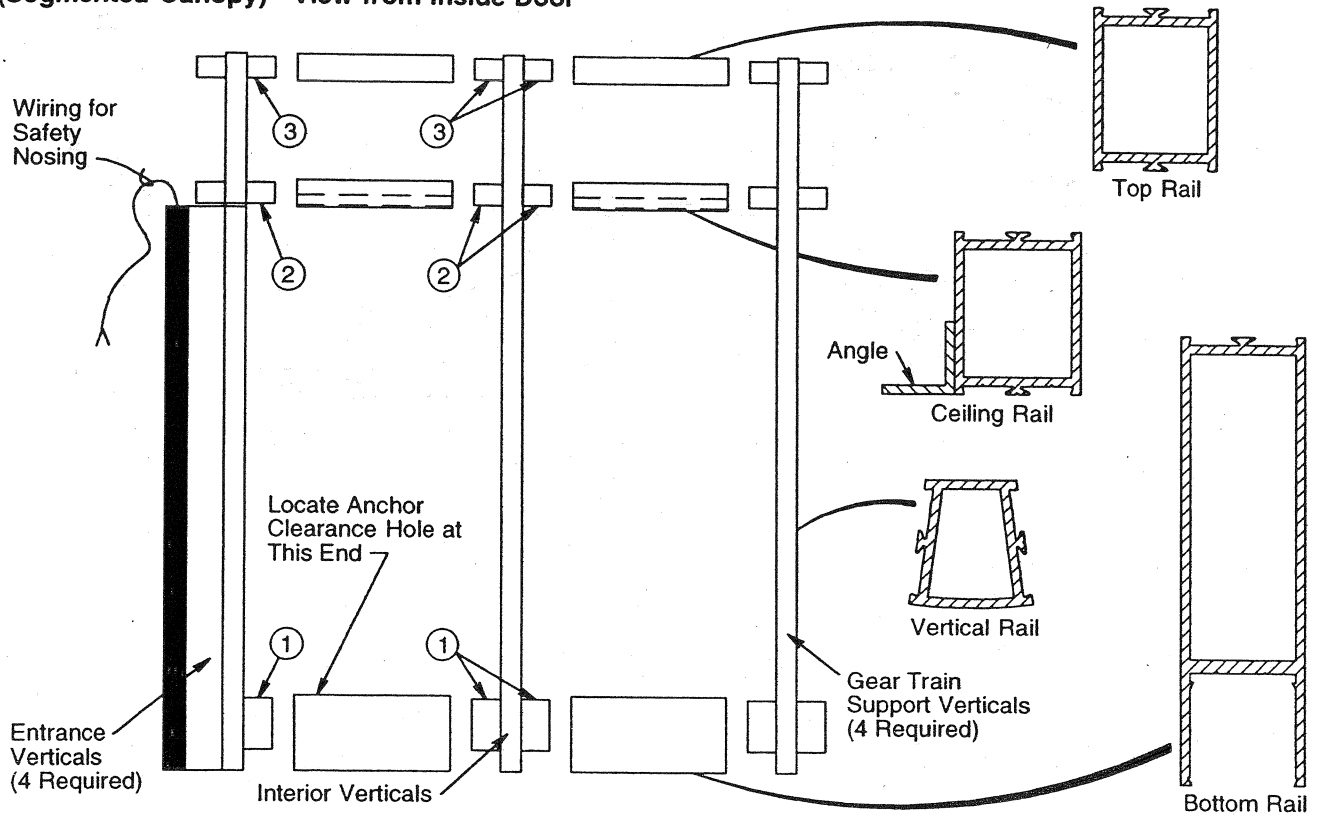
## 9. SEGMENTED DRUM ASSEMBLY

- A. Place all extrusions into groups to match all like parts. Lay out materials on provided packing or similar material to protect finishes. Orient the parts as to which are vertical (corner blocks installed) and horizontal members. Use labeled match points. Group the horizontal top rails, ceiling support rails with 1" (25) angle) and bottom rails together. These extrusions must be placed in the proper position in the drum assembly (Figure 5 & 6 - see match marks).

Figure 4 - Drum Assembly  
(Round Canopy)



**Figure 5 - Placement of Extrusions  
(Segmented Canopy) - View from Inside Door**



**Figure 6 - Placement of Extrusions  
(Round Canopy) - View from Inside Door**

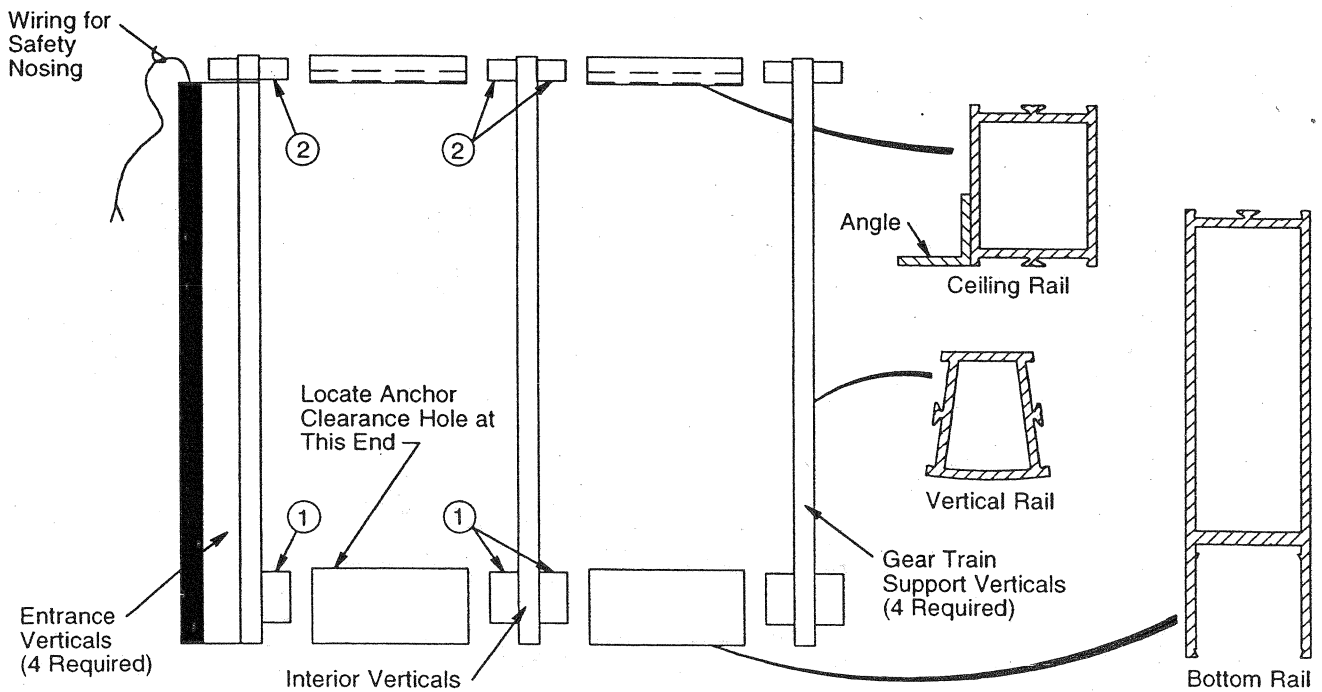
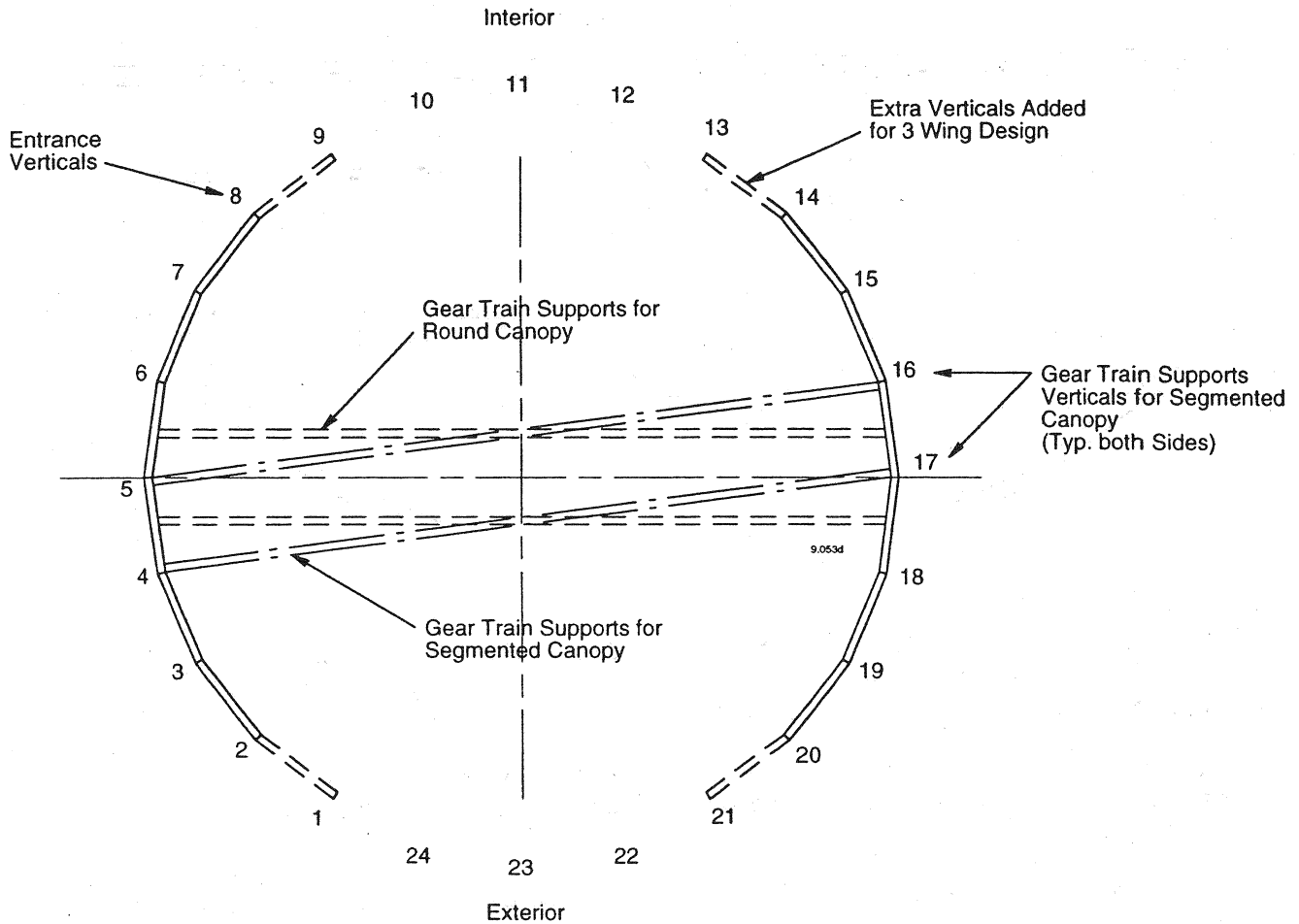


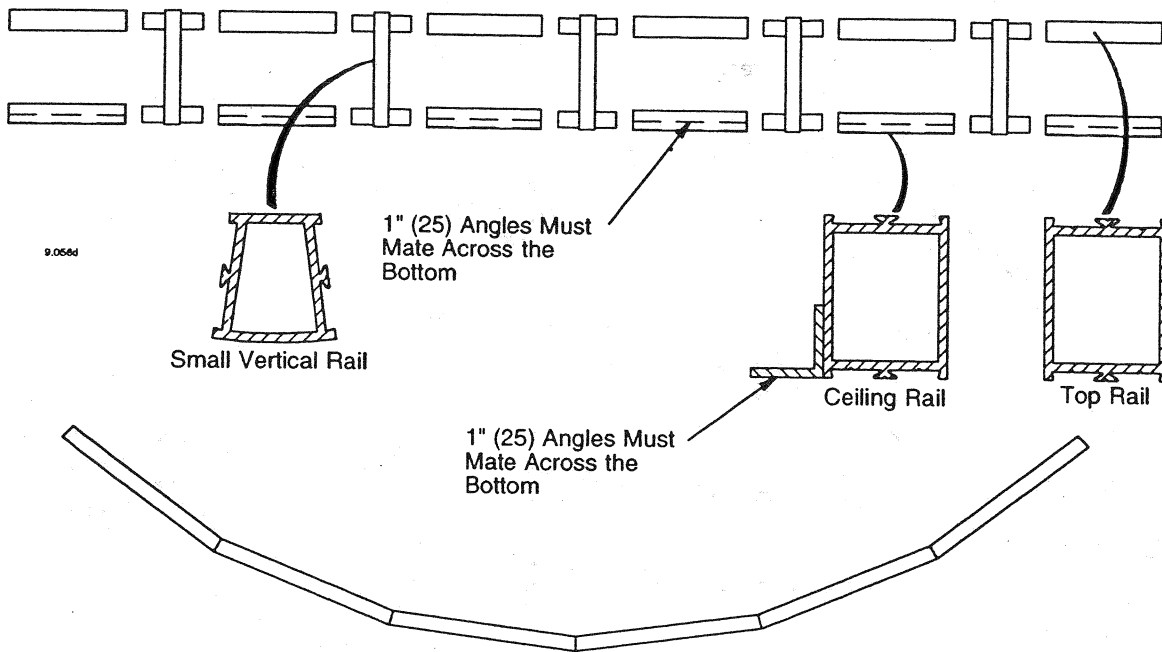
Figure 7 - Orientation of Drum Halves



- B. Starting with the vertical drum rails, place one entrance vertical rail on your left (labeled A,1) and one interior vertical rail on your right, across 2 saw-horses (Figures 3 & 4). Place one bottom horizontal rail on the corner block of the entrance vertical rail at point `1`. Make sure the anchor clearance hole is next to the entrance vertical rail (Figures 5 & 6). Place the ceiling support horizontal rail (The one with the 1" (25) angle attached to it) at point `2`. The short piece of 1" (25) angle on the vertical rails should line up with the 1" (25) angle on the ceiling support horizontal rail. If canopy is segmented, place one top rail at point `3` on the entrance vertical rail. Mate points 1, 2 & 3 (segmented canopy) or points 1 & 2 (round canopy - Figure 6) of the interior vertical rail to the horizontal rails on the entrance vertical. Secure drum sections first, then canopy sections with 10-24 x 3/4" flat head self tapping screws that are provided in the accessory pack.
- C. Add horizontal rails at point 1, 2 & 3 of the interior vertical rail. Add another interior vertical rail and mate 1, 2 (& 3) to the horizontals above. Tap joints with rubber mallet to completely close gaps. Secure with flat head screws as in previous step.
- D. Add the next two vertical rails which are the gear train support verticals and the associated horizontals.

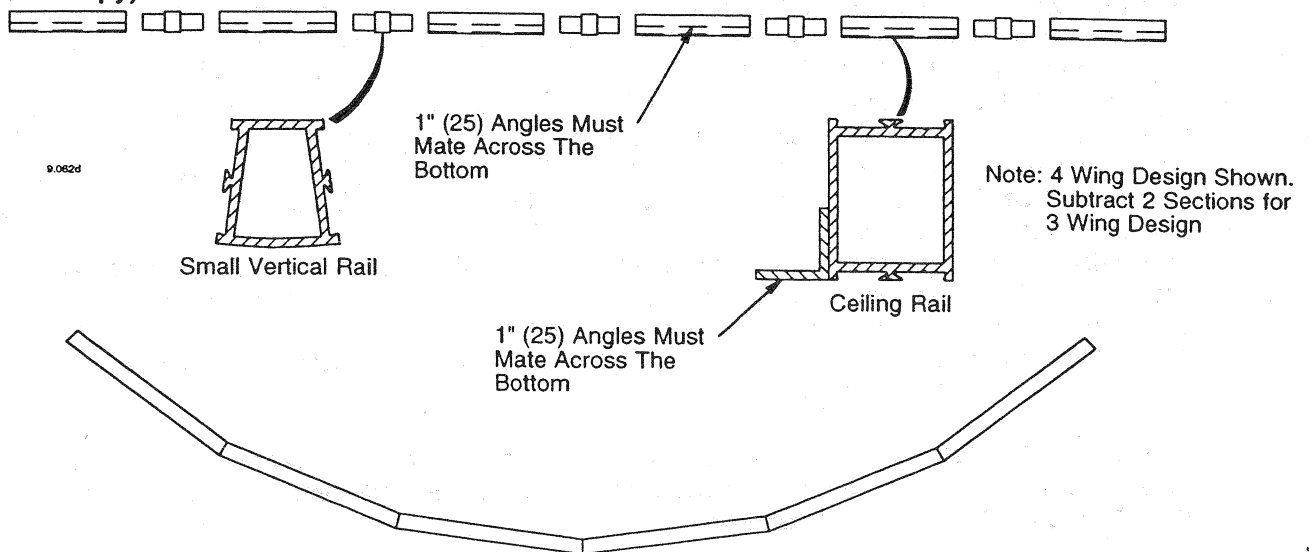
**PLEASE NOTE:** Gear train support verticals are the ones that have threaded holes in them between the ceiling and the top horizontal rails (Figures 3 & 5 segmented canopy only). (See Figures 4 & 6 for round canopy).

**Figure 8- Center Canopy Section Assembly  
(Segmented Canopy)**

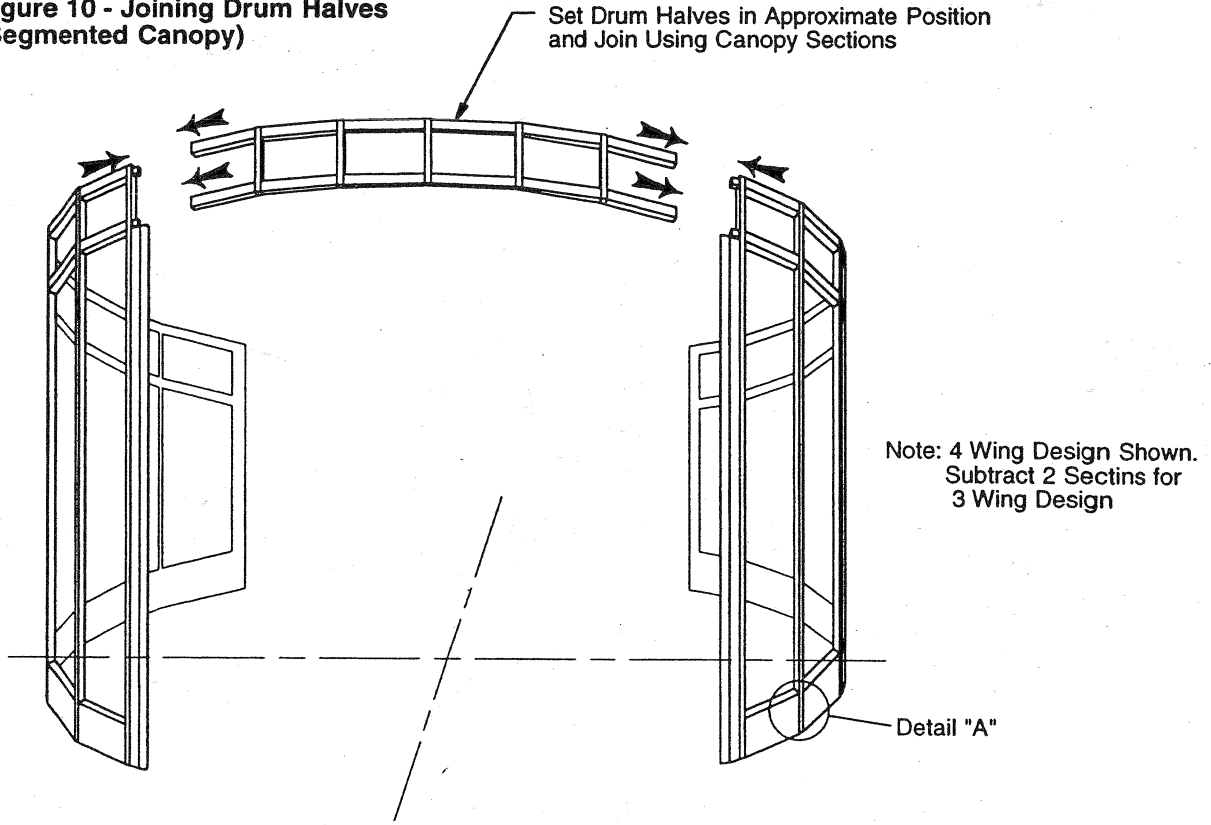


- E. Join remaining interior vertical rail and the associated horizontals followed by the entrance or throat vertical. Check the sequence with Figures 5,6, & 7 to make sure the gear train support verticals are in the proper place.
- F. Repeat the above steps for the opposite side of the drum. If you build both halves identically, as described, the gear train support plates end up opposite each other when the halves face each other as in plan (Figure 7).
- G. Assemble the center (throat) sections using the short vertical rails, ceiling rails & top rails on each side. If round canopy, the short vertical rails and top horizontal rails are not used. (Figures 8 & 9).

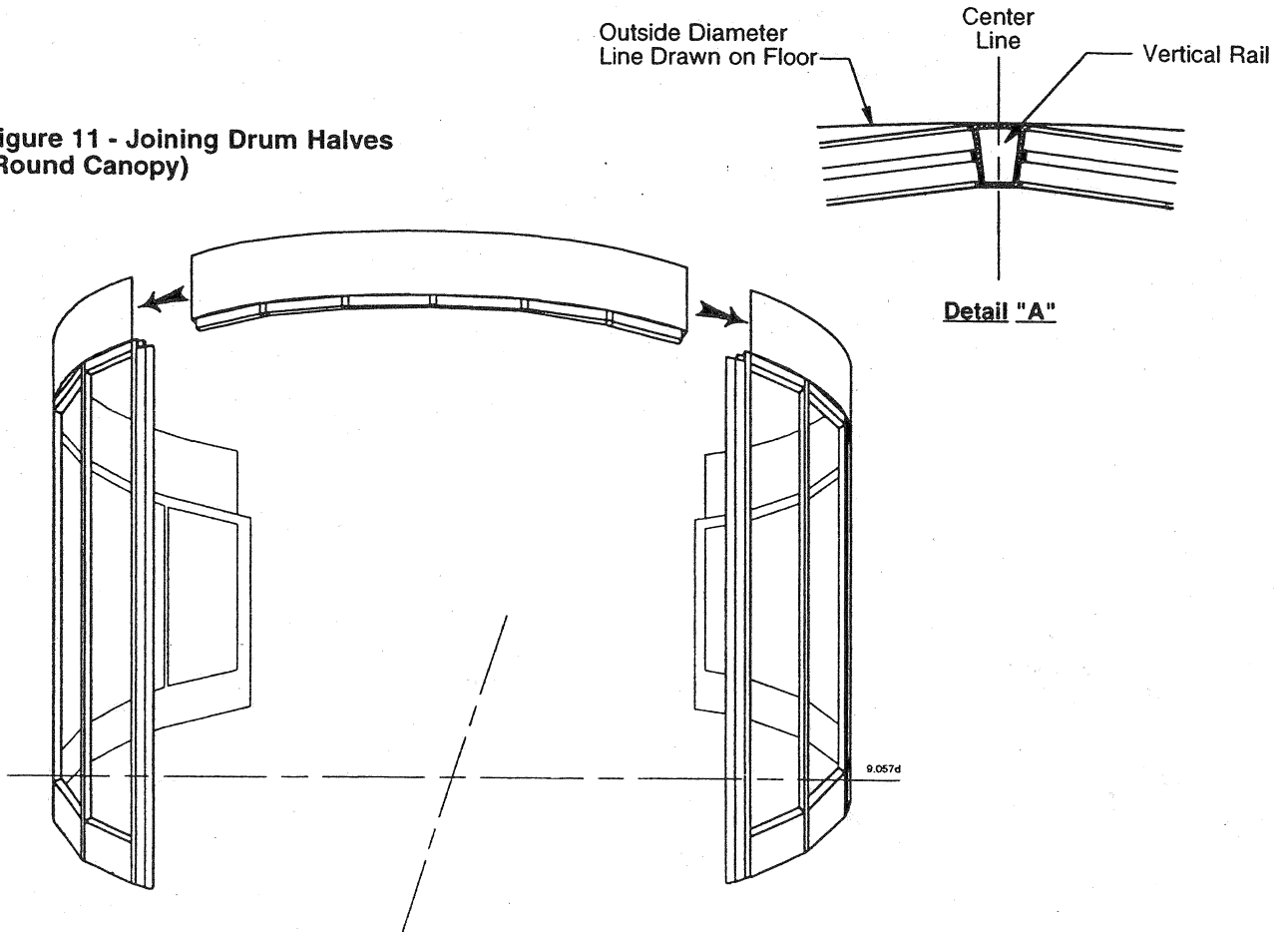
**Figure 9- Center Canopy Section Assembly  
(Round Canopy)**



**Figure 10 - Joining Drum Halves  
(Segmented Canopy)**



**Figure 11 - Joining Drum Halves  
(Round Canopy)**





G960.11  
4-96

Figure 12 - Joining Round Canopy Sections

Join Canopy Sections W/ C437  
#10-24 x 1/2" FHMS Through  
C1392 Roof Support Into Alum.  
Attachment Plate

Alum. Brace  
(10 Places or As  
Required) Secured to  
Canopy Section w/  
C565 #10 x  
3/8" PHMS

C565 #10x3/8"  
PHMS (Typ.)

Round Canopy Section

C2945 Extended Fascia

Pilot Hole

C9090 Curved Canopy  
Splice Plate Secured to  
Back Face of Canopy  
With Adhesive Cladding  
Tape

Curved Alum. Angle  
Attached to C2961  
Canopy Channel w/ #10 x  
3/8" PHMS

C337 Horizontal Rail

C2932 Vertical Rail

9.052d

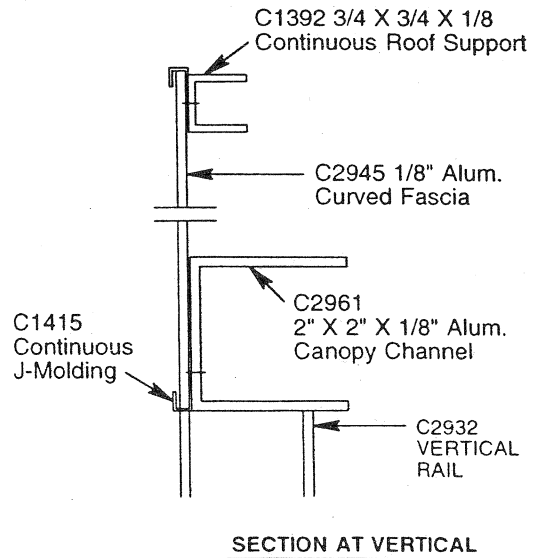
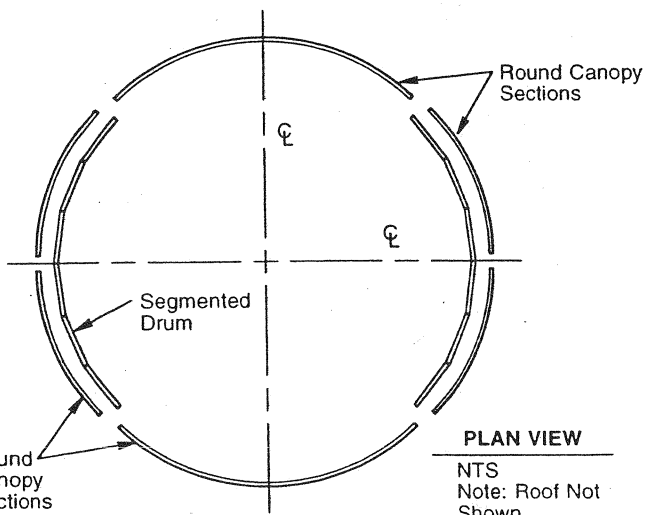
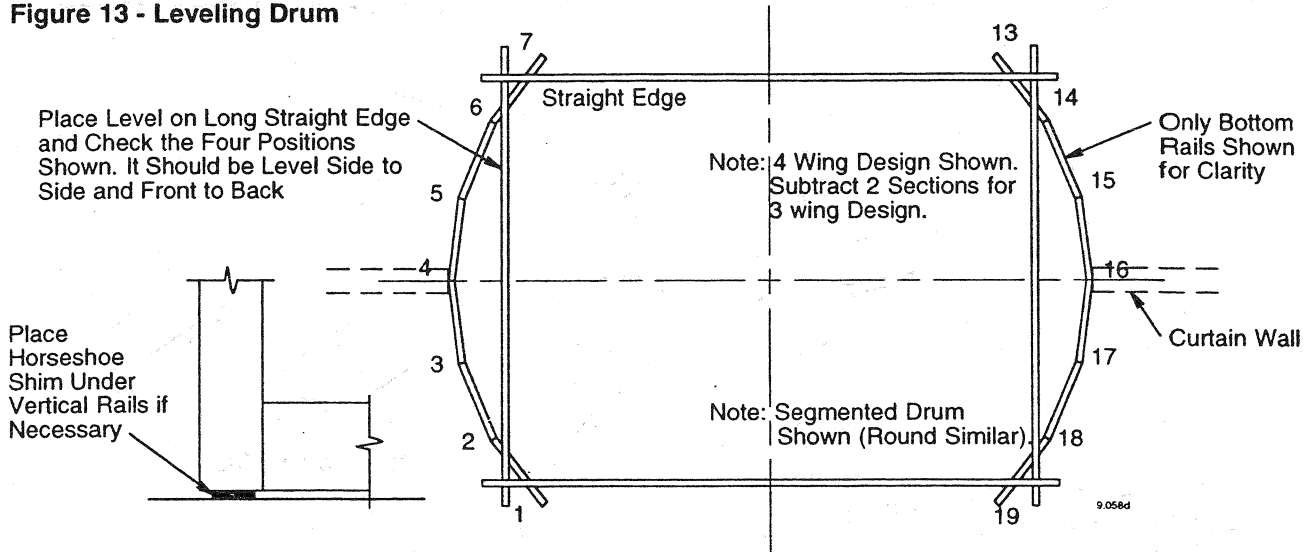


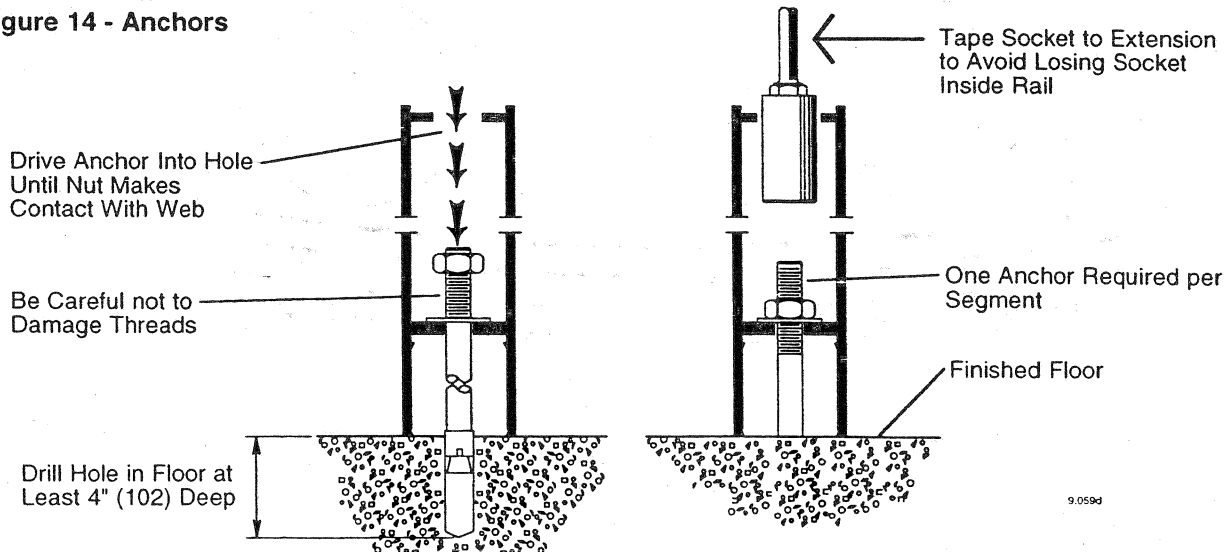
Figure 13 - Leveling Drum



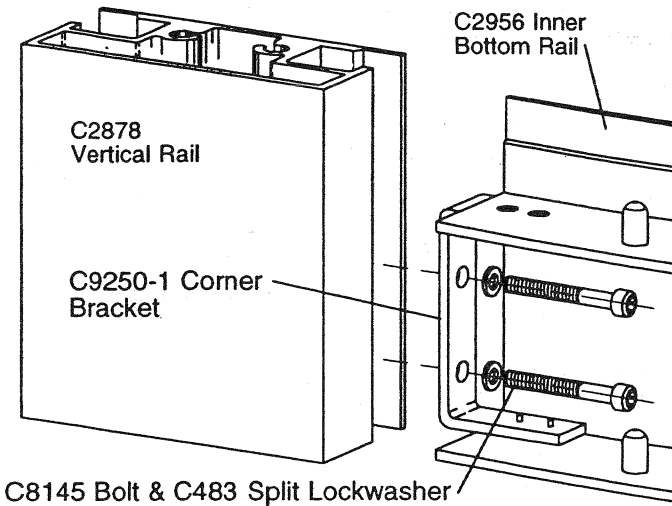
10. JOINING DRUM HALVES - See P.13 for Round Drum

- A. Using the outside diameter of the circle laid out previously (Figure 1 & 2) place the drum halves in their approximate positions as shown in Figures 10 & 11 and join them together with the center (canopy) sections assembled in Figures 8 & 9.
- B. Line up the drum halves by centering the center vertical rail on the centerline. The rounded part of the vertical rails should touch the circle drawn in Figure 2 (See Figure 11 - Detail A).
- C. When you are sure of the accuracy of the previous steps you will be ready to anchor the drum to the floor with the 5" (127) Hilti type expanding anchors that are provided. For best results start in the center, making sure that the drum has not shifted out of alignment. Place 3/8" (10) x 12" (305), or longer, masonry bit through clearance hole in the bottom rail and drill at least 4" (102) into the concrete. Place each anchor through the bottom web and drive it into the concrete until it bottoms against the web taking care not to damage threads. **HINT: To prevent thread damage, take a spare Hilti type anchor with a nut just barely started on threads. Use this anchor as a tool to drive anchor into concrete. If threads are damaged, the anchor could spin in the concrete and fail to tighten. Use a 9/16" (15) deep socket with an extension to tighten nuts. HINT: Tape socket to extension to avoid dropping the socket inside the rail (Figure 14).**
- D. Determine if the drum is level with a transit or by using a straight edge with a spirit level across the bottom rails as shown in (Figure 13). If necessary, place horseshoe shims (provided) under the vertical rails to make the drum level, front to back and side to side. It is not possible to shim under the horizontal rails because of the hollow web (Figure 13).

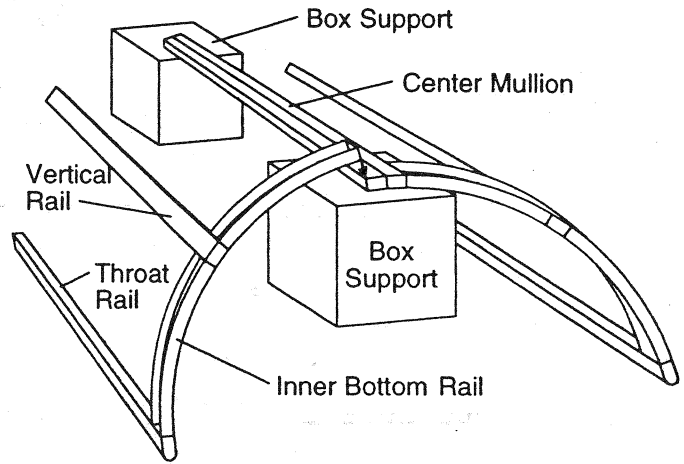
Figure 14 - Anchors



**Figure 15 - Bottom Drum Rail Assembly**



**Figure 16 - Vertical Rail Assembly**



## 11. ROUND DRUM ASSEMBLY

- A. Place all extrusions into groups to match all like parts. Lay out materials on provided packing or similar material to protect finishes. Remove the exterior bottom rail half to access brackets and mounting holes. Assemble wall verticals and bottom rail sections (Figure 15 & 16). Vertical rails and bottom rails are usually not match marked and can be used in any position. The wall halves are unstable until attached to the canopy and must be supported during erection.
- B. Assemble wall halves to canopy using the threaded studs installed in vertical rails and center mullions (Figure 18). Brace drum section until canopy sections are installed.
- C. Position drum and align bottom rails with O.D. line as mentioned in Figure 2. Verify that throat openings are equal. Secure bottom rails to floor with 3/8" (9.5) Hilti anchor bolts (Figure 17). Leave exterior half of bottom rail (C2957) off until ready for curved glass installation.

**Figure 17 - Round Drum Anchorage**

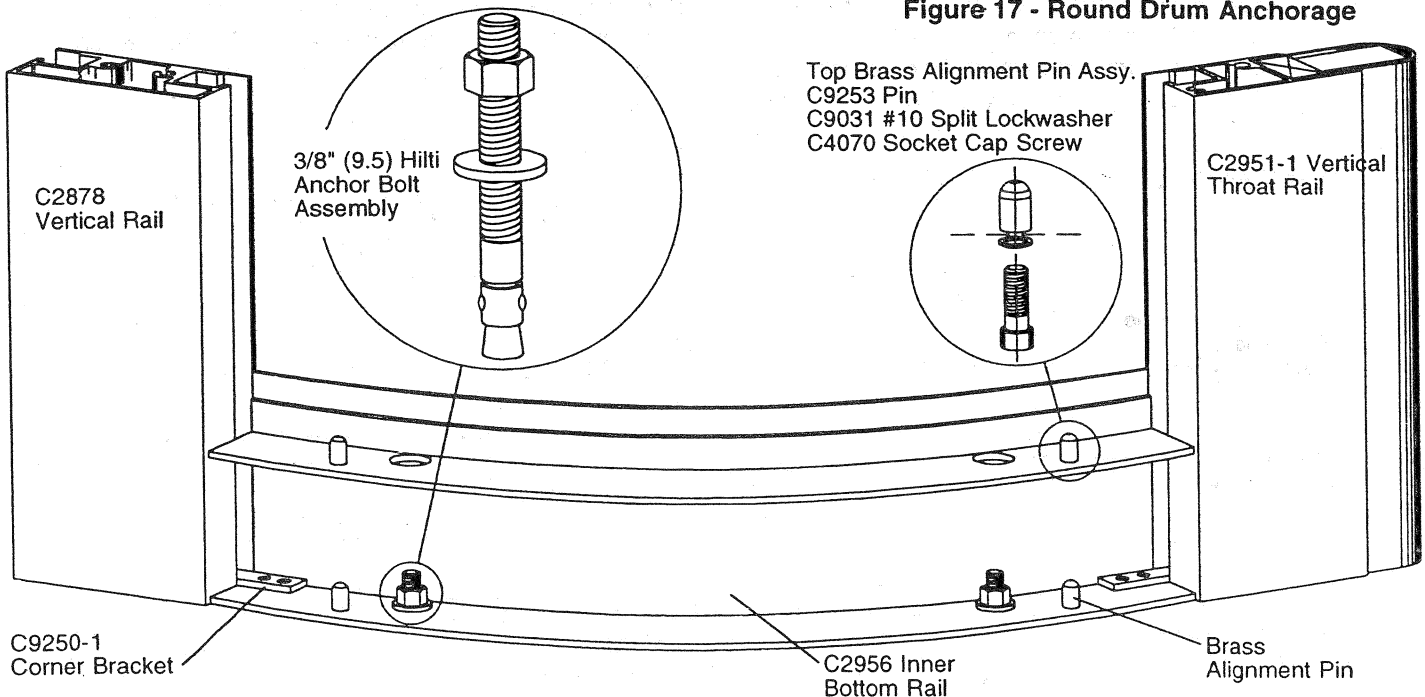
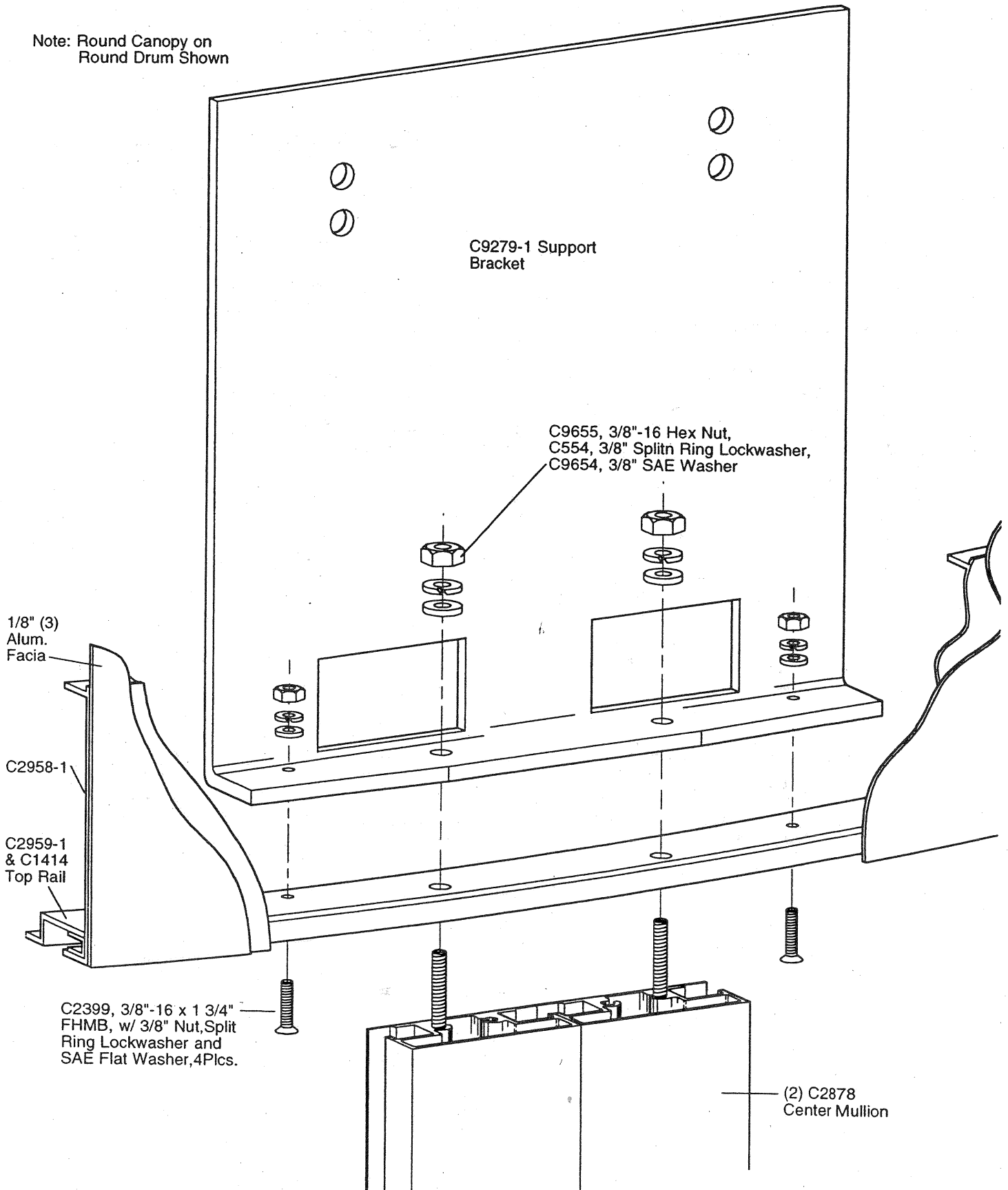


Figure 18 - Gear Train Support Bracket  
Installation (Round Canopy)

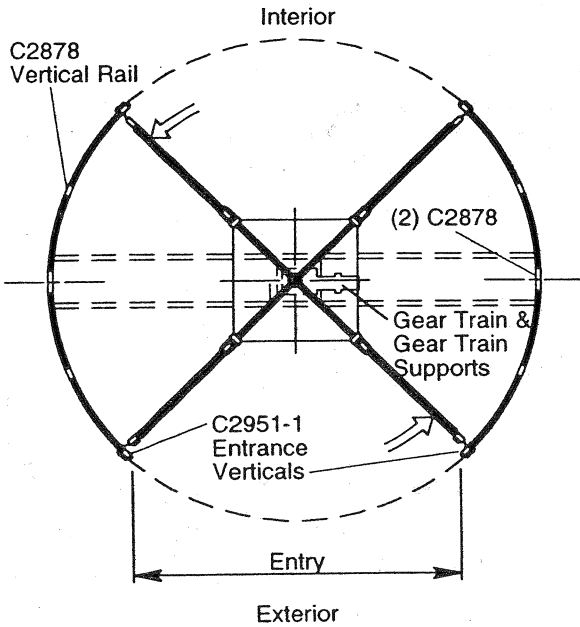
Note: Round Canopy on  
Round Drum Shown



## 12. ROUND CANOPY ATTACHMENT

- A. Set canopy sections (4 or 6) onto drum wall sections (see Figures 20 & 23). Attach using factory installed threaded studs protruding from wall verticals rails. Secure with flat washer and nut at each end.

Figure 19 - Round Drum Orientation



Note: 4-Wing shown  
3-Wing Similar

Figure 20 - Round Revolving Door Canopy

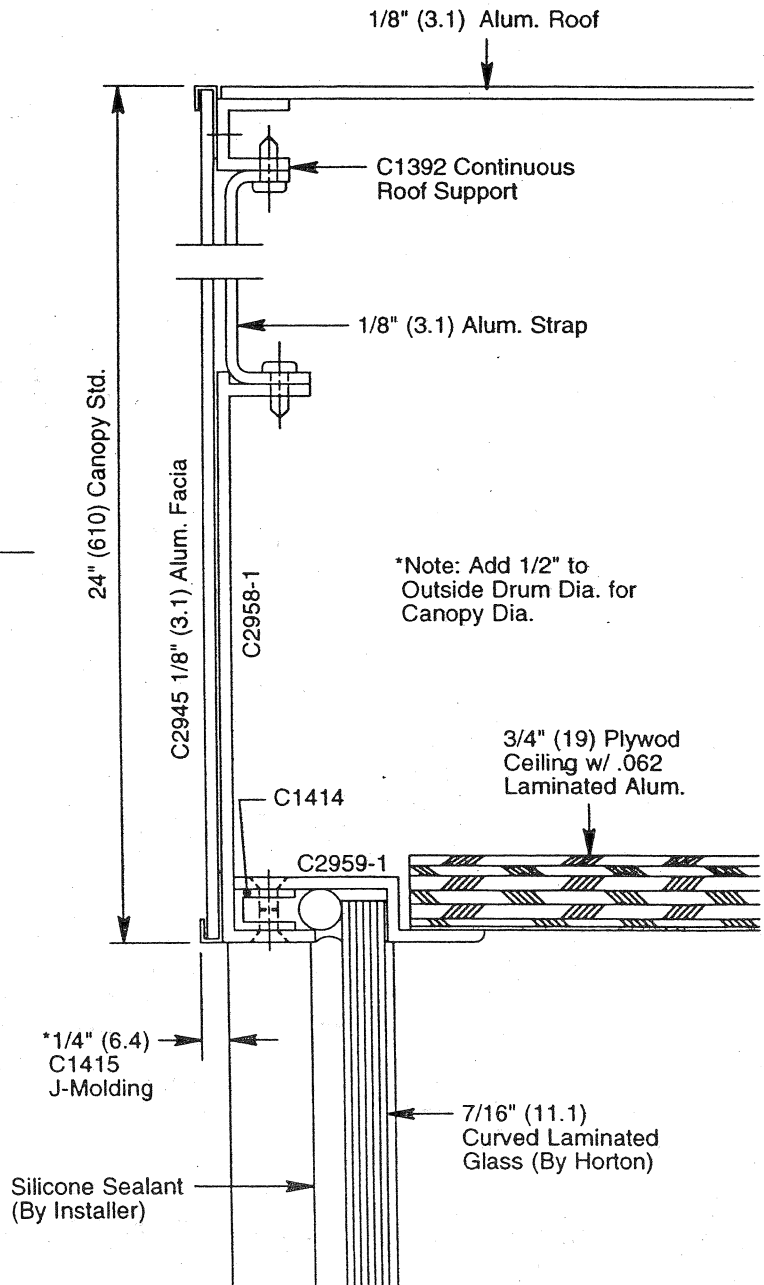
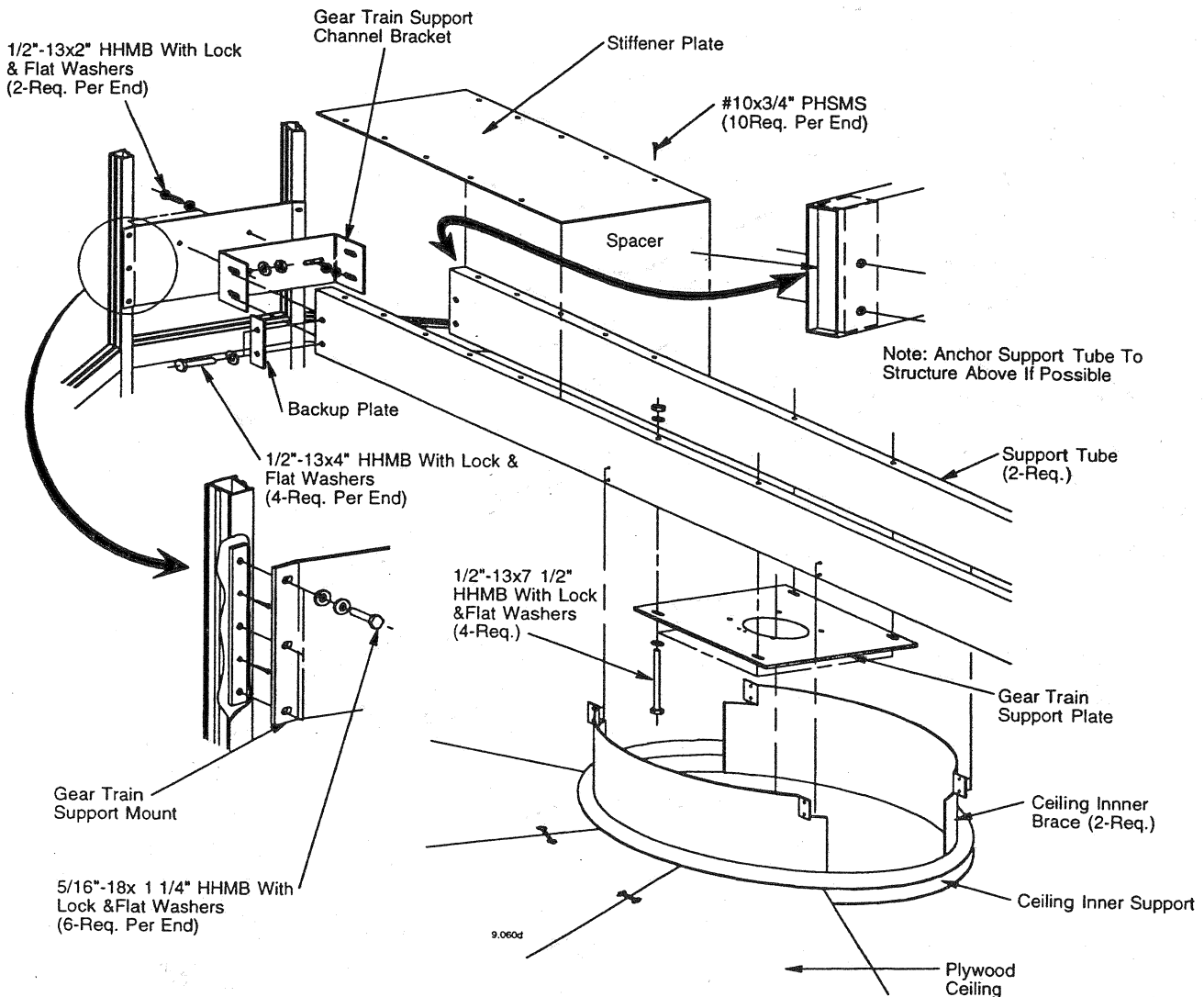


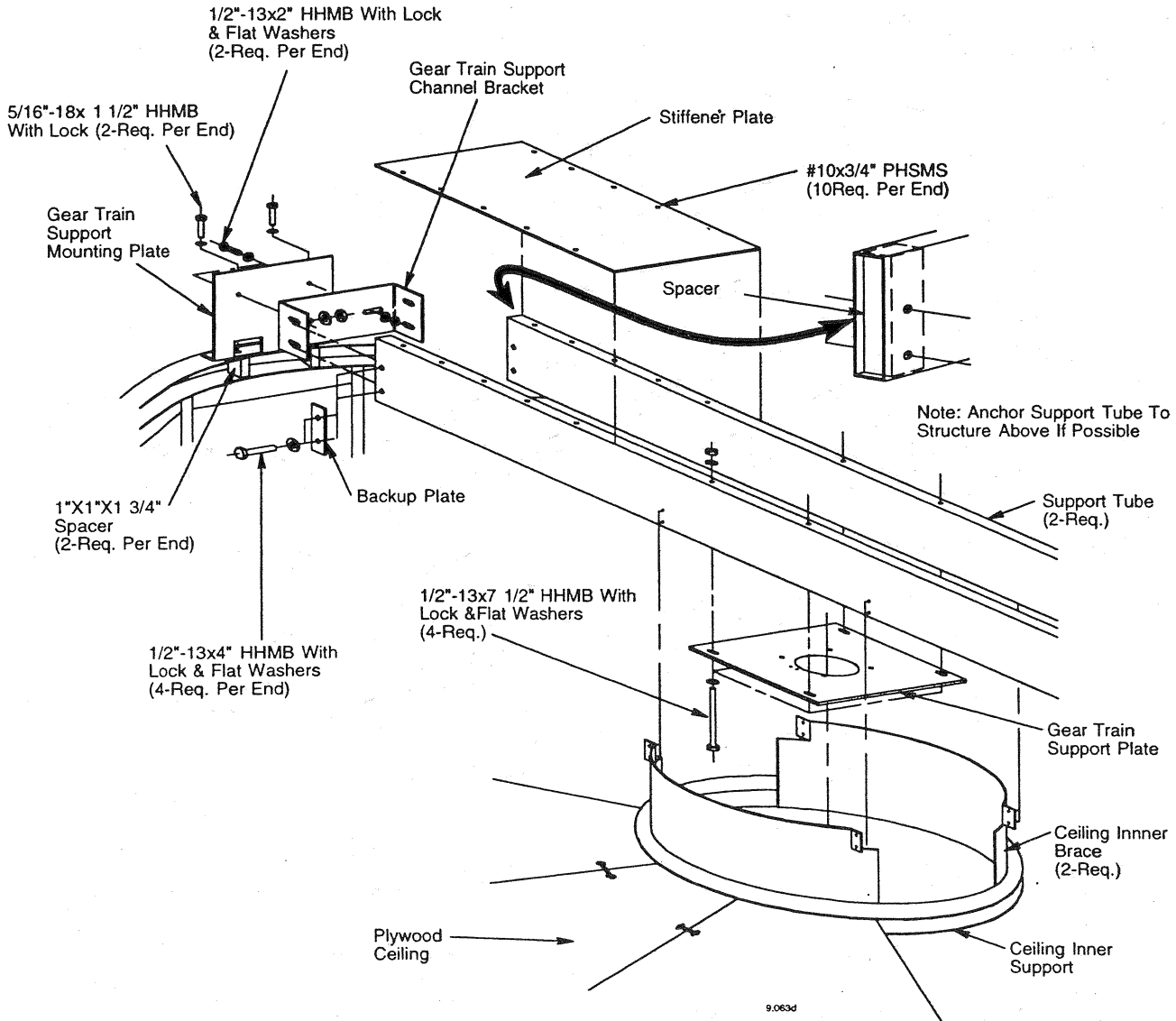
Figure 21 - Gear Train Support  
(Segmented Canopy)



### 13. INSTALLING GEAR TRAIN SUPPORT

- A. Figure 21 (Segmented Canopy). Install the gear train support mounts with (6), 5/16" - 18 x 1 1/4" HHMB with flat & lock washers. Refer to Figures 7 & 10 for proper location.
- B. Figure 12 (Round Canopy) Install canopy sections per match marks using C565 #10 x 3/8" pan head sheet metal screws. The outside face of the 1/8" (3) thick aluminum canopy fascia panels should be flush and plumb with the outside face of the vertical rails. Connect tops of canopy sections with C437 FSMS provided. Align vertical canopy fascia joints for a flush & tight fit.
- C. Install the (2), 1/4" (25) thick, primed steel gear train support mounting plates to the top of the C2961 2" (51) x 2" (51) x 2" (51) channel with the (4), 1" (25) x 1" (25) x 1 1/2" (38) high aluminum spacers. Fasten with 5/16"-18 x 1 1/2" HHMB with flat & lock washers.(Figure 20). Do not snug bolts until gear train support tubes are in place. (For round canopy see Fig. 22)
- D. (Round Revolver Design) Install the C9279-1 support brackets at top of the doubled center verticals (C2878) (see figure 22).
- E. The gear train support assembly may now be lifted into place and bolted to the gear train support mounting plates with (4), 1/2" - 13 x 2" HHMB with nuts, lock & flat washers. Run the bolts in from the outside so the threaded part does not interfere with the canopy panels. Center the bolts in the slots, and leave finger tight at this time (Figures 21 & 22).

**Figure 22 - Gear Train Support  
(Round Canopy)**



## 14. INSTALLING GEAR TRAIN

- A. Determine easiest service access to canopy, The gear train can be turned either right or left depending on which will be more convenient for installation and service of the motor and quarter point switch. Place the gear train on top of the gear train support plate with motor end toward the service area and line up the four holes around the base. Install the (4), 1/2" - 13 x 2" HHMB with nut, flat & lock washer from the bottom (Figure 23).
- B. Check the vertical rails for plumb (Figure 24). It may be necessary to brace the top of the drum to a wall to hold it in place until alignment is complete.
- C. Place the quarter point disk on gear train being careful not to lose the small key that fits into the key way in the gear train. Insert the C896 1/8" (3) dia. x 3/4" (19) long roll pin through key to secure.
- D. Drop a plumb bob through the gear train using the hole provided in the quarter point disk. The point of the plumb bob should fall directly on the center mark made in Section 1. If the plumb bob does not line up with center point mark, the gear train position may be adjusted using the slotted holes in the gear train support channel bracket and the gear train support plate (Figure 25).
- E. When proper alignment with the center point has been achieved, level support tubes then tighten the mounting bolts on the gear train support (Figure 25).

Figure 23 - Mount Gear Train

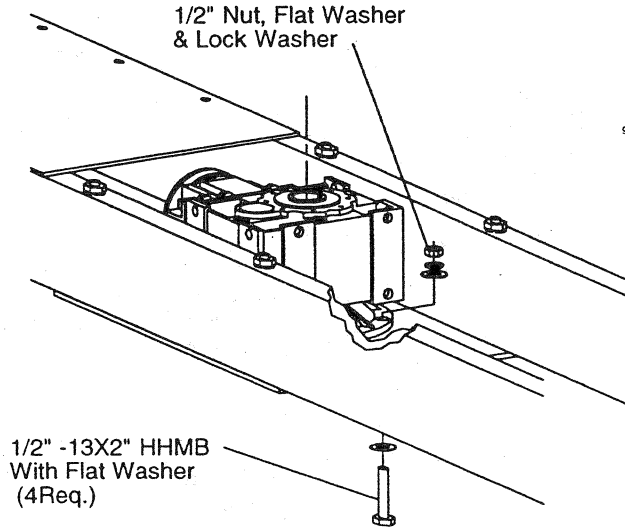


Figure 24 - Plumb Vertical Rails

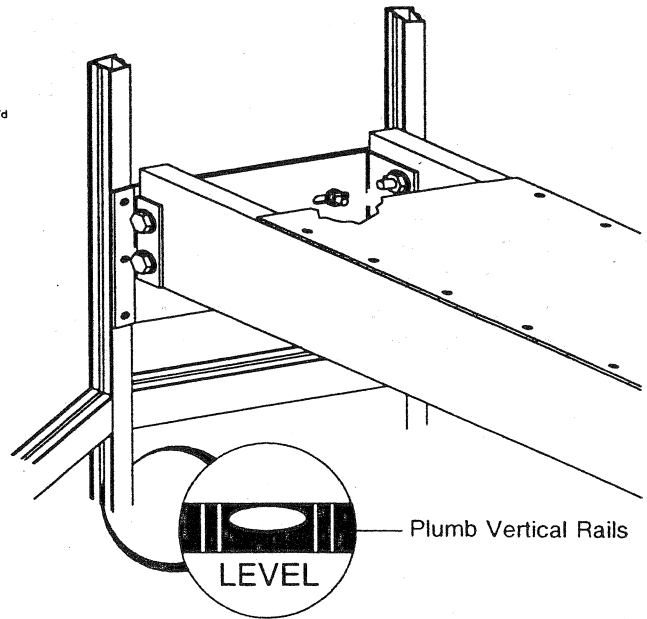
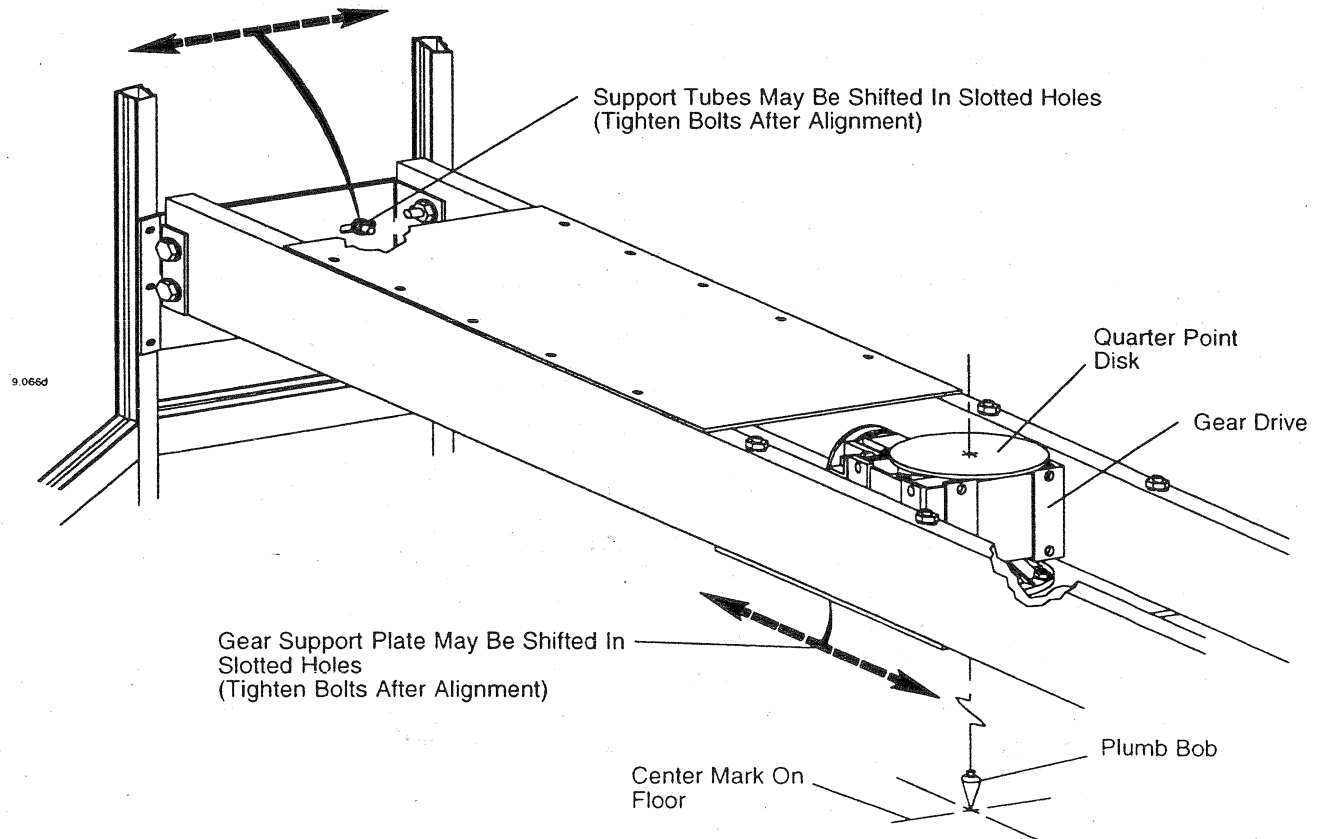


Figure 25 - Gear Train Alignment

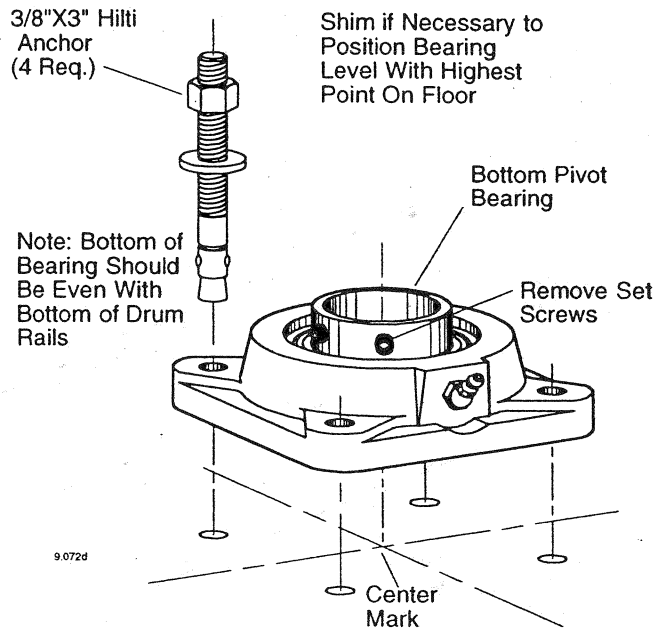




## 15. INSTALLING BOTTOM BEARING

- A. Place the bottom bearing on the center mark and anchor to the finished floor with (4), 3/8" (10) x 3" (76) Hilti anchors. It should be level with the highest point on the floor, shim under the bearing if necessary. This is a self-leveling bearing and the race swivels inside the housing. Remove the set screws. Check bearing for grease. A small amount of grease should be visible along the seals. Should bearing require greasing, use Mobil "Mobilux EP-2 X30 M4 premium lubricant or equal. Do not use more than one squirt with a grease gun as too much grease will destroy the seals resulting in bearing failure. Once loosely secured, the bearing can be moved by tapping lightly with a block of wood and hammer. (Figure 26).

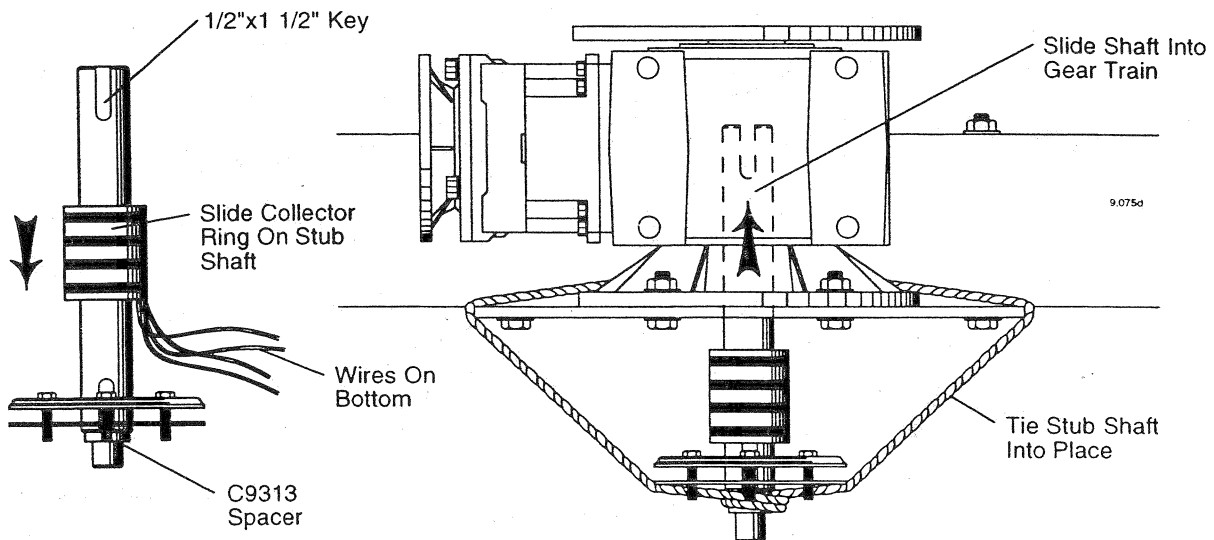
Figure 26 - Bottom Bearing



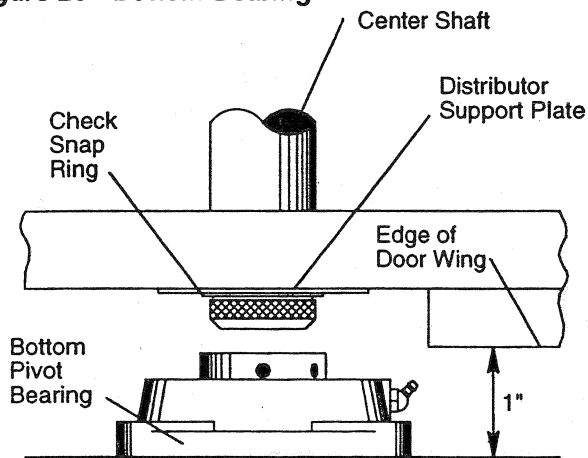
## 16. INSTALLING CENTER SECTION

- A. Place collector ring assembly on the stub shaft with the wires located nearest the flange. Place the 1/2" (13) x 1 1/2" (38) key in the key way at the top of the shaft (Figure 27).
- B. Apply the anti-seize lubricant provided to the stub shaft, push it as far as possible into the gear train and secure with utility rope (Figure 27).

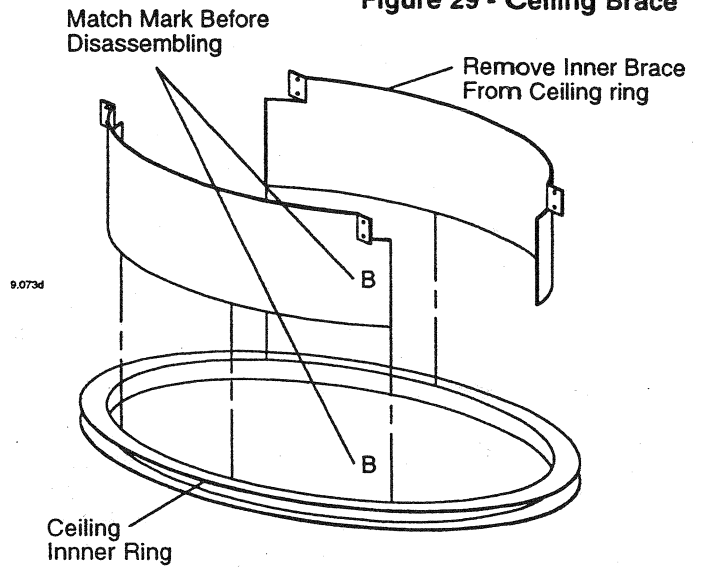
Figure 27 - Stub Shaft installation



**Figure 28 - Bottom Bearing**

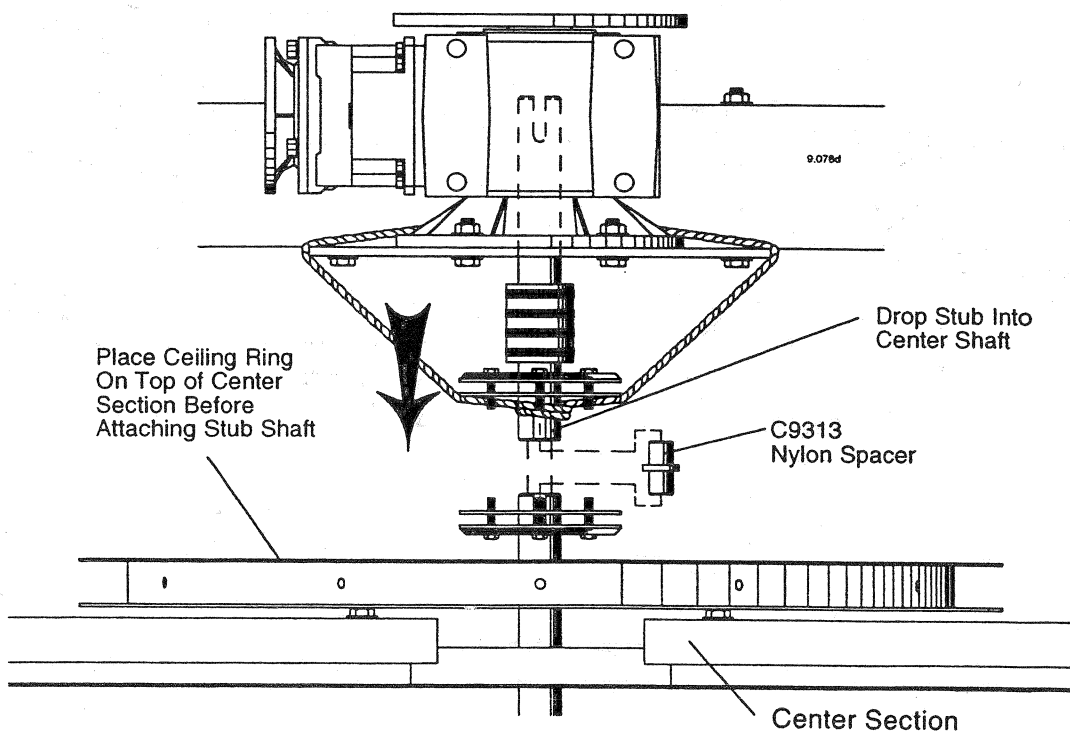


**Figure 29 - Ceiling Brace**



- C. Turn the center section on its side (to clear the entrance canopy) and check to see if the bottom snap ring is in place (Figure 28) While center section is on its side, install the 12" (305) long pieces of right angle weatherstrip to ends of closer arms. (2 per wing, see weatherstrip installation drawing-Fig.37) . Carry the center section into the drum and set it right side up with the shaft in the bottom bearing. The snap ring should rest on face of bottom bearing. Shaft engages bearing approximately 5/16" (8). Check the bearing to make sure the shaft is properly inserted (Figure 28). The center section will now rock side to side at this time due to the self aligning bearing. Remove one of the ceiling inner braces from the ceiling inner ring and with rope, tie up to the support tubes. (Figures 29 & 30).
- D. Remove the rope from the stub shaft and allow the alignment pin to drop into the receiving bore of the center shaft (Figure 30).
- E. Loosen all bolts as far as possible in flanges A and B in Figure 32. Place the `rubber tire` (Dodge flexible coupling - see figure 31) between the two plates of flanges A and B. Work all the way around until there is no gap where the ends of the "rubber tire" come together (Figure 32). Tighten all bolts in flanges A and B until they are snug.

**Figure 30 - Center Section Attachment**



## 17. C9373-1 COUPLING ASSEMBLY

- A. Begin the assembly procedure by positioning the bottom of the coupling flange and Taper-Lock even with the bottom end of the stub shaft. If the flange is not in the position shown in the drawing below, turn the flange over so the Taper-Lock bushing points downward. The flanges are reversible (Figure 31).
- B. Torque the setscrews to 280 in/lbs or (24 ft/lbs). Use the integral key Taper-Lock (C9364 Dodge PN119265). If you have a separate key, replace the bushing with the proper one mentioned above (Figure 31).
- C. Position the top of the other coupling flange and Taper-Lock even with the top of the main shaft as shown. Again, make sure the Taper-Lock bushing points downward as illustrated below (Figure 31).
- D. Repeat step B.
- E. Slide the stub shaft and the C9313 spacer into the main shaft. Loosen the clamp ring bolts and insert the rubber tire as shown. Use a small mallet to make sure the tire is properly seated and the split is closed. Tighten the clamp ring bolts to 280 in/lbs (24 ft/lbs) (Figure 31).

Figure 31- C9373-1 Coupling Assembly

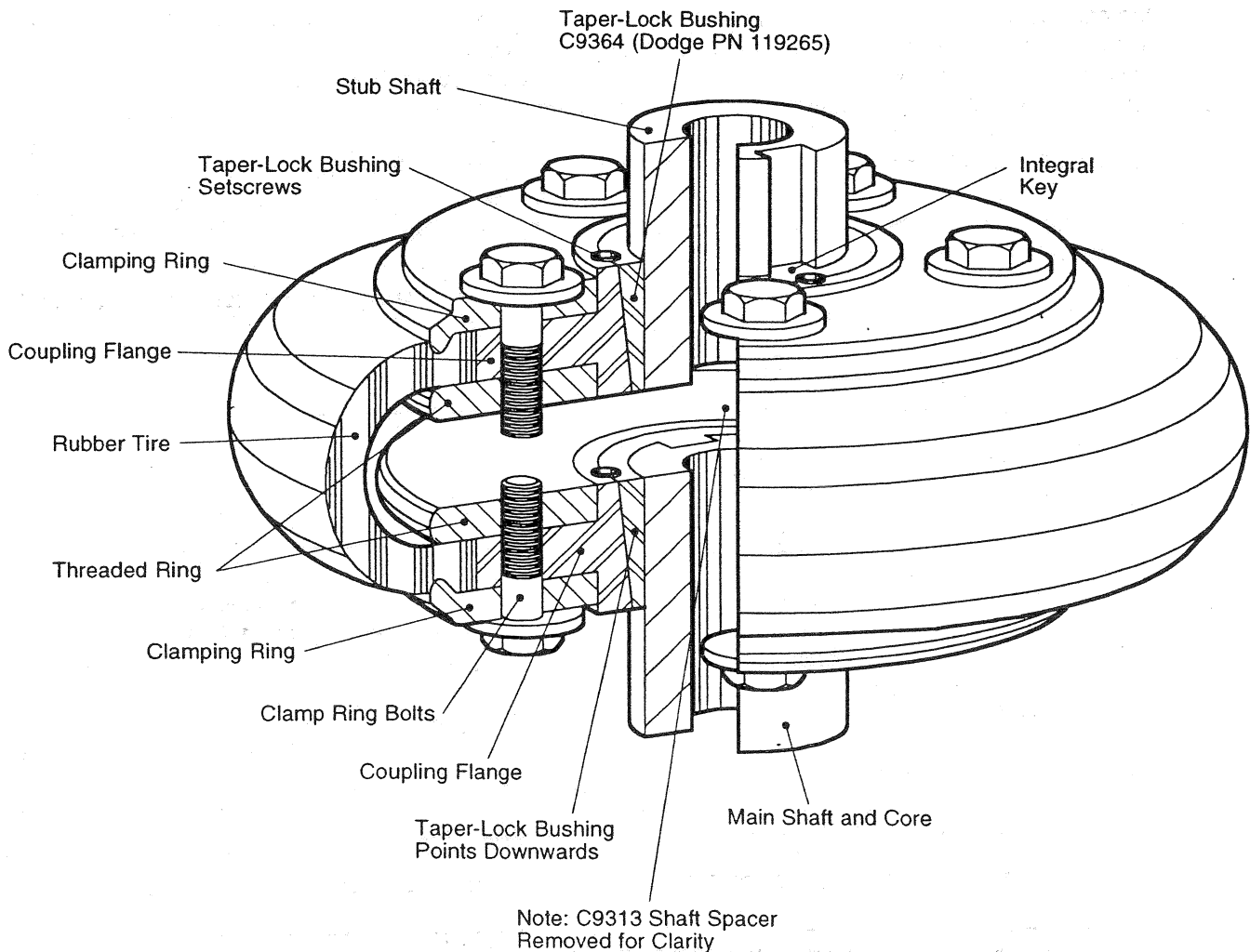
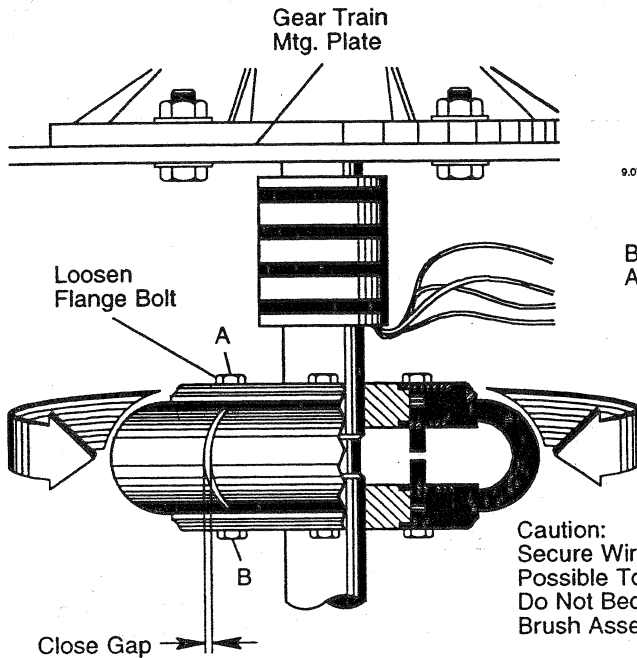
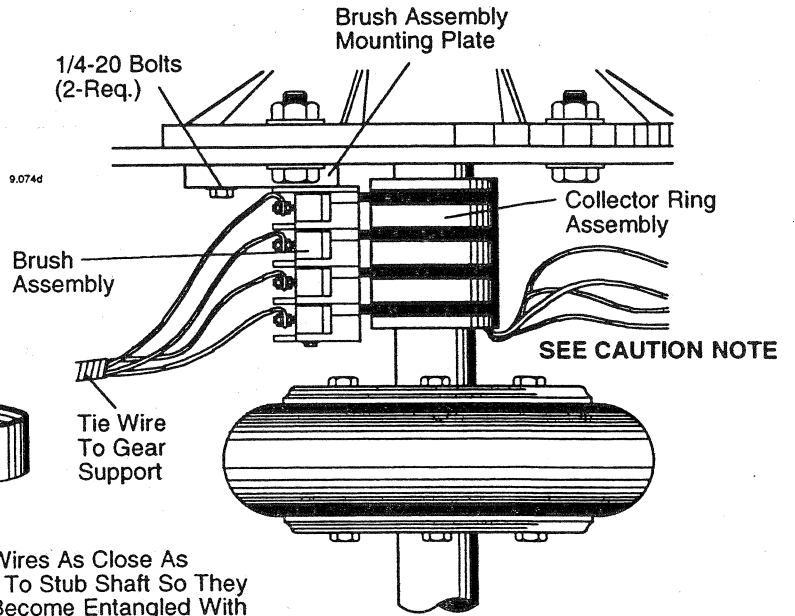


Figure 32 - Coupling



Caution:  
Secure Wires As Close As Possible To Stub Shaft So They Do Not Become Entangled With Brush Assembly

Figure 33 - Brush Assembly



18. BRUSH ASSEMBLY

- A. Approximate the location of the collector ring by holding the brush assembly in place and sliding the collector ring assembly up the shaft until the brushes are lined up with the brass rings (Figure 33). NOTE: This should be done from below because additional weight on the gear train support may affect alignment. Tighten set screws to hold ring assy. in place.
- B. Wire and attach the brush assembly to the brush assembly mounting plate with the machine screws that run through the brush assembly. Mount the plate to the bottom of the gear train mounting plate with 1/4" x 20 bolts (Figure 33). Attach the wires to the brush assembly terminals in the order shown in Figure 33. CAUTION: Use a volt meter to verify colored wire continuity through brush assembly and collector ring C. Push the brush assembly against the brass rings (this will depress the brushes) until the holes in the brush assembly line up with the threaded holes in the bottom of the gear train mounting plate. (Approximately 1/4" (6) gap between ring and depressed brushes). Tighten all set screws. Check for clearance between "rubber tire" coupling bolts and bottom of brush assembly. Tape or secure loose wires to prevent entanglement once revolver begins to rotate.

Figure 34 - Ceiling Supports

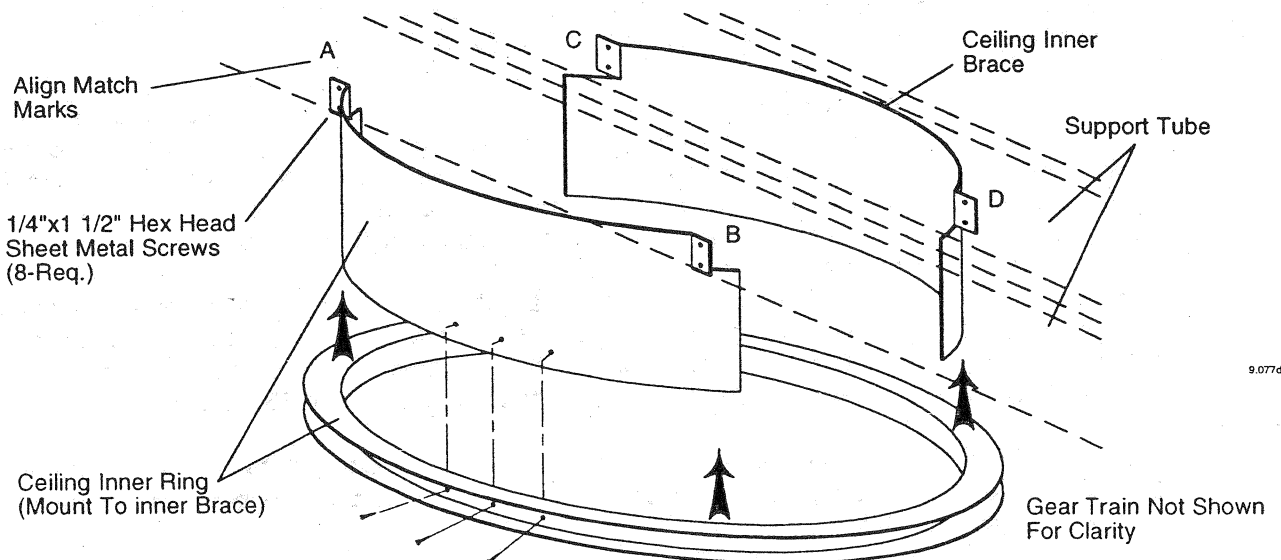
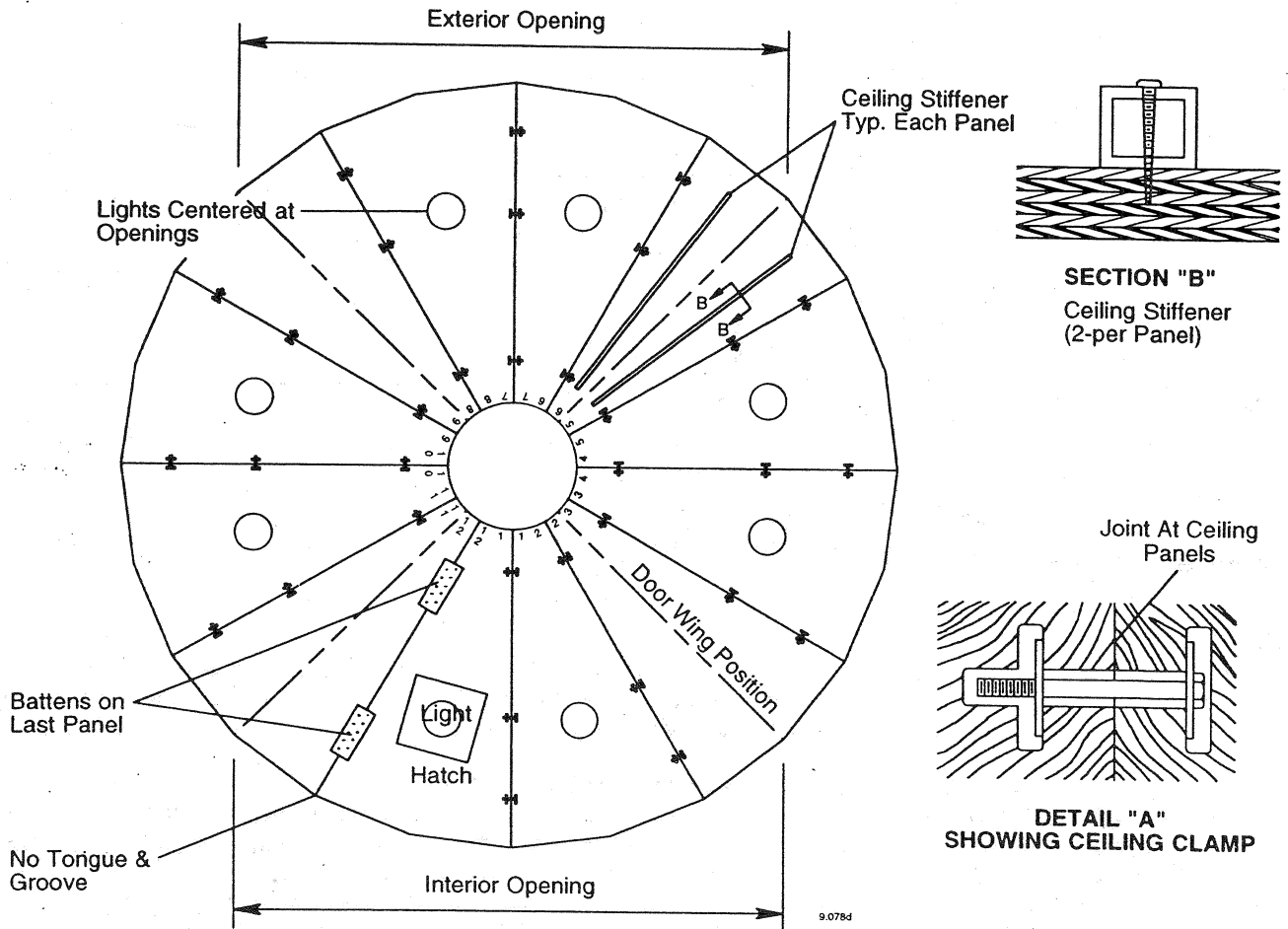


Figure 35 - Ceiling Panel Locations



### 19. INSTALLING CEILING SUPPORT (Removed in step 16C)

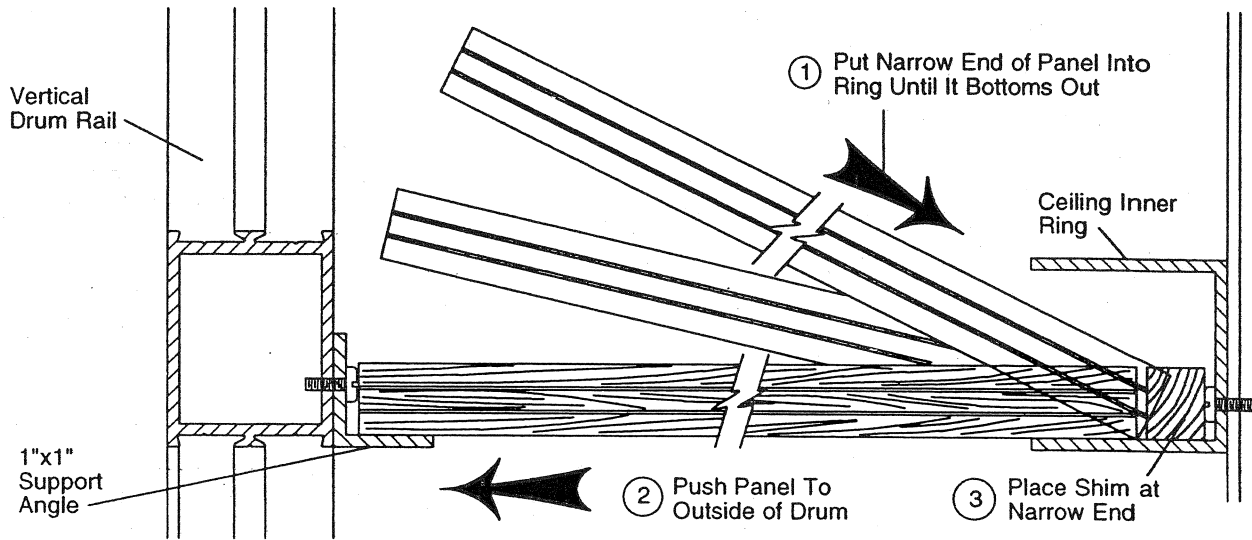
- A. Align the match marks on the ceiling inner brace with the marks on the gear train support tubes and mount with #14 (4.6) x 1 1/2" (38) hex head sheet metal screws (Figure 34). Mount the ceiling inner support ring to the inner brace with (16), #10 (4.8) x 5/8" (15.8) pan head sheet metal screws. The screws will protrude towards the center of the revolver (Figure 34).

### 20. INSTALLING CEILING PANELS

- A. Remove the protective plywood strips from the tongue and groove edges of the ceiling panels and pull back protective plastic from edges and inner portion over center section only. **HINT: Cut protective plywood strips into 2" (50) long pieces and use to shim out at narrow ends of ceiling panels.** The narrow ends of the panels are match marked (Figure 35, A). Orient the panels so the lights are positioned as shown in Figure 35. The access hatch is usually located on the secure (interior) side of the door with the lights centered at the openings.
- B. Begin with the panel marked 12 - 1 (Figure 35). Place the panel in the position indicated with the narrow end into the ceiling inner ring. Panel should bottom out. (Figure 36, Step 1) Lower the panel on to the 1" (25) x 1" (25) ceiling support angle and push panel firmly against outside of drum (Figure 36, Step 2). Place cut plywood shims at ceiling inner ring (Figure 36, Step 3).

**Notice: Without shims, panels can fall out and cause serious damage to the panels or the installer. If each panel is not sitting as far to the outside of the drum as possible, the last panel will overlap and not fit into place.**

Figure 36 - Ceiling Panel Installation



- C. Check the match mark on the point of the `12 - 1` panel and select the next panel marked `1-2`. Place panel in the same manner as in section 20.B and push the pieces together closing the tongue and groove gap. As each panel is installed, install the ceiling clamps securely in each slot that is routed for them, being careful to ensure that outer edge of panel is firmly against 1"x1" support angle (Figure 35, Detail `A`) Continue this process until all the ceiling panels are installed (Figure 35).
- D. The last panel has no tongue and groove, so it must be fastened with battens which are provided, and outlined on the `12 - 1` panel (Figure 35).
- E. Remove rest of protective plastic from ceiling panels.
- F. Install two ceiling stiffener tubes per panel with screws provided. Place tubes to avoid the hatch, lights, etc. (Figure 35, Detail `B`).
- G. Install ceiling lights with hat shaped strap tie-downs.
- H. If canopy is round, install (4 or 6) C9099 curved canopy back-up plates. Attach to inside of canopy fascia panels with double faced tape to cover joints.

## 21. INSTALLING WEATHER-STRIPPING AT CENTER SECTION

- A. Refer to weatherstrip installation instruction drawing (Figure 37) and attach horizontal nylon brush weather-strip to top and bottom of center section with double sided tape and screws (supplied). Attach closer cover weather-strips with double sided tape.
- B. **CLEAR CORE:** An access panel is provided at the sloped bottom portion of the center section to allow access to wiring connections and bottom bearing. Panel is held in place with J-mold strips and (4) small FHSMS fasteners (Figure 38).  
**DISPLAY CORE:** An access panel is provided at the bottom portion of the center section. It can be removed by removing the (3) HHMB fasteners at the bottom outside edge of panel. Panel then lifts up and out (Figure 39).

**Figure 37 - Weather Strip Installation**

Insert C9281 1 1/2" Horsehair W/S Into Receptor in Top Rail C2963 (4 per)

Screw with C8307 #10-24 x 1/4" (6) Pan Hd. Sheet Metal Screws and Tape Apply C299-1 5/8" x 12" Long Vinyl Sweep to Arm. Align With Door Sweep (8 per). Install Prior to Installation of Clear Core- See "B-B"

See "A-A" Overlap 3" (76) and Bend at 90° - Trim Excess as Req'd.

Insert C9282 2 1/2" Horsehair W/S into C2990 Sweep Attachment (4 per)

Overlap 3" (76) and Bend at 90° - Trim Excess as Req'd.

Insert C9423 1 3/8" (35) Vinyl Sweep Into Receptor on Bottom Rail C2963 (4 per)

Tape Apply C296/9425 1" (25) Vinyl Sweep to Exterior Face of Core Cover @ Top & Bottom (8 per)

Tape Apply C294-1 1/2" (12) Vinyl W/S to Closer Top & Bottom (32 per)

C299-1 W/S w/ C8307 Screws Extend to End of Closer Cover

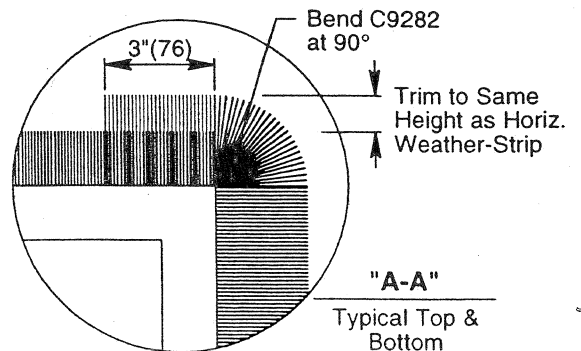
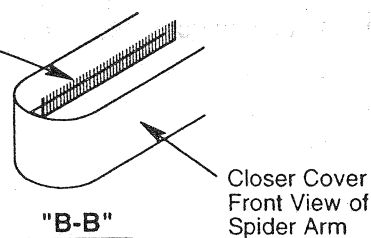
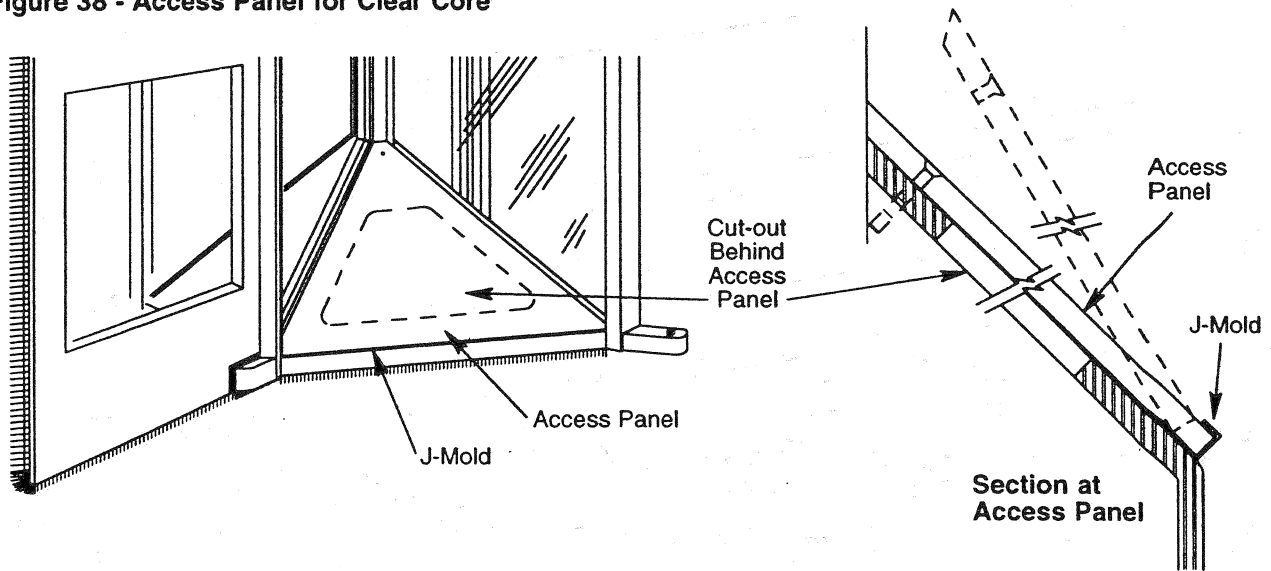


Figure 38 - Access Panel for Clear Core



## 22. INSTALLING REED SWITCHES

- A. Mount the C9337 switch bracket under each of the top spider arms with #10 - 24 x 3/8" round head machine screws (Figure 40). Push the C9338 reed switch through the offset hole in the bracket (Figure 40).
- B. Attach a piece of 4 conductor wire approximately 12" (305) long to the 3'(915) conductor coming from the collector ring assembly (Ref. Section 8B). Route the red and black wires from the switch over the dummy or top closer pivot and into the center section. From the switch: Splice the red to the white and the black to the black wire from the 4 conductor collector ring cable (Figure 40, Detail 'A').

Figure 39 - Access Panel for Display Core

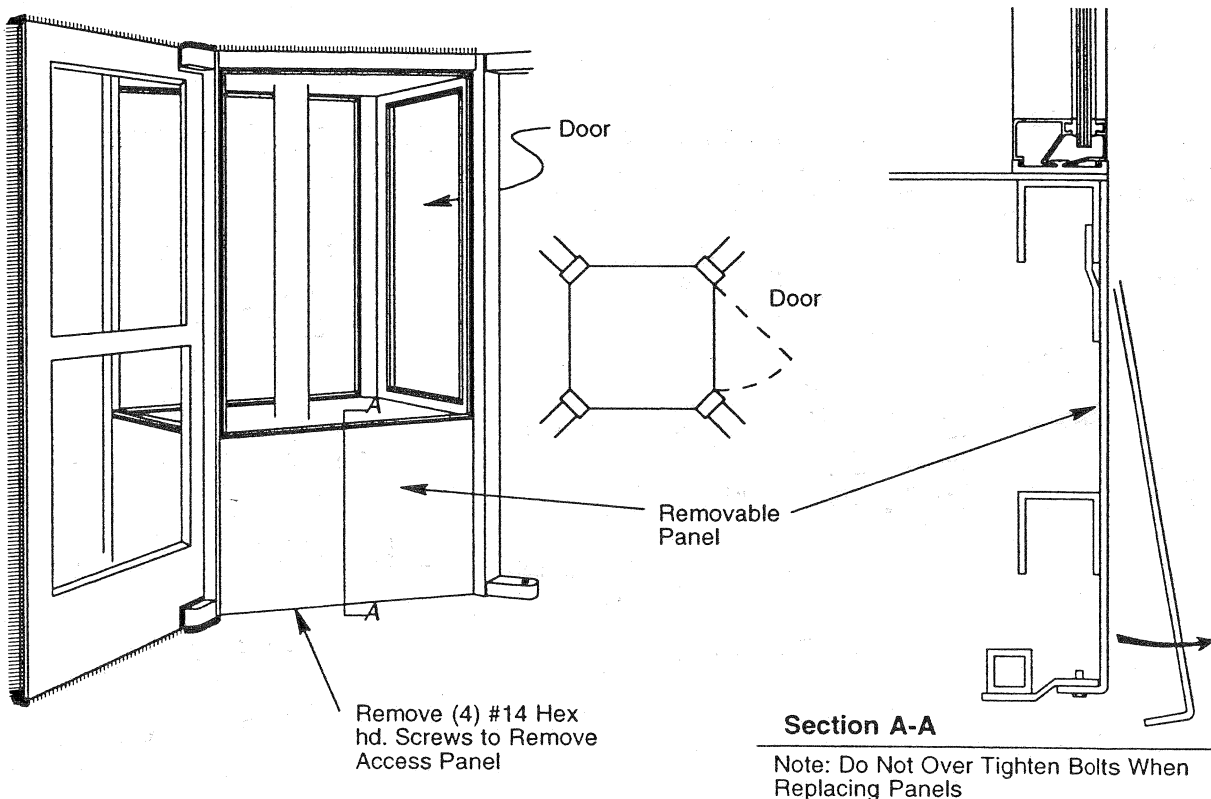
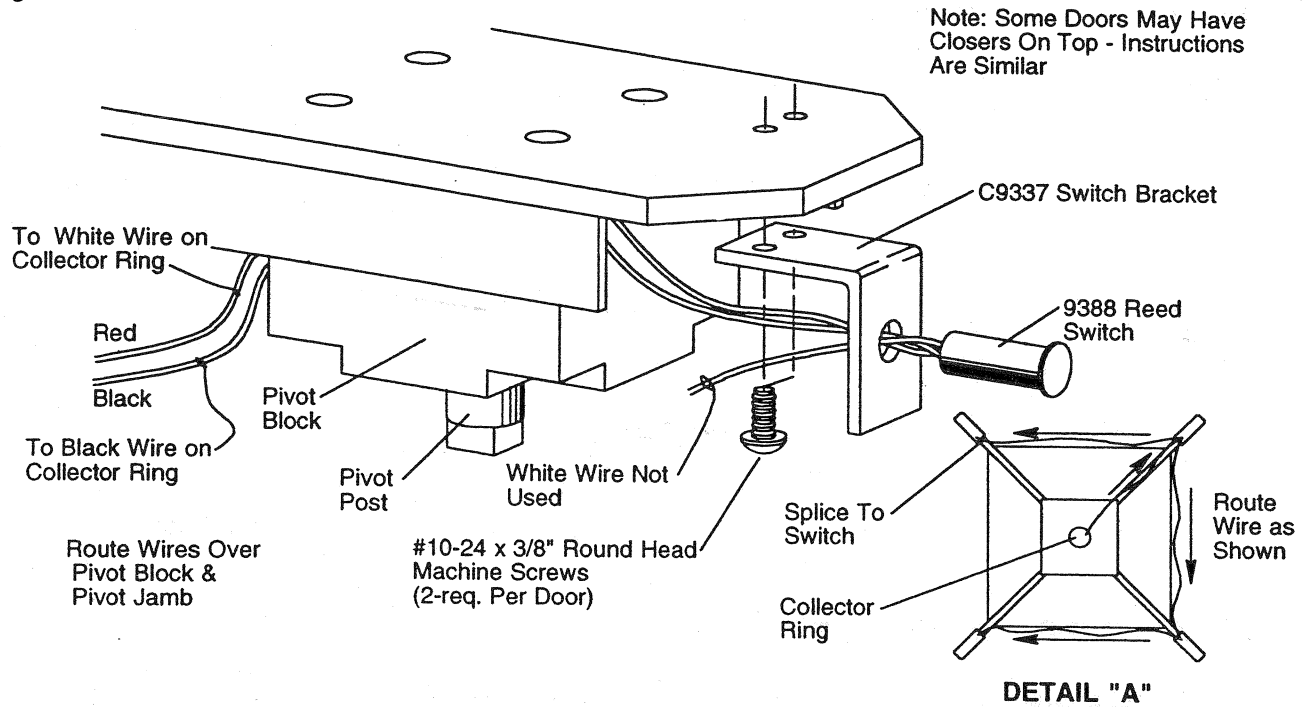




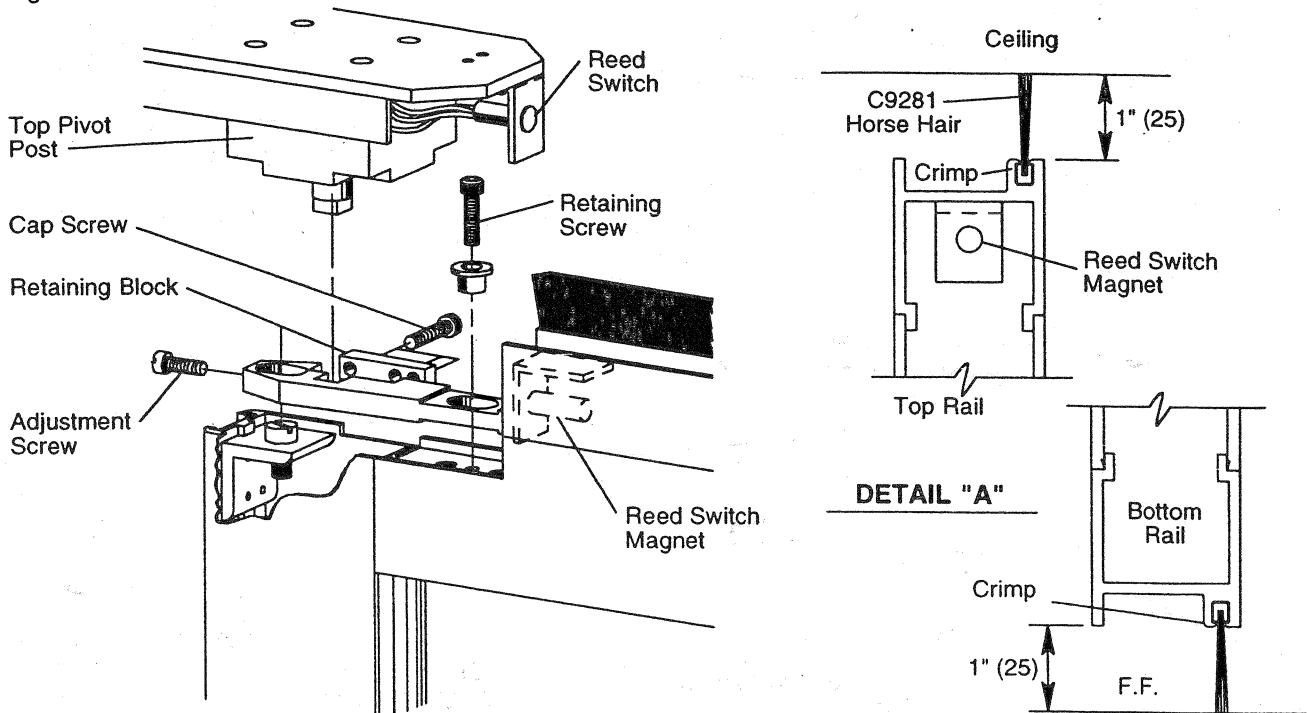
Figure 40 - Reed Switch Installation



### 23. INSTALLING DOOR PANELS

- A. Lay door panel flat on saw horses. Slide the weather-strip into the slots on top and bottom of the door. Crimp in place. Install vertical horsehair weather-strip on door panels. Overlap 3" (76) on top and 3" (76) on bottom and bend over at 90 degrees. (Figure 41, Detail 'A').
- B. Place reed switch magnet in the hole in the bracket on top of the door (Figure 41, Detail 'A').

Figure 41 - Door Panels



- C. Install foot-guards. Mark location of foot-guards at door bottom. Foot-guard should touch the heel of person walking in direction of door rotation. Outside edge of foot-guard should align with strike rail approximately 1/4" (3) in from outside edge. (at transition point from curved to flat surface) Clean bottom rails thoroughly with isopropyl alcohol to remove dirt and debris. Remove backing of cladding tape. Bottom of foot-guard should be 1/2" (13) lower than door bottom. HINT: Let screw heads on back of foot-guard rest on bottom web of door panel to gauge the 1/2" (13) overlap required. Pivot foot-guard toward door bottom and carefully attach at marked position pressing evenly, working from bottom toward top.
- D. Clean top rails with isopropyl alcohol to prepare surface for VistaStop installation
- E. Secure VistaStop safety stop assembly to top rail with double sided tape (Figure 43).
- F. Run wiring for foot-guard and VistaStop and make electrical connections per wiring diagrams.
- G. Attach door cord and rubber grommet to pivot stile of door panels.
- H. Remove the three cap screws and the retaining block from the top closer arm assembly (Figure 26). The door panel may be glazed at this time.
- I. Place the bottom corner of the door on the bottom closer so that slot in the door mates with the tab on the bottom door closer. Swing the top of the door up and align the square peg on the top pivot arm in the top pivot post (Figure 41). Secure with the retaining block and three cap screws.
- J. With one door in place, push the door through several revolutions to check top, bottom and side clearance. If necessary, the adjustment screw on the top closer arm may be used to correct alignment (Figure 26). **NOTE: Loosen retaining screw before attempting adjustment and re-tighten after adjustment.**
- K. Repeat procedure in Section 13 for remaining doors.

#### 4. INSTALLING MOTOR AND QUARTER POINT ACCESSORIES

- A. Route the motor lace through the 7' (2134) section of 5/8" (16) flexible conduit, leaving about 6" (152) of wire exposed on each end.
- B. Remove the terminal box cover on the motor, loosen the conduit strain relief screws and insert the end of the conduit without quick connection through the connector with 1/4" (6) of conduit inside the terminal box. Tighten the strain relief screws until the conduit is secure.

Figure 42 - Motor and Quarter Point Indicator

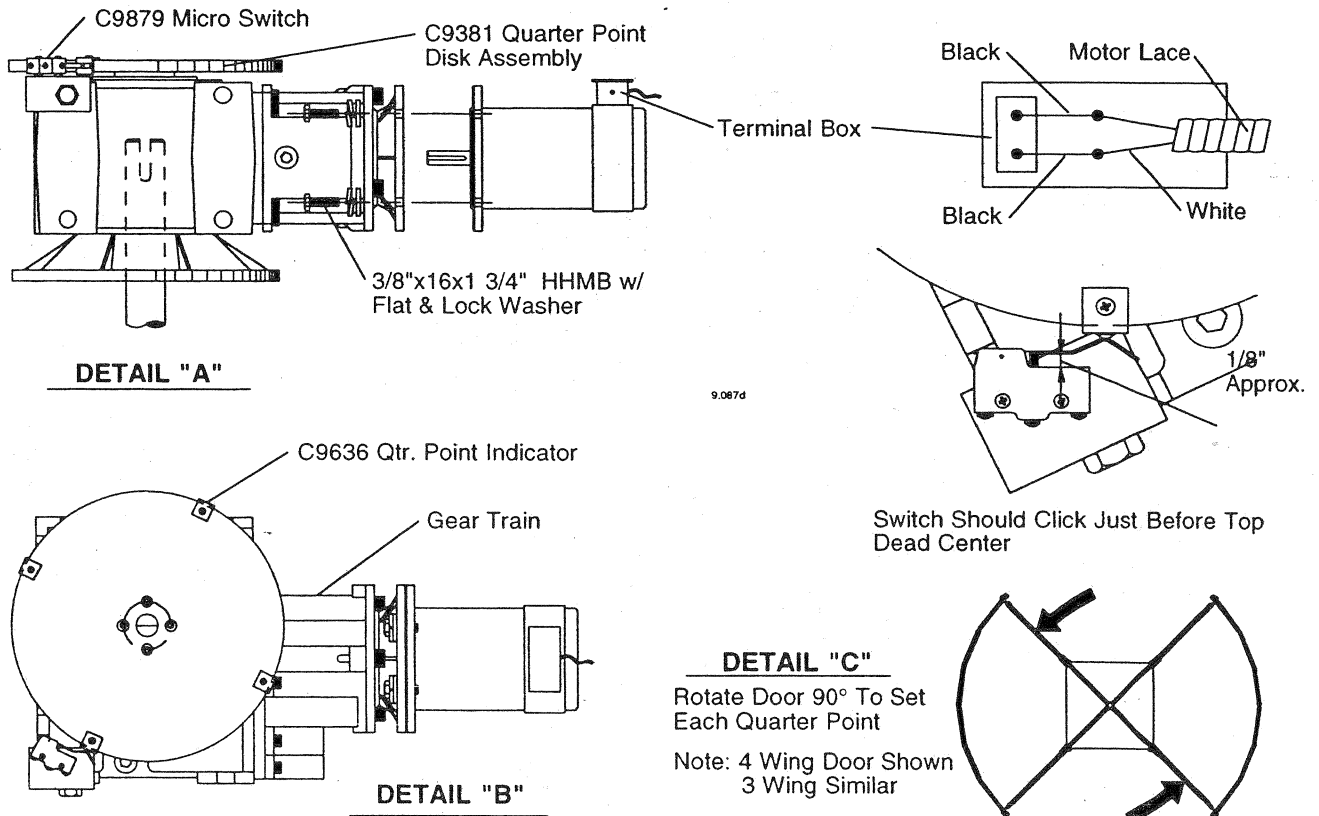
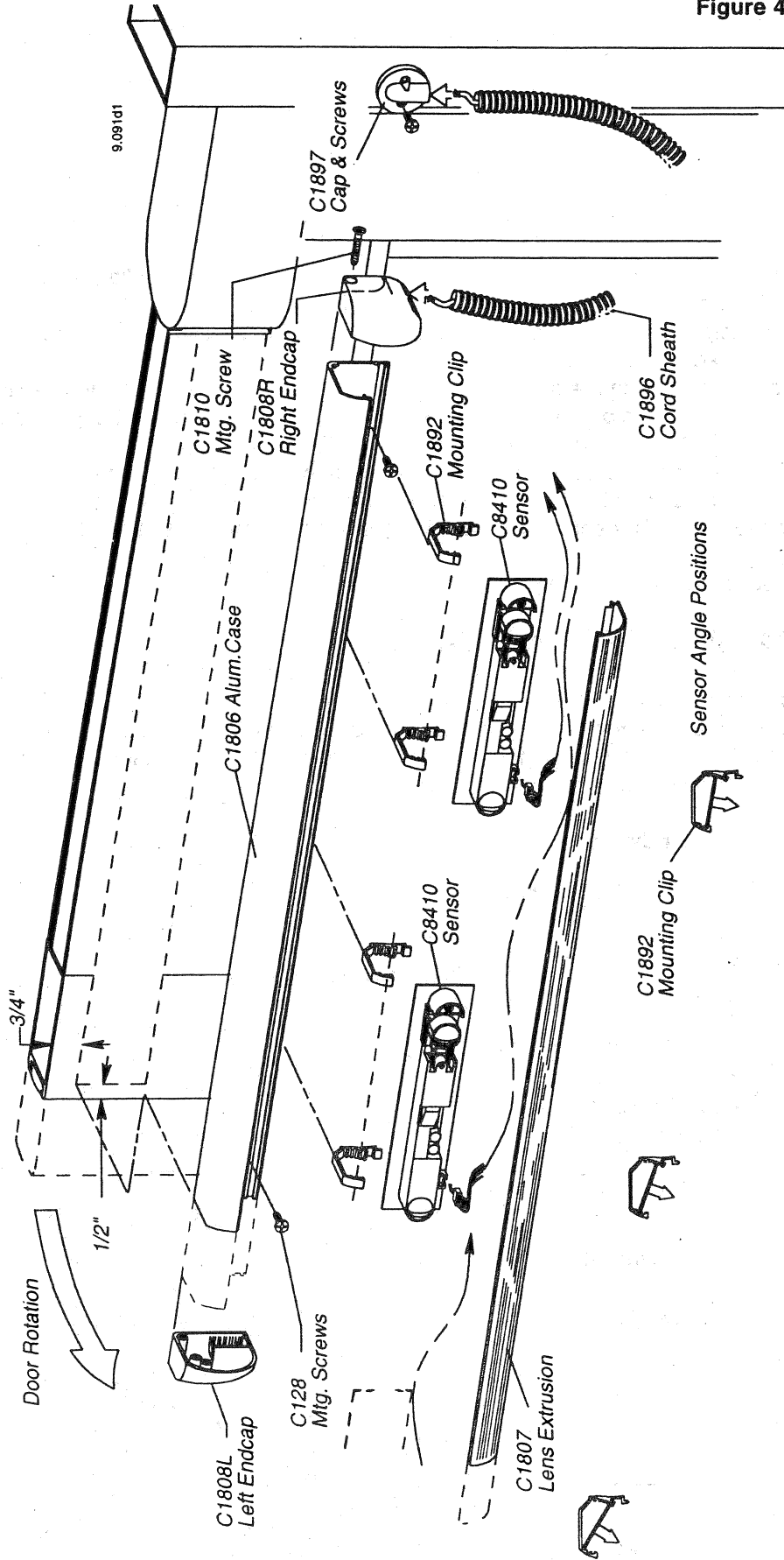


Figure 43 - VistaStop Installation

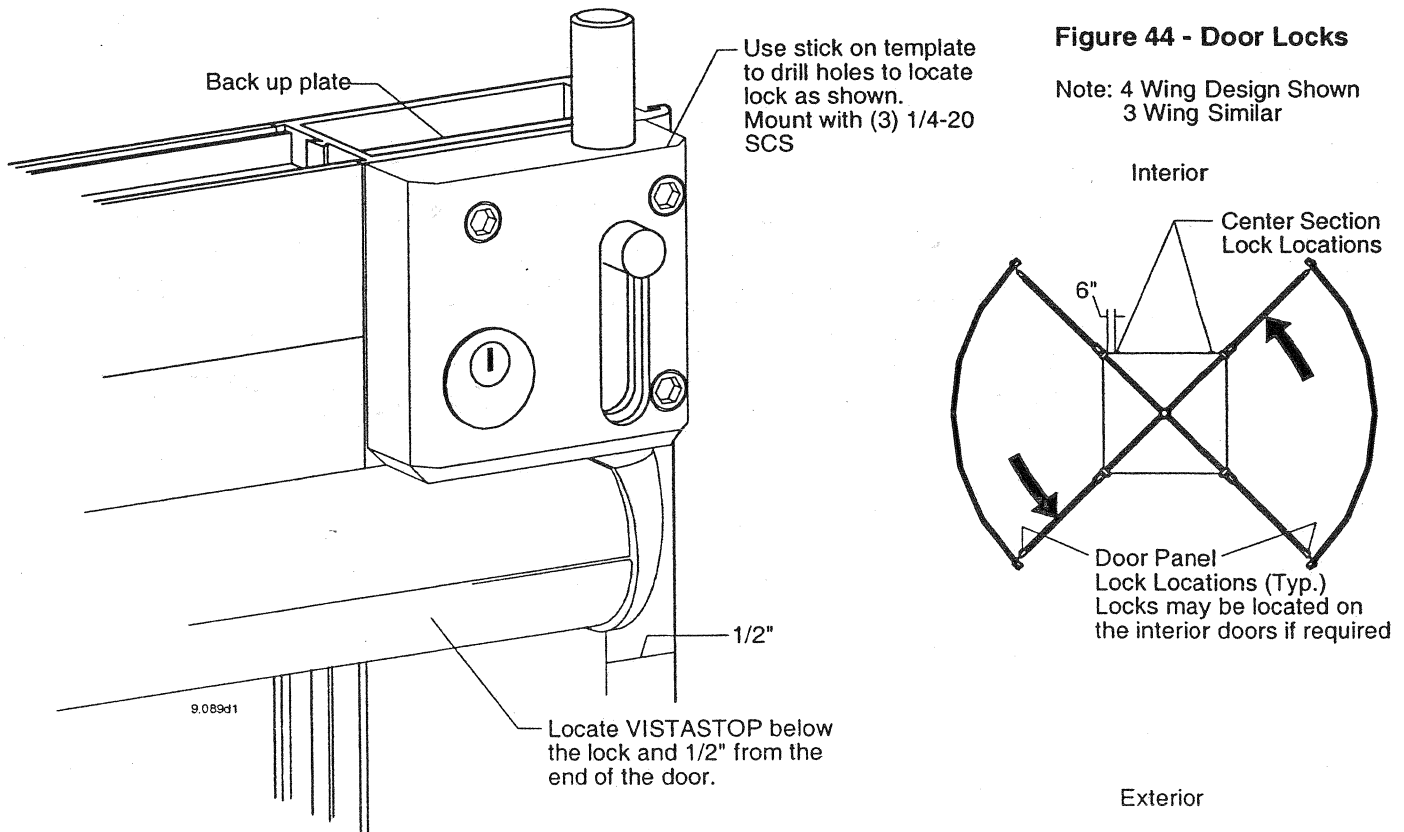


1. Determine Direction of Door Rotation.
2. Attach C1806 Aluminum Case to Top Rail of Door Leaf with C128 #6-1/2" RHSMs. Be Sure that Unit Installation Does Not Interfere with Breakout Function of Door Leaf. SCAN AREA TO PROVIDE HEEL PROTECTION OF TRAFFIC
3. Mount & Adjust Optics in C1892 Mounting Clips for Required Detection Scan Coverage. Sensors May Need to be Individually Angled.
4. Perform Electrical Connections Per Wiring Diagram (attached).
5. Check and Adjust for Proper Operation.

- C. Splice the black and white wires of the motor lace to the red and black wires of the motor. If the door runs backwards reverse the leads (Figure 42).
- D. Use attached square key to couple of shafts of the motor and gear train. (Figure 42) Secure the motor to the gear train flange with four 3/8" (9.5) - 16 (4.5) x 1 1/4" (32) bolts, flat and lock washers (Figure 42, Detail `A`).
- E. Mount the C9879 micro-switch to the standoffs with two 6 (5) -32 (132) x 7/8" (22) socket cap screws. Mount the micro-switch and standoffs to the C9359 bracket using the 6 (5) - 32 (132) x 1/2" (12) pan head machine screws. Secure the switch assembly to the gear train using the black M12 x 22 HH (Metric) bolt (Figure 42, Detail `A`).
- F. Position the doors (Figure 42, Detail `C`) and place a C9636 quarter point indicator on the quarter point disk (Figure 42, Detail `B`).
- G. Check the action of the C9879 micro switch against the indicator. The C9879 micro switch should click just before it gets to the top of the screw head on the C9636 indicator (Figure 42, Detail `B`).
- H. Rotate the door 90 degrees (4 wing design) and install the next quarter point indicator. Repeat until all are in place. Consult the owner for location of locks.

## 25. DOOR LOCKS AND STRIKES

- A. Four surface mounted locks are required to provide security: two locks on the center section and two on the door panels. See Figure 44 for placements of locks.
- B. If lock cylinders are to be changed, do so before mounting lock as lock must be removed to access the set screw that holds the cylinder in place. If no change is required, mount the lock.
- C. Position the door as shown in fig. 44. Locate the core locks approximately 6" from the edge of the core. Use the stick on template to locate and drill and tap the holes (#7 drill, 1/4" tap). Mount the lock with the 1/4" SCS provided. Extend the lock bolt and mark the position on the ceiling. Rotate the core enough to drill the 1 1/8" dia. holes at the center of the mark. Install the strike with silicone and the 1" push nut.
- D. Lock the core locks and install the wing locks as shown in fig. 44. Extend the lock bolts and mark the ceiling and install the keepers as described above.



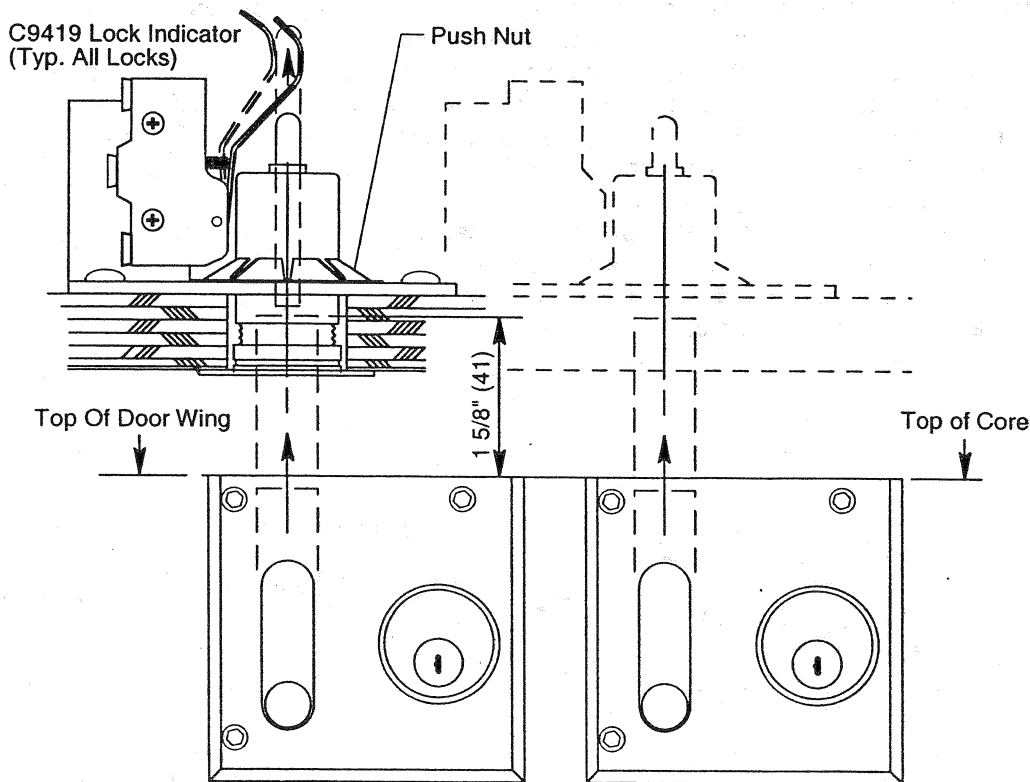
## 26. MICRO-SWITCH MOUNTING

- A. Mount the C9479 micro switch to the C9690 mounting bracket (Figure 45). Place the bracket on top of the shim and secure to the 3/4" plywood ceiling. Adjust the arm of the switch so that the switch is activated when bolt is in lock position.

## 27. ELECTRICIAN'S WIRING INFORMATION

**ELECTRICAL CONNECTIONS:** Please find the wiring diagram located in the control box, taped to the cover. 120 VAC 20Amp dedicated service should be supplied to the four-plex receptacles provided in the canopy of the revolving door. The C9810-1 control box is provided with a grounded 120 VAC plug for quick connection. Protection for the system is provided by a 2 amp thermal circuit breaker in the control. It will serve as an on/off switch (push on/push off). It is desirable to have dedicated service (the revolver being the only thing connected to the breaker at the main panel) because other equipment can cause interference with the on board microprocessor in the C9810-1 control.

Figure 45 - Surface Locks and Microswitch



NOTE: ( 4 ) LOCKS SENT LOOSE. LOCKS TO BE SURFACE MOUNTED AT TOP OF CORE & DOOR WING. (TEMPLATE PROVIDED). HARDWARE BY HORTON, CYLINDERS BY OTHERS.

## 28. GENERAL OPERATING INFORMATION

- A. The C9810-1 control has a governor built in which prevents pushing the Grand Revolver faster than 6.5 RPM. The C9810-1 control has been factory set at 2.6 RPM in the normal speed and 1.3 RPM in the handicap mode. These speeds can be changed by changing the transformer taps.
- B. The small 5 position dip switch located on the main circuit board has the following effects on the operation of the door (Factory settings are all in the off position).
  - 1. This switch is not used in the Grand Revolver.
  - 2. Time delay in handicap speed: off 20 seconds/ on 50 seconds. This switch determines how long the door will run in handicap speed after the handicap button is pushed. All other inputs to return to normal speed are ignored when this timer is running.
  - 3. Time delay in normal speed: off-10 seconds/on-3 seconds.
  - 4. This switch is not used in the grand revolver.
  - 5. Door action after safety stop: off- automatic restart/on manual push to restart. With this switch on, you will have to push the door after any safety stop to restart it.

## 29. WIRING MOTOR AND QUARTER POINT SWITCHES

- A. Loosen the screws on the vacant strain relief on the C9810-1 control box and insert the free end of the motor lace/flexible conduit (that was placed on the motor in section 24,C) into that connector until 1/4" (6) of conduit is inside the control box. Tighten the strain relief screws until the conduit is secure.
- B. Plug the connectors of the motor lace into the motor leads inside the control box. The wires go black to black and white to white.
- C. Connect the micro-switch wiring lace, (the yellow wire and the white wire with the ring terminals on them) to the N.O. and Com. terminals of the C9879 quarter point micro-switch (installed in Section 24, E). Connect the other end of this to terminals #1 and #2 on the side of the C9810-1 control box.
- D. It is recommended that the door be put into operation at this time and before any accessories are added. Check for proper operation.
- E. Turn the NORML and HNDCP 3 - turn potentiometers fully counterclockwise. NOTE: Door will not safety stop (Minimum sensitivity).
- F. Push the breaker on (the white ring will disappear). The red LED should blink 4 times, and then go out. The door should run slowly in a counter clockwise direction until it comes to a quarter point indicator (installed in Section 24). At this time the yellow LED should come on and the door should stop in the position shown in Figure 42, C. This may require some adjustment. It is helpful to remember that a 1/4 movement at the quarter point disk is equal to about 3 1/2" at the strike rail of the door.
- G. Gently push the door; it should run in slow speed for 1/2 second, then increase to normal speed and run for 3 or 10 seconds depending on DIP Switch #3 setting. The red LED will go out, and the door will stop at the next quarter point position.
- H. Place a jumper wire on terminal #1 of the C9810-1 control box and touch it momentarily to terminal #4. The door should run at handicap speed for 25 or 50 seconds depending on the setting of DIP Switch #2. The red LED will go out, and the door will stop at the next quarter point position  
**CAUTION! DO NOT PUT A JUMPER FROM COMMON TO #7, AS DAMAGE WILL RESULT.**

## 30. ADJUST SAFETY SENSITIVITY

- A. Repeat Section 29, H and use the timed period to adjust the handicap safety sensitivity using the small three turn pot marked HNDC. Turn the screw clockwise while applying back pressure to the door. Be sure to wait until the override timer has expired (door has reached full handicap speed) before attempting to safety stop. When sufficient back pressure is applied, the shunt relay will operate and the door will stop for approximately five seconds. This step can be repeated as necessary, keeping in mind that one might have to push the door to restart after three consecutive safety stops.
- B. Connect a jumper wire from terminal #4 to terminal #5 of the C9810-1 control. This will hold the door in the operating condition so that the normal safety sensitivity may be adjusted.
- C. Adjust the normal safety sensitivity using the small three turn pot marked NORML. Turn the screw clockwise while applying back pressure to the door. Be sure to wait until the override timer has expired (the door has reached full normal speed) before attempting to safety stop. When sufficient back pressure is applied, the shunt relay will operate and the door will stop for approximately five seconds. This step can be repeated as necessary, keeping in mind that one might have to push the door to restart after three consecutive safety stops.

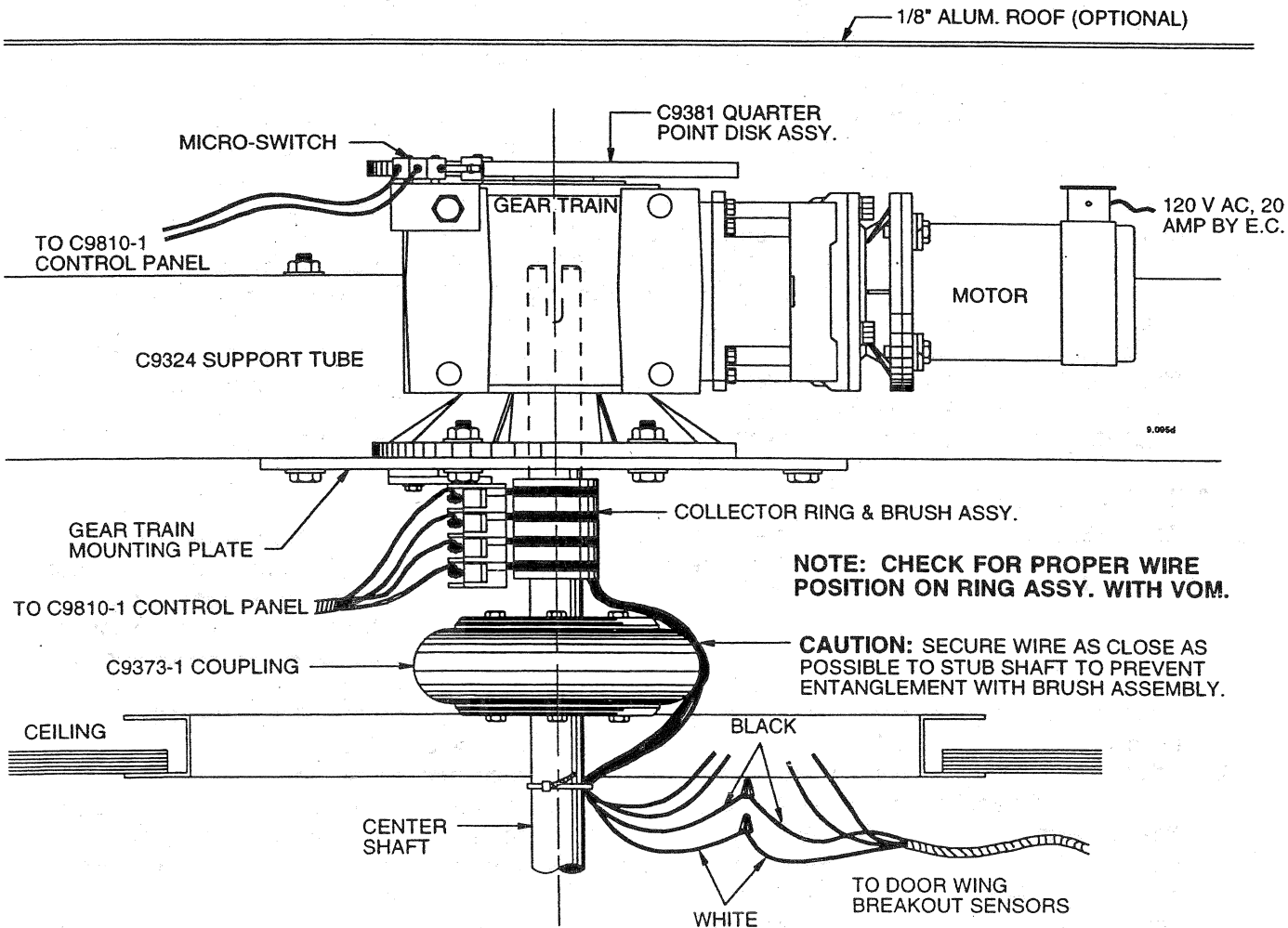
### 31. WIRING BREAKOUT SWITCHES

- A. Test for continuity between black and red wires on the magnetic switches that were installed in Section 22. The circuit should be open (infinite Ohm reading) with the door at rest. Hold the center section in place, and deflect the door to the rear approximately 6 - 8 inches. The circuit should now be closed (Ohm reading close to 0). Deflect the door forward approximately 18-20 inches. The circuit should now be closed (Ohm reading close to 0). This circuit provides for a safety stop if the door contacts a person from behind, or if the door is pushed hard enough to endanger anyone.
- B. Wires to the breakout switches should be attached to the ring assembly: the white wire from the collector to the red wire from the switch and black wire from the collector to the black wire from switch.
- C. Connect the white wire from the brush assembly (Section 8) to the common bus (terminal #8) of the core connector on the C9810-1 control box. Connect the black wire from the brush assembly to terminal #5 of the C9810-1 control box core input

### 32. WIRING LOCK MONITOR SWITCHES

- A. Connect the common of all four lock monitor switches to terminal #4. Connect the normally open contacts of all four lock monitor switches to terminal #2 of the C9810-1 control. (See wiring diagram - Fig.##)

Figure 46 - Wiring Switches



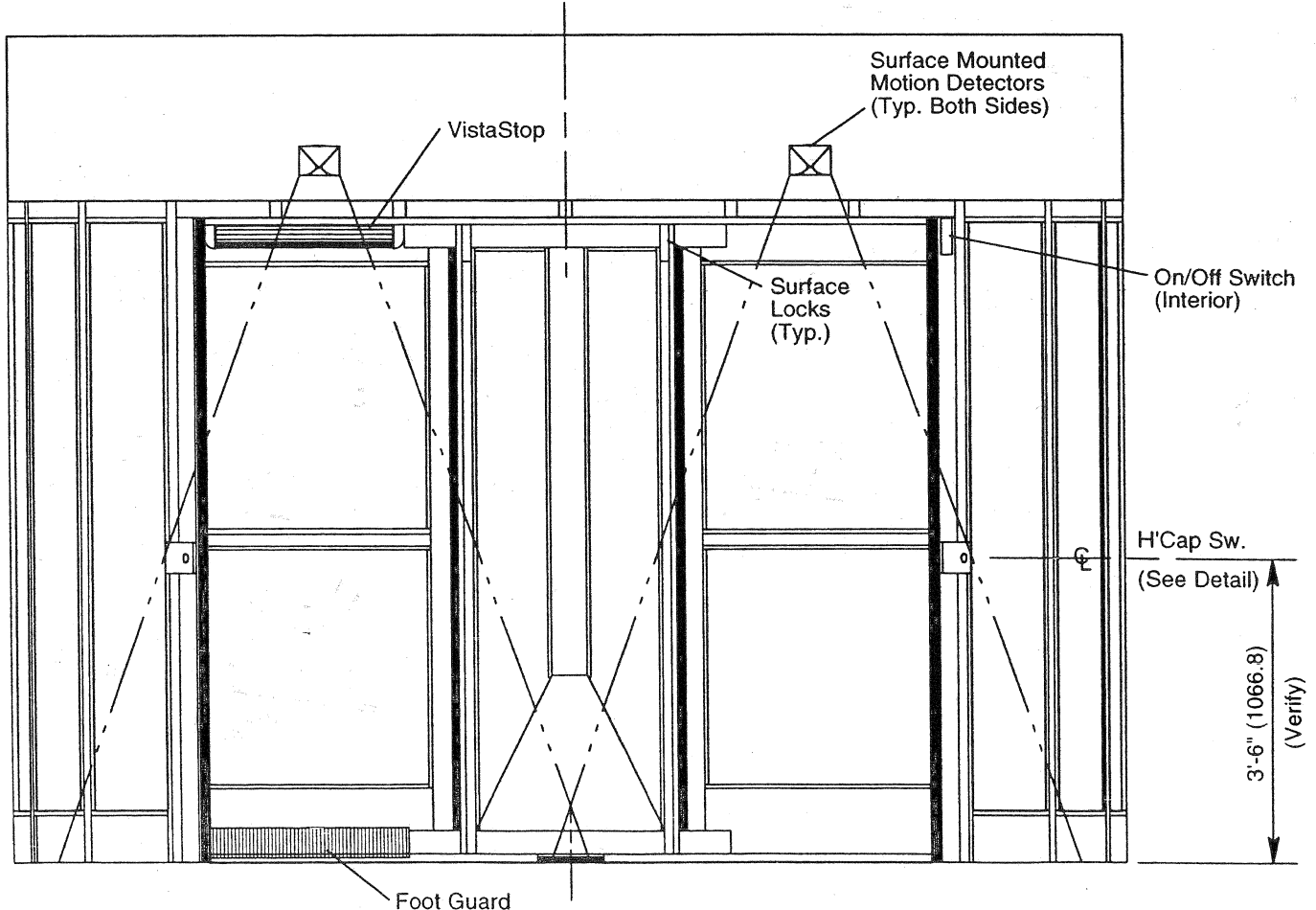
### 33. INSTALLING AND WIRING ON/OFF SWITCH

- A. Consult with owner and determine the best location for the on/off rocker switch. We recommend the area shown in Figure 47. It will be necessary to make a hole at least 1 inch (25) in diameter to provide clearance for the nut on the back of the rocker switch. Feed the wire on the back of the switch through the mounting plate and then fasten the switch to the plate with the nut provided. The white dot on the rocker should point to OFF.
- B. Feed the wire all the way into the 1"(25) inch hole and fit the switch and mounting plate flush with the canopy panel. Mark the mounting holes and drill a #31 or 3/32" (2) pilot hole. Mount the switch with the two #6 (5.2)x 1/2" (12) flat head sheet metal screws provided.
- C. Connect the white wire to terminal #6 and connect the black wire to terminal #13 of the C9810-1 Control. This needs to be a N.C. input.

### 34. INSTALLING HANDICAP BUTTON

- A. Mount the switch box as shown in Figures 31 & 32 with #10 (4.9) pan head sheet metal screws.
- B. Drill a 1/4" hole (6) or larger through the switch box and into the C325-1 vertical rail so that the wire can be run into the hollow part of the tube.
- C. Run the gray four wire conductor (C1300) through the box and up the C325-1 tube to the C9810-1 control box. At the handicap switch box, connect the wire terminals (provided) to the black and white conductors of the C1300 and push the terminals onto the common and normally open terminals of the handicap micro switch (Figure 48).
- D. Fasten the face plate to the box with the flat head machine screws.
- E. Connect the white wire to terminal #11 and the black wire to terminal #9 or #10 on the C9810-1 control.
- F. Wire the cable from the C1720-2 voice annunciator to the C9810-1 control. Connect the two speakers in parallel.
- G. Press test button and adjust pitch and volume. Control will talk when handicap button is pressed and will talk again 8 seconds later.

Figure 47 - Elevation of 4 Wing Grand Revolving Door





### 35. WIRING SAFETY NOSING

- A. Splice all four of the white wires from the safety nosing together and connect them to terminal #1 of the larger strip in the C9810-1 control. Splice all four black wires together and connect them to terminal #3 on the C9810-1 control.

### 36. INSTALLING AND WIRING C1801 MOTION DETECTORS

- A. Mount the 4 motion detectors as shown in Figure 47 with the #6 round head sheet metal screws. Do not mount higher than 8' (2438). Drill through the canopy panel and run the four conductor cable (provided) from each motion detector to the C9810-1 control. Connect the white wire to terminal #3 (COM) and jump to terminal #2 (c) on the motion detector and to terminal #8 on the C9810-1 control. Connect the red wires to terminal #4 (NO) of the motion detector and terminal #5 (Int.) or #6 (Ext.) of the C9810-1 control.
- B. Set range and time delay for your application. Time delay will be in addition to time delay selected by DIP Switch #3. Make sure that you allow time to get completely through the door.
- C. See general instructions packed with motion detectors for set-up and adjustment of motion detection zones. (Figure 49)

Figure 48 - C9616 Handicap Switch

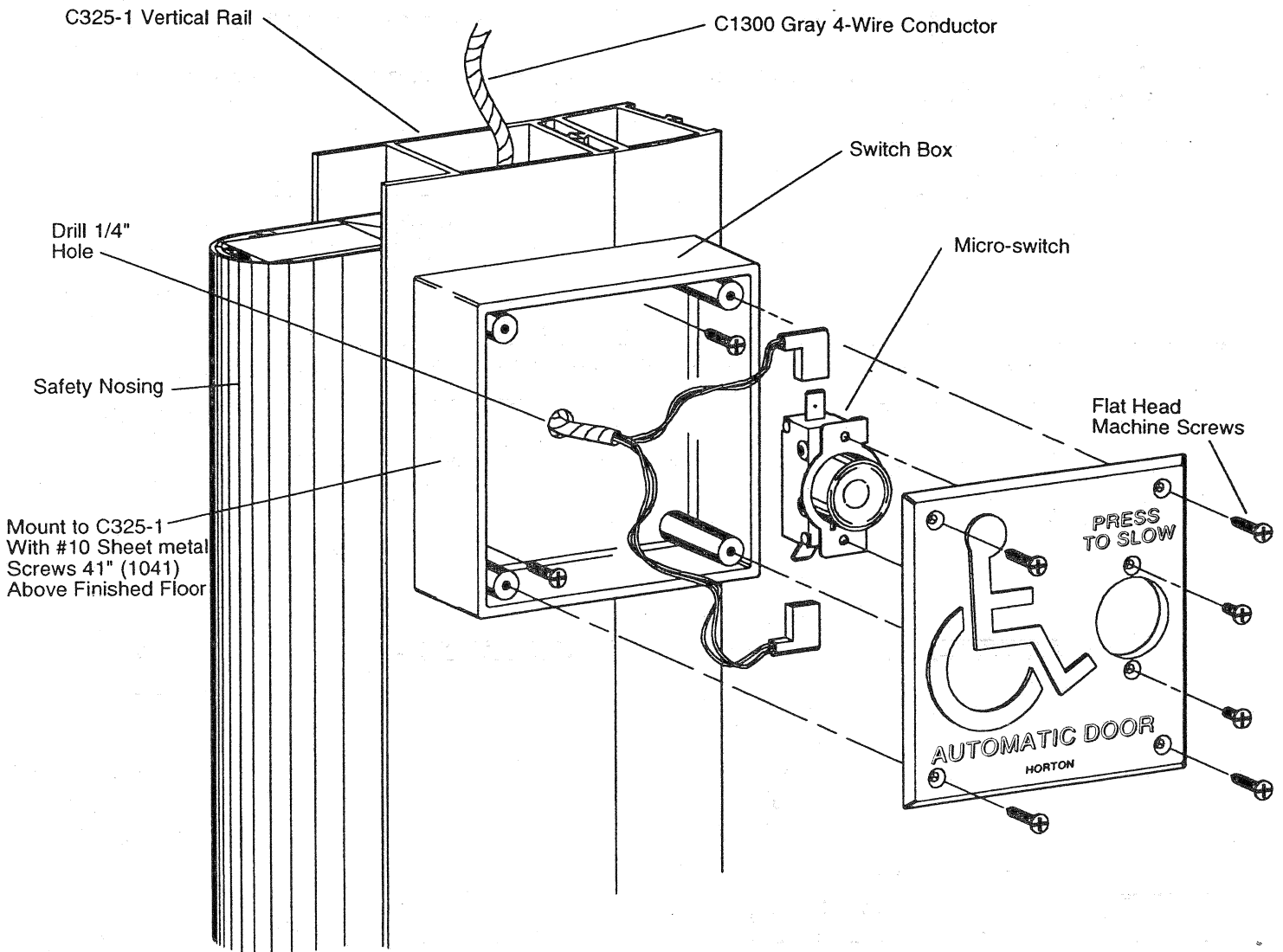
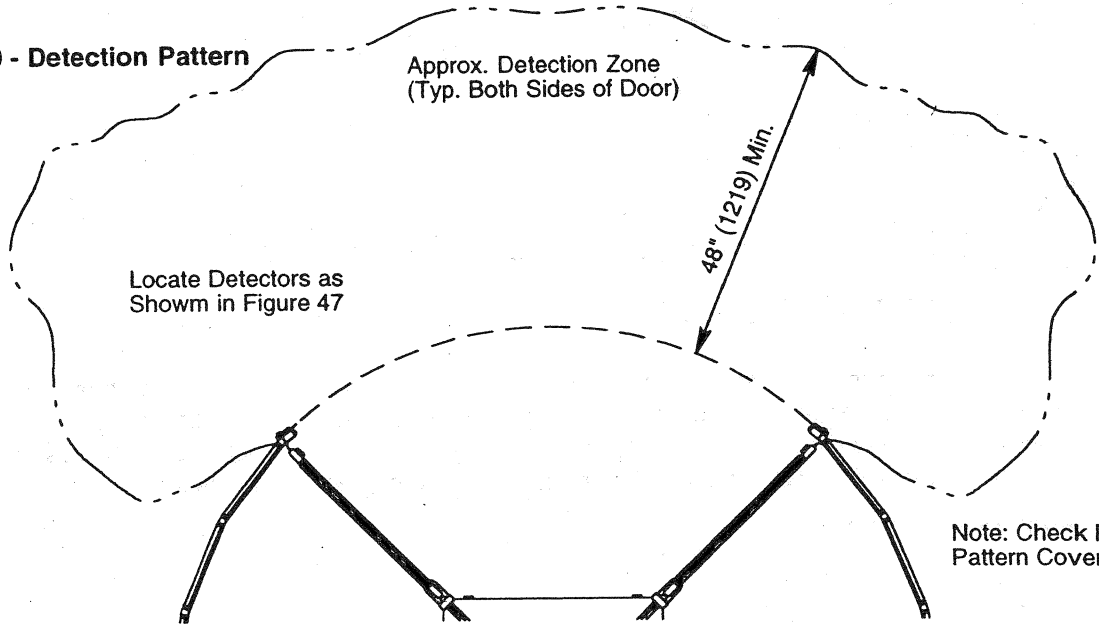


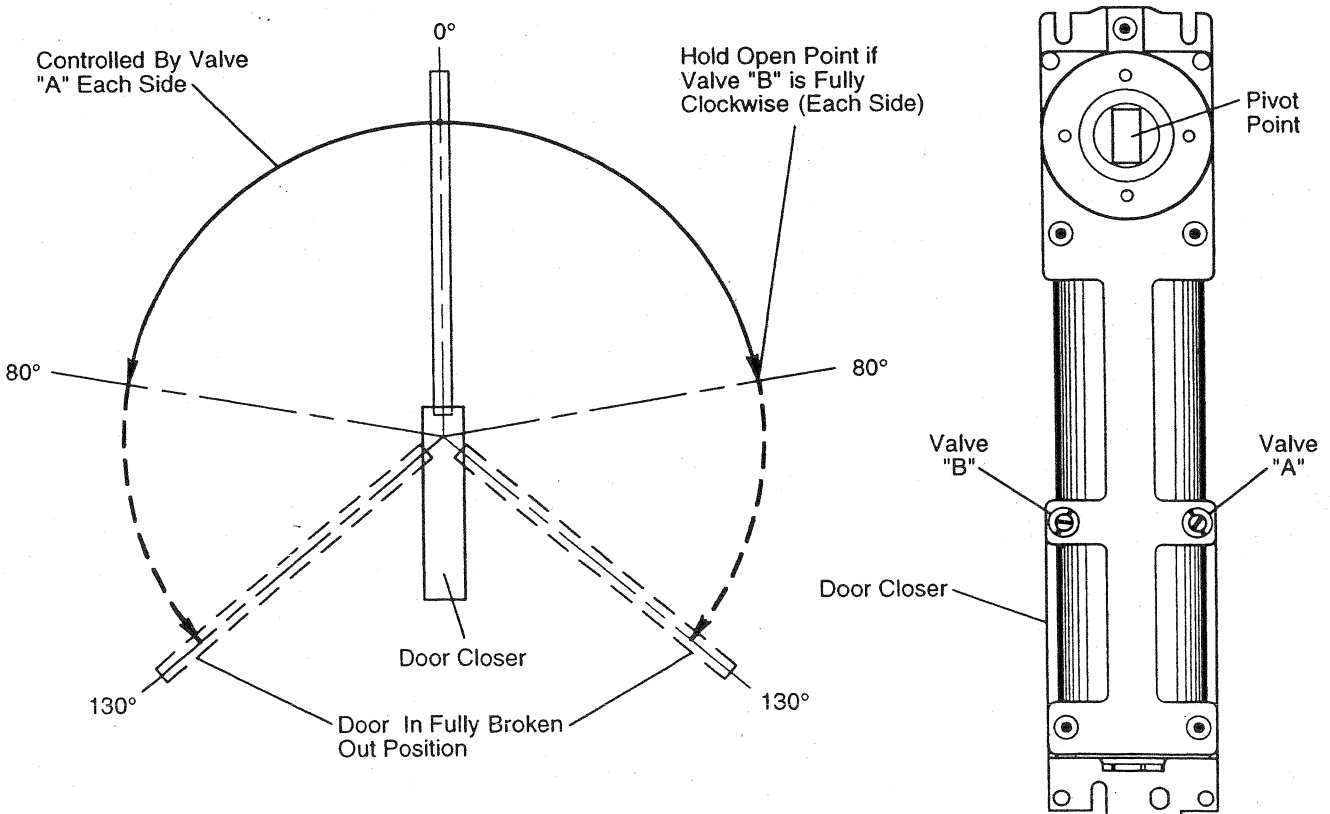
Figure 49 - Detection Pattern



### 37. ADJUSTING DOUBLE ACTING CLOSER

- A. To adjust the closing speed of the door panels, break the door out to about 80 degrees and allow it to return to its original position. Adjust valve `A` clockwise to decrease the closing speed From 130 degrees to 80 degrees or it can be used as a hold open feature if turned fully clockwise (Figure 50).

Figure 50 - Door Closer Adjustments



### 38. INSTALLING SEGMENTED DRUM GLAZING

- A. Glazing stops are the snap-in type and can be installed using hand pressure. If inner stop is the narrow profile type, as commonly used for 1" (25) glazing, install this glass stop first at all four sides. Position nylon setting blocks to support glass. Carefully set glass in place. Install short outer stops first, then the longer outer stops next. If adjacent wall construction prevents glazing from exterior, the procedure can be reversed with added difficulty. A rubber mallet may be used to gently tap glass stops into place. Use caution if laminated glass is used as it can easily be cracked (Figure 51).

### 39. INSTALLING DOOR PANEL GLAZING

- A. Door panel glass is easiest to install before panels are hung. Lay door panels flat across two sawhorses and install glass stops on side of door panel facing down. Then install glass panels. Complete installation by installing glass stops on side of door panel facing up. See figure 52 for cross-section view of door panel with glazing. Check door wing for squareness and block if necessary.

Figure 51 - Segmented Drum Section

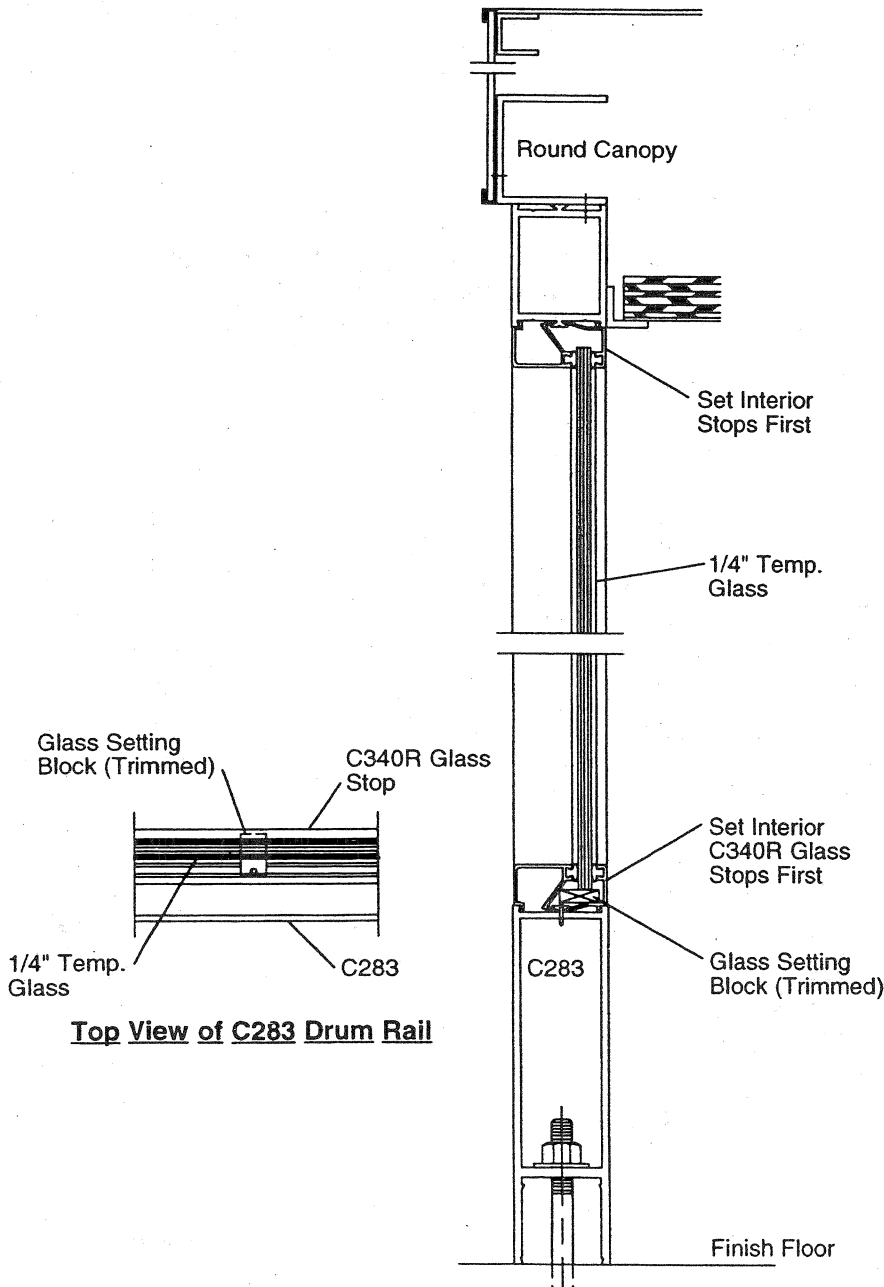
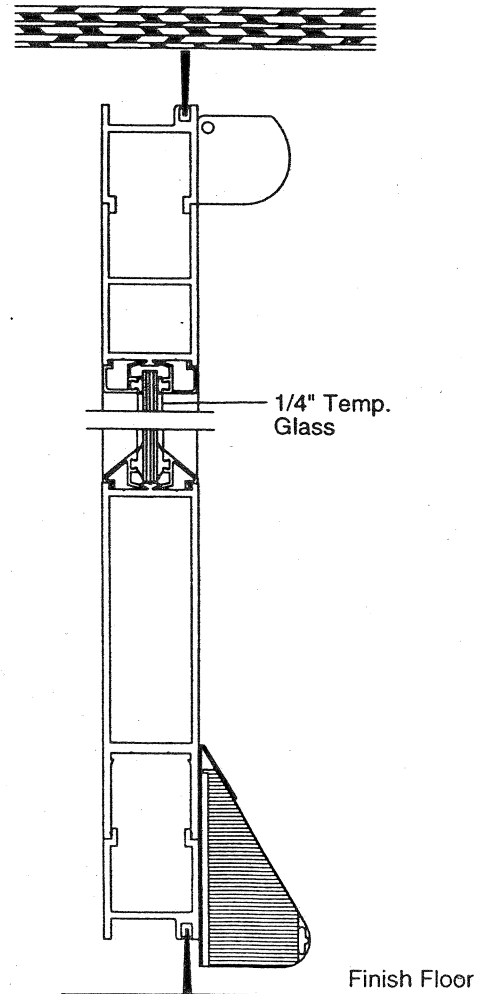


Figure 52 - Door Panel Section



## 40. CURVED GLASS INSTALLATION

### Special Tools:

- 1 or 2 special glass cups for curved glass, CR Laurence #W6450
- Beam Compass to check radius of door & glass
- Windex window cleaner

**Note:** A minimum of 2 people is suggested for successfully installing curved glass.

- A. Check door framework for accuracy. Use a beam compass or layout lines to check door radius. refer to figure 53 for floor plan of a typical 4-wing round Grand Revolver.
- B. Lay glass crate down with arrows pointing up and carefully remove crate top.
- C. Check glass dimensions vs. cut sheet.

**Note:** All cut sheet dimensions are outside radius and arc length. Check glass height against frame opening.

- D. The exterior half of the bottom rail should be removed (match mark during removal). Check all setting edges on bottom rail, top rail, throat rails and center rails for straightness and correct with appropriate tool if necessary (Figures 54 & 55).
- E. Horton recommends removing the brass alignment pins to avoid glass breakage during installation (Figure 55). Mark pin locations before removal.

Figure 53 - Floor Plan of 4-Wing Round Grand Revolving Door

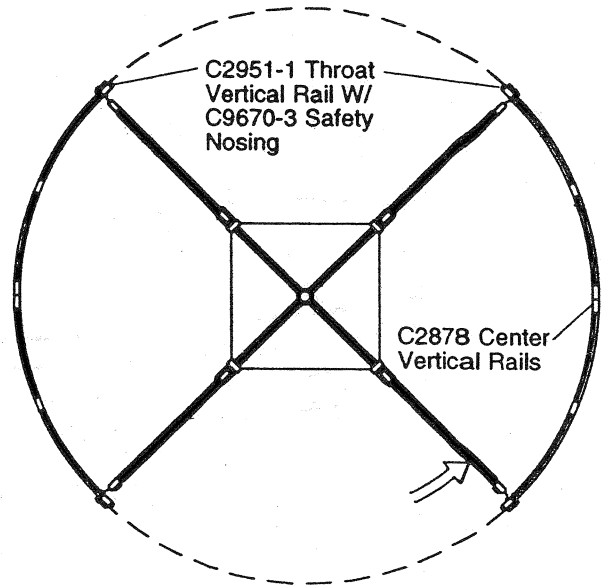


Figure 54 - Horizontal Section at Throat Rail

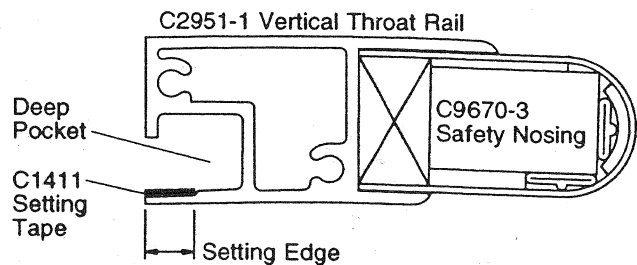


Figure 55 - Inner Bottom Rail

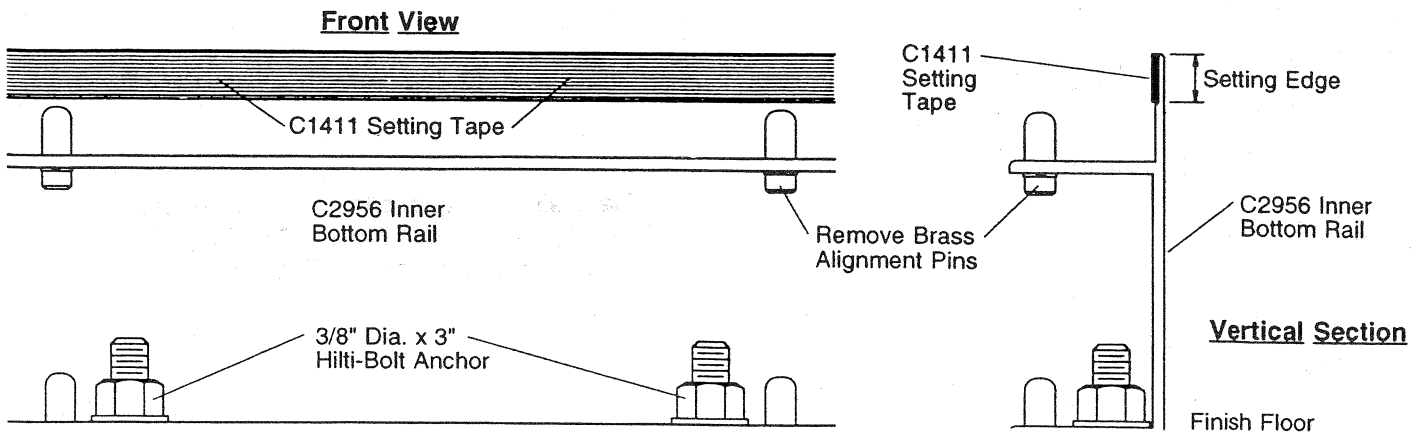


Figure 56 - Bottom View of Enclosure Wall

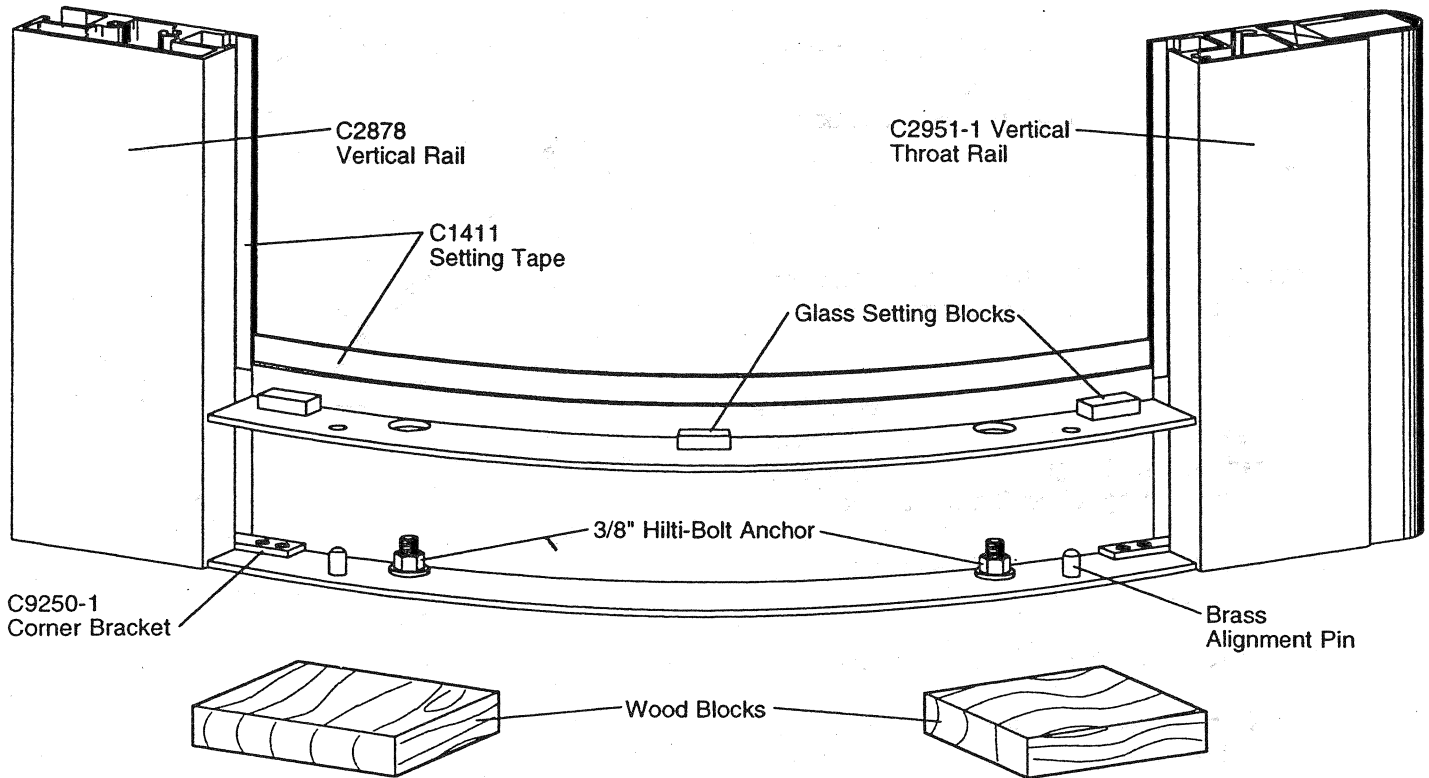
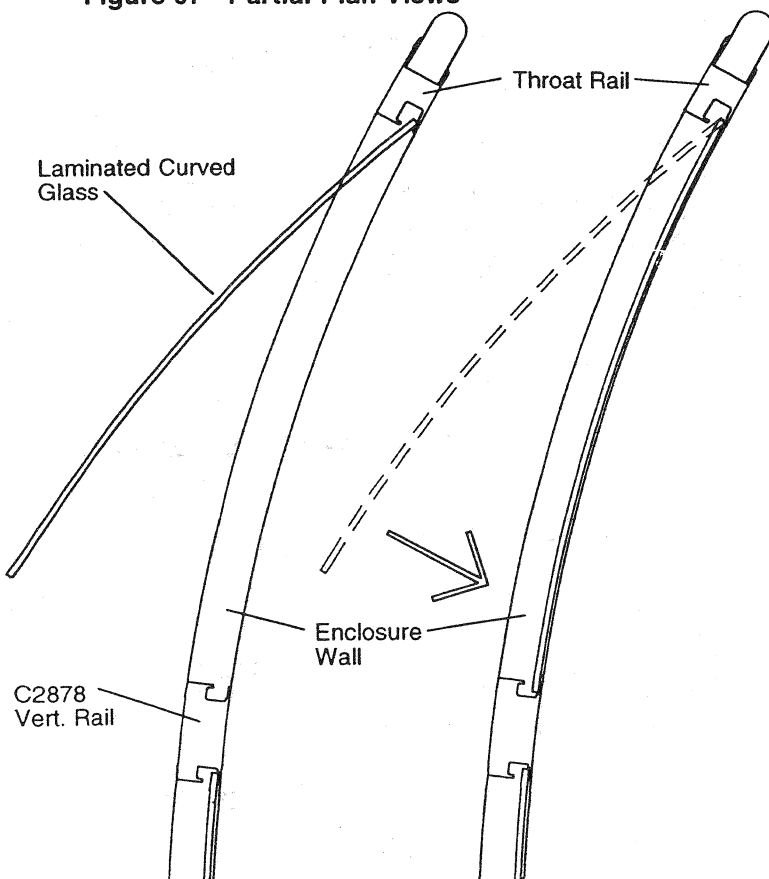


Figure 57 - Partial Plan Views



- F. Install C1411 setting tape on all four edges of enclosure wall (Figure 56). Remove backing paper and spray with Windex. **Note:** You must apply Windex to the tape. The Windex allows the glass to slide during installation. It will dry in approx. 1-2 hours.
- G. Lay 3 or 4 glass setting blocks on the bottom rail. Set wood blocks on the floor near the enclosure wall (Figure 56). Attach the cups to the glass and position near the wall on top of wood blocks.
- H. Lift the glass over the glass setting blocks and begin working the the vertical glass edge into the throat rail as far as possible (Figure 57).
- I. Next, slide the opposite vertical glass edge into the vertical rail (Figure 57). The glass overlap should be equal - Typical 3/8" (10).

- J. Remove the excess glass setting blocks leaving only one 6" (152) from each corner. Do not use more than 2 sets of glass setting blocks per glass section. Lift the glass up and begin working the top glass edge into the ceiling support bracket (Figure 58).
- K. Next, have your partner place the required number of glass setting blocks directly on top of each of the two existing glass setting blocks (Figure 59). **Note:** It is important that the glass top and bottom "overlap" on the extrusion setting edge be equal. Shim with glass setting blocks on the bottom rail to obtain this correct glass height.
- L. Cut several scrap pieces of glazing rubber approximately 3" (76) long and gently insert them at several locations between the glass and both the vertical and throat rails to temporarily hold the glass in place (Figure 59).  
**CAUTION: DO NOT FORCE IN.**
- M. Reinstall the alignment pins and the exterior half of the bottom rail. **Caution: Do not** use excessive force to install. This can cause the laminated glass to crack. Wet glaze with silicone caulking. Refer to **Figure 60** for a "before" and "after" Vertical Section.
- N. Finally, glaze the remaining seven sides of the revolver by repeating steps A-N for each side.

Figure 58 - Vertical Section

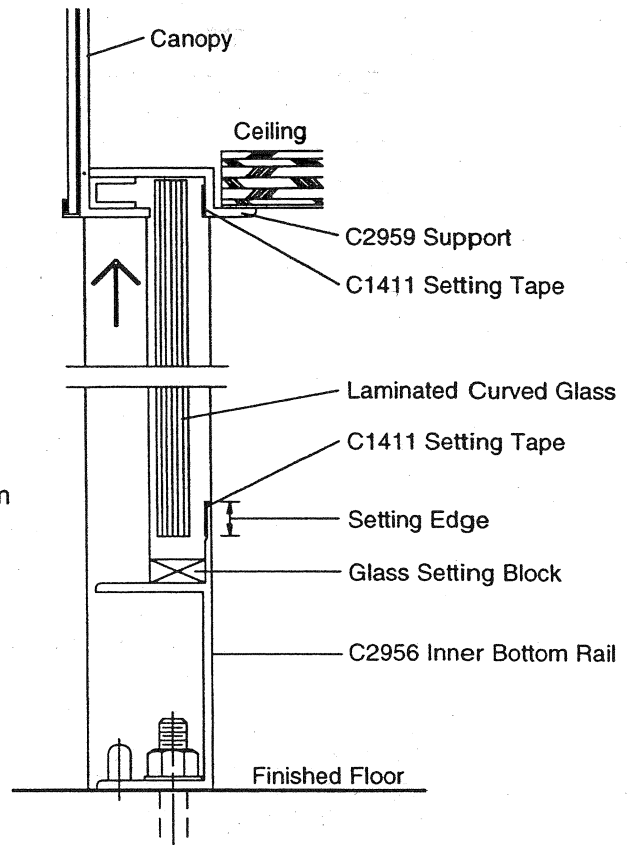


Figure 59 - Bottom View of Enclosure Wall

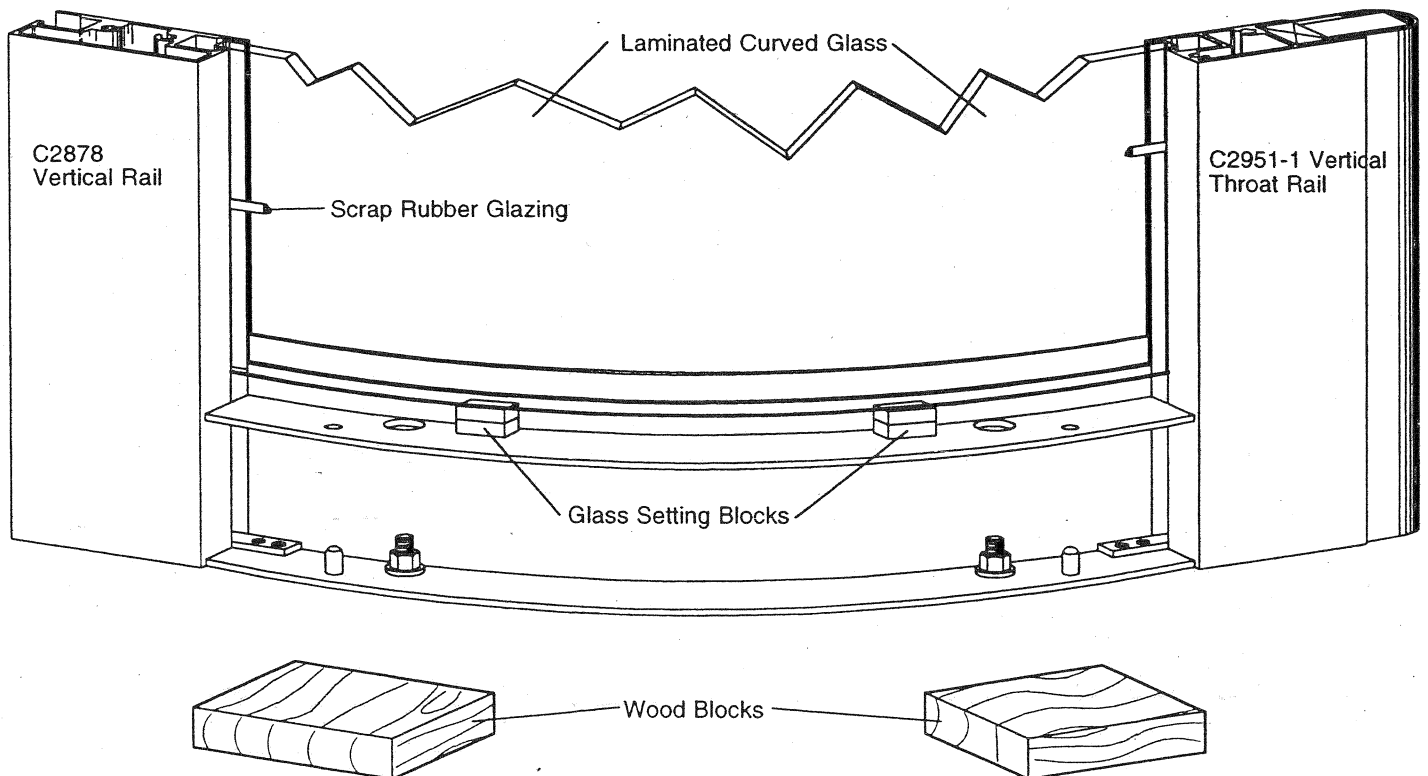
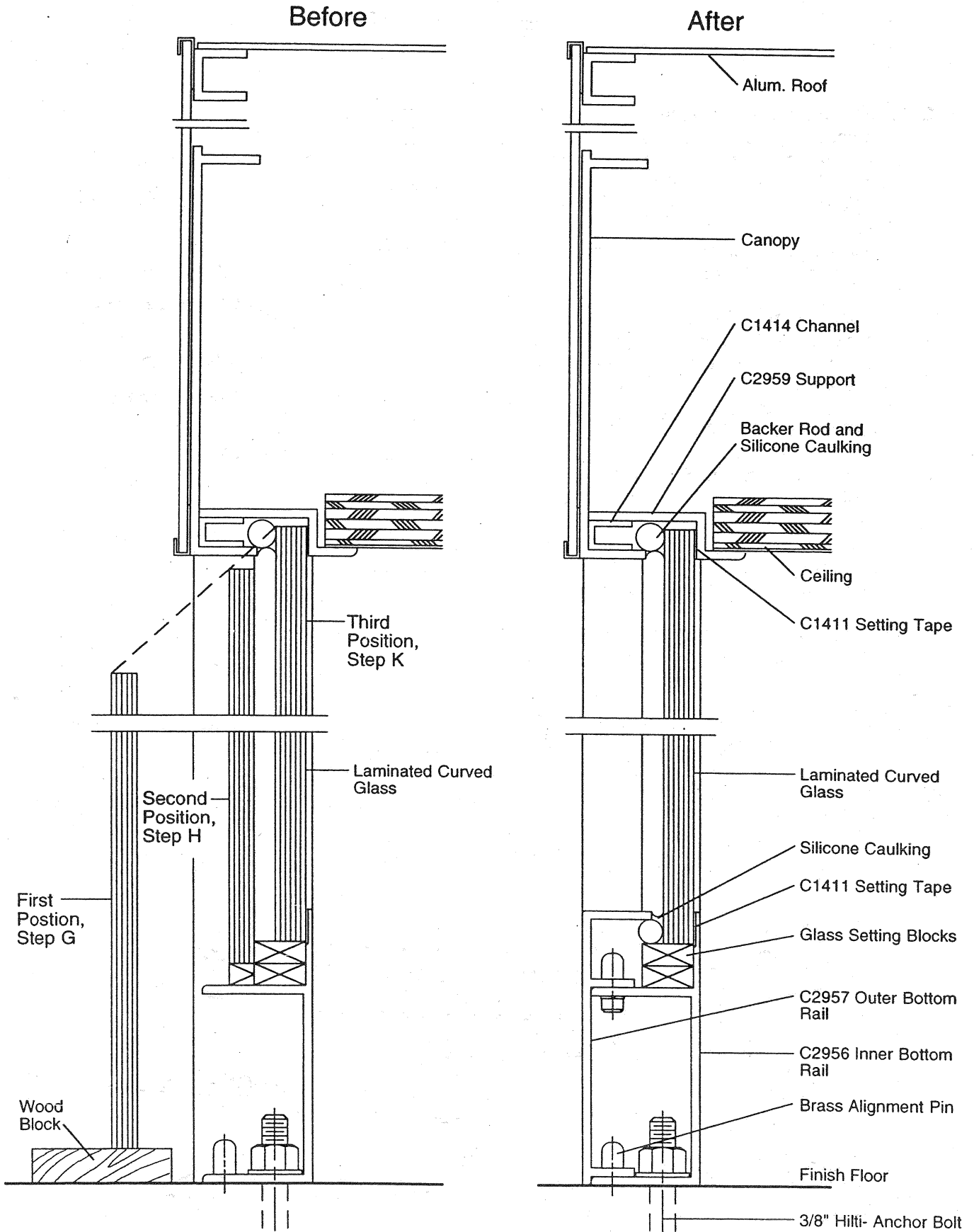


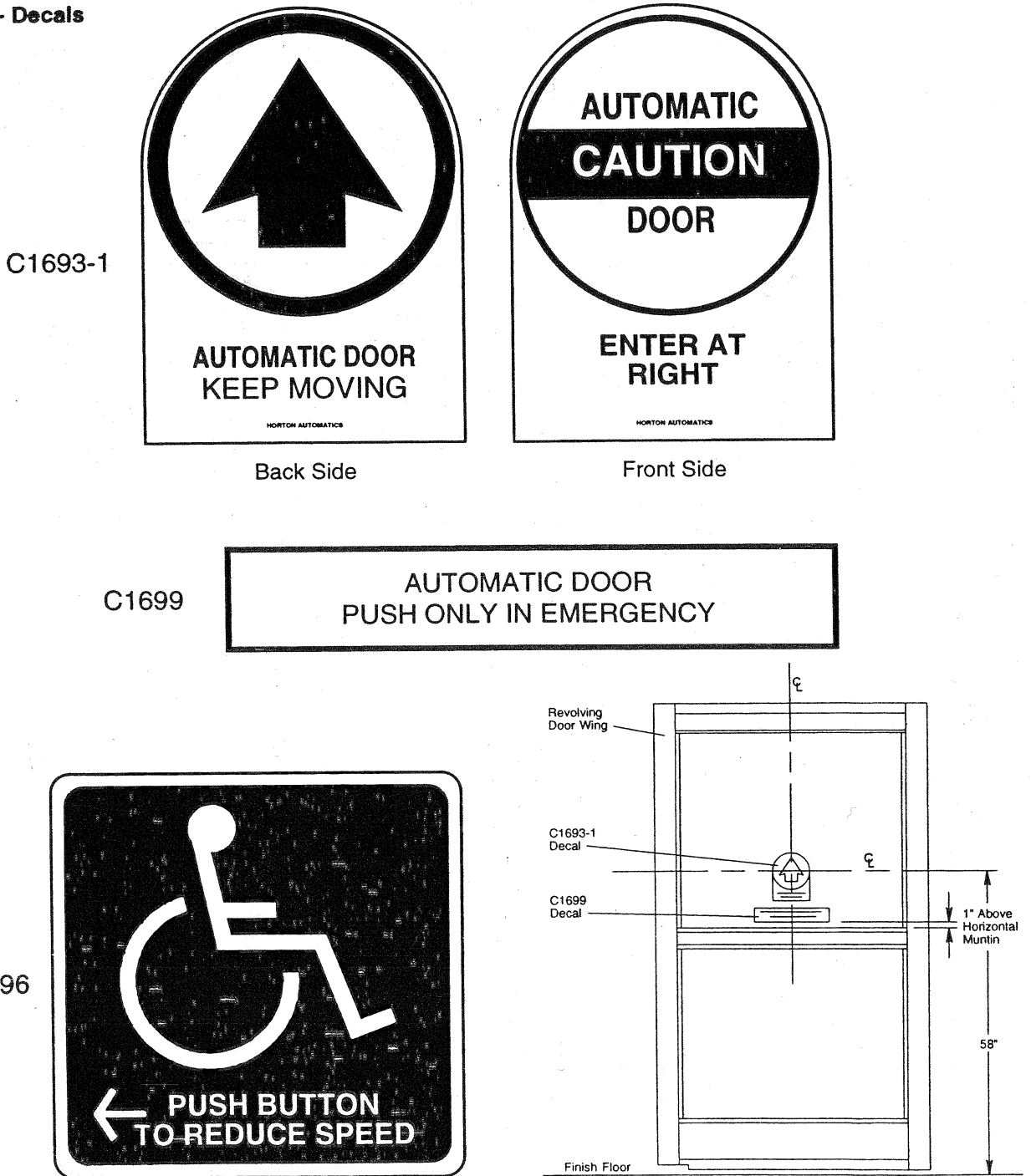
Figure 60 - Vertical Sections



## 41. DECAL APPLICATION

- A. See figure 61 for illustrations of decals. Apply C1693-1 "Automatic Door - Keep Moving" decal on each door wing, centered with center line of decal 58" (1473) above finished floor. Apply C1699 "Automatic Door - Push Only In Emergency" rectangular decal on each door wing, centered, with bottom of decal 1" (25) above horizontal door muntin. Apply (2) 8" (203) square C1696 "Handicap - Left" decals at drum glass next to throat entrance/exit. Arrow of decal should be in line and pointing to the C9616 Handicap push button (C1696-1 Similar). Apply the C1690 "Daily Safety Check" decal (not shown) on throat vertical post at 60" (1524) above floor.

Figure 61 - Decals



DOOR WING ELEVATION  
SHOWING DECAL LOCATION





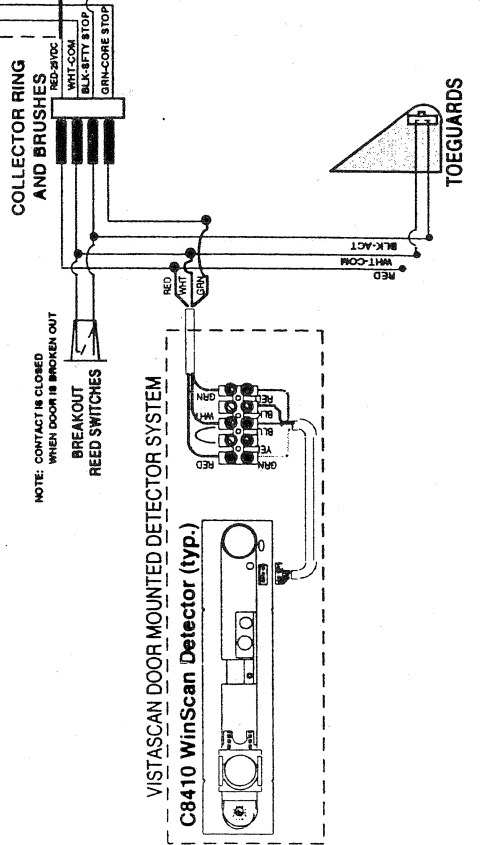
4242 Baldwin Boulevard  
 Corpus Christi, Texas USA 78405  
 (800)531-3111 FAX: (800)531-3108  
 (361)888-5591 FAX: (361)888-6510  
 AUTOMATICS Internet - http://www.hortondoors.com

**C9810-1 GRAND CONTROL**  
 120 VAC  
 WINCAN RETROFIT TO REPLACE STOPGUARD  
 DRAWING #10000.3  
 08JAN99

**7 SEGMENT DISPLAY FUNCTION CODES**

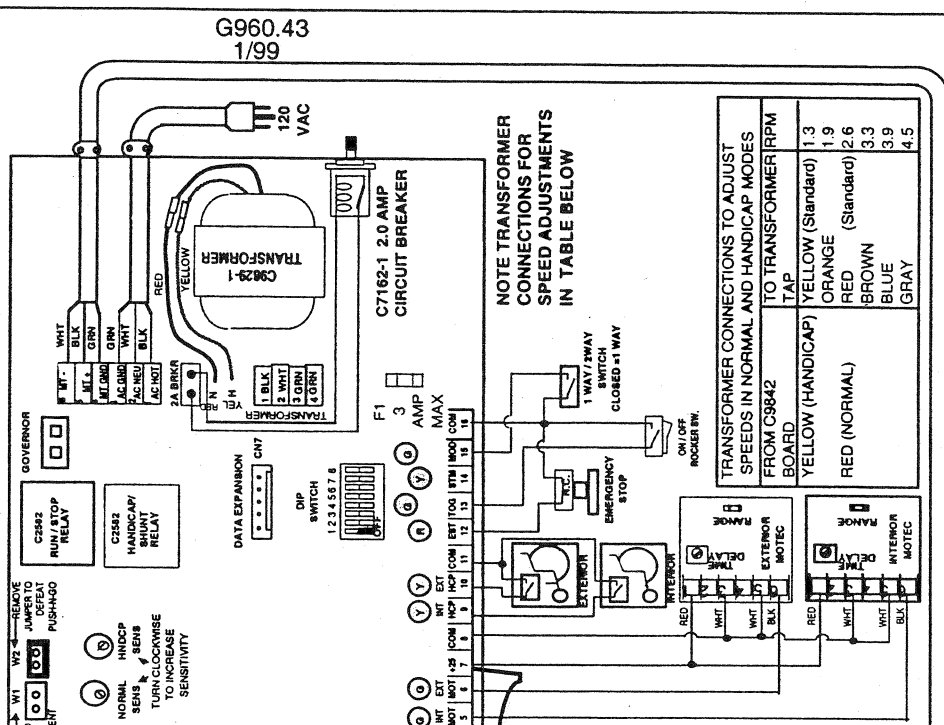
- 1 Executive loop - waiting for motec, handicap switch, or push to begin operation
- 2 This code appears for 1/4 second before the door starts running.
- 3 If the actuation was caused by Push - n - go activity
- 4 Override delay active (decimal point is on during minimum wait).
- 5 Normal speed run (decimal point is on if Entry Guard is enabled).
- 6 Waiting for door to slow down before quarterpoint (decimal point is on during minimum wait)
- 7 Seeking quarterpoint (Decimal point is on if switch was tripped when door began to quarterpoint.
- 8 Switch must clear and decimal go off before door will quarterpoint
- 9 This code is displayed while the control is shunting the door at the end of the normal quarterpoint sequence.
- 0 Handicap (reduced) speed mode
- 1 Door slowed due to entry Guard trip. Will resume normal speed when entry guard detector clears, or at next quarterpoint.
- 2 Door stopped due to motor Overcurrent.
- 3 Door slowed due to core device trip (Dip 1 off). Scanners have been set to short range, and if another core trip detected will go to 4 and door will be stopped.
- 4 Door slowed due to BEA Trip (DIP 1 on)
- 5 (winking) door is idling due to excessive safety stops in timed / push mode Push to restart.
- 6 This code is displayed for 1/4 second just before door "upshifts" back to normal speed if recycle was caused by Low current.
- 7 Door stopped due to safety nosing trip.
- 8 Door stopped due to Core device trip.
- 9 Door stopped due Emergency switch activation.

\*Notice! If more than one of these functions is turned on, the display will flash all of the codes in sequence.

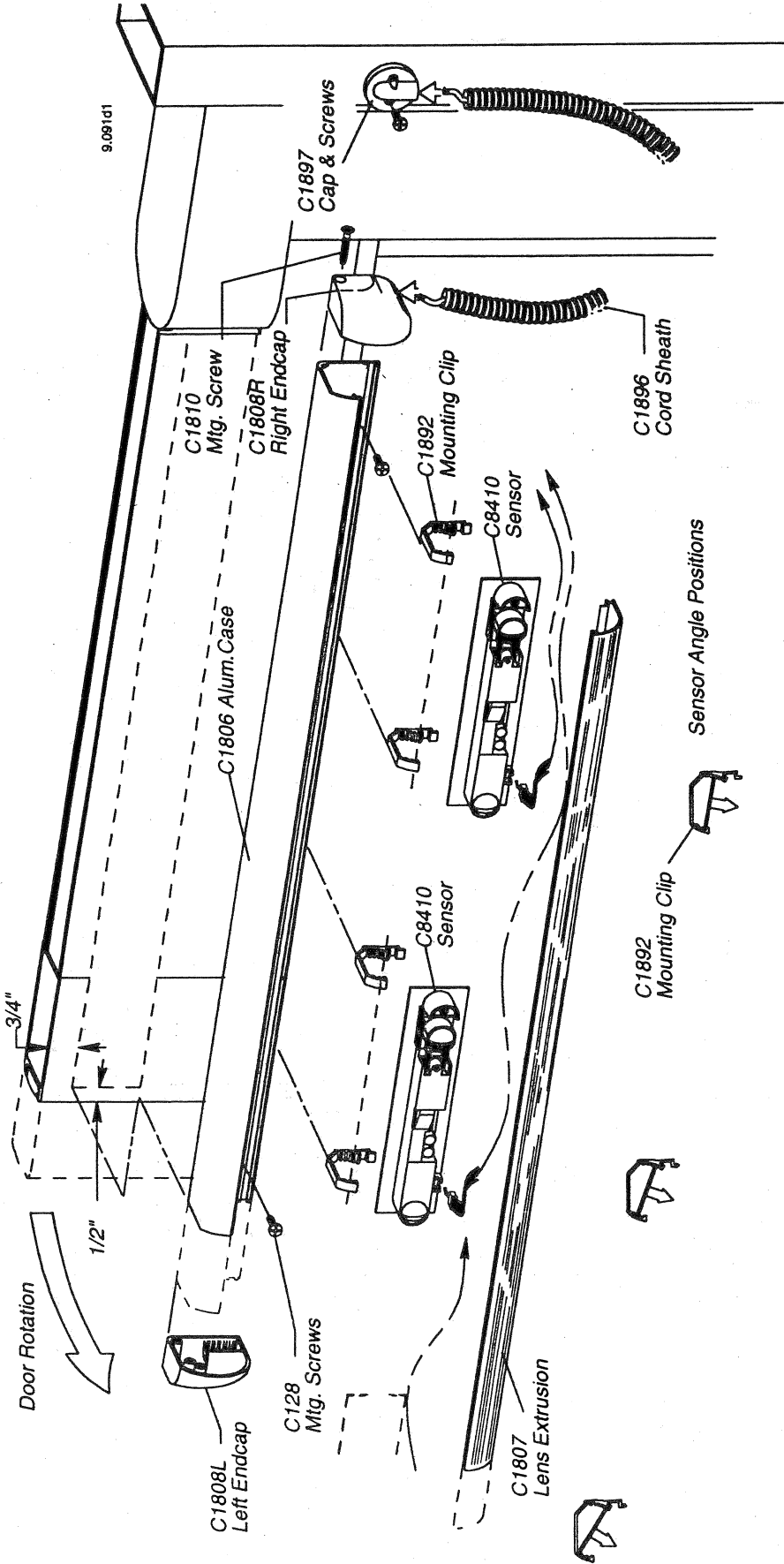


**C 9810-1 DIP SWITCH FUNCTIONS FOR VERSION 1.90 AND 2.00 SOFTWARE**

DIP 1 CORE SAFETY FUNCTION	OFF = SLOW / STOP	ON = SLOW ONLY
DIP 2 HANDICAP SPEED TIME DELAY	OFF = 25 SECONDS	ON = 50 SECONDS
DIP 3 NORMAL SPEED TIME DELAY	OFF = 3 SECONDS	ON = 10 SECONDS
DIP 4, 5 ARE USED TOGETHER TO SELECT RESTART MODE		
DIP 4	OFF	DIP 5
SAFETY IS ALWAYS TIMED	OFF	OFF
PUSH REQUIRED AFTER 3 STOPS	OFF	OFF
DOOR STARTS IMMEDIATELY	OFF	ON
DOOR ALWAYS REQUIRES PUSH	ON	ON
DIP 6 SHUNT DELAY	OFF = SHORT	ON = LONG
DIP 7 NOT USED IN THIS SOFTWARE	OFF = WHEN	ON = WHEN
DIP 8 SELECTS STOPGUARD "STEP FORWARD" SEQUENCE	DOOR SLOWS	DOOR STOPS



VistaStop (WinScan) Presence Detection (24V)



**VISTASTOP  
COMPONENTS**

1. Determine Direction of Door Rotation.
2. Attach C1806 Aluminum Case to Top Rail of Door Leaf with C128 #6-1/2" RHSMS. Be Sure that Unit Installation Does Not Interfere with Breakout Function of Door Leaf. SCAN AREA TO PROVIDE HEEL PROTECTION OF TRAFFIC
3. Mount & Adjust Optics in C1892 Mounting Clips for Required Detection Scan Coverage. Sensors May Need to be Individually Angled.
4. Perform Electrical Connections Per Wiring Diagram (attached).
5. Check and Adjust for Proper Operation.

**C9810-1 GRAND CONTROL**  
120 VAC  
SUPERSCAN RETROFIT TO REPLACE STORQUARD  
DRAWING #10000.2 30SEP96

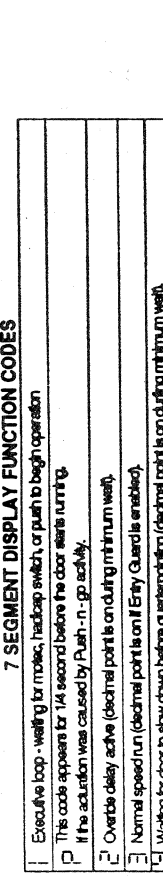
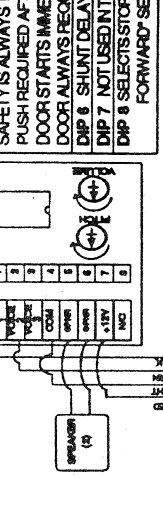
**C9810-1 GRAND CONTROL**  
120 VAC  
SUPERSCAN RETROFIT TO REPLACE STORQUARD  
DRAWING #10000.2 30SEP96

**7 SEGMENT DISPLAY FUNCTION CODES**

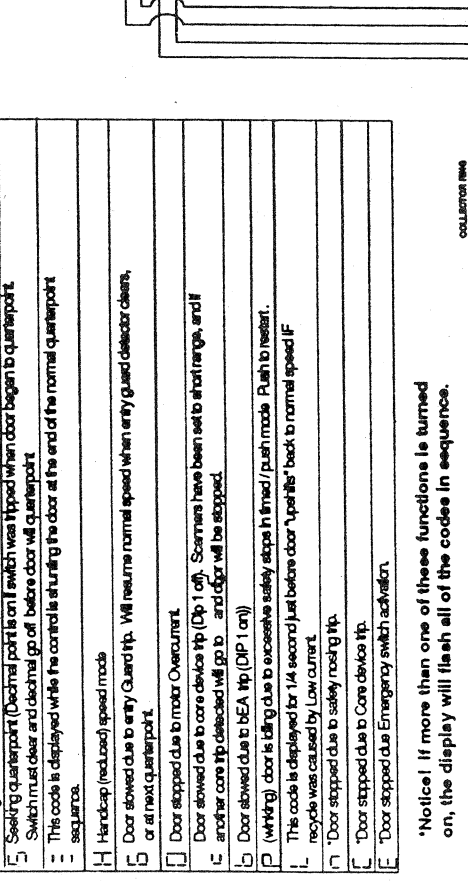
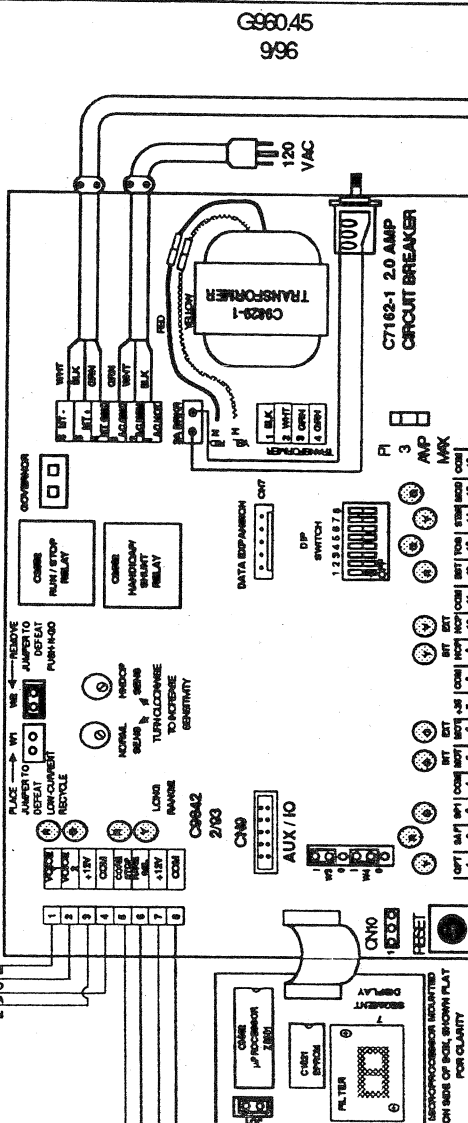
- 1 Executive loop - waiting for motor, handcap switch, or push to begin operation
- 2 This code appears for 1/4 second before the door starts turning. If the action was caused by Push-n-go, actvly.
- 3 Overlap delay active (decimal point is on during minimum wait).
- 4 Normal speed run (decimal point is on if Entry Guard is enabled).
- 5 Waiting for door to slow down before quarterpoint (decimal point is on during minimum wait).
- 6 Seeking quarterpoint (Decimal point is on if switch was tripped when door began to quarterpoint. Switch must clear and decimal go off before door will quarterpoint)
- 7 This code is displayed while the controls are shutting the door at the end of the normal quarterpoint sequence.
- 8 Handicap (red/low) speed mode
- 9 Door slowed due to entry Guard trip. Will resume normal speed when entry guard detector clears, or at next quarterpoint.
- 0 Door stopped due to motor Overcurrent.
- 1 Door slowed due to core device trip (Dip 1 off). Scanners have been set to short range, and if another core trip detected will go to 2 and door will be stopped.
- 2 Door slowed due to BEA trip (DIP 1 on)
- 3 (warning) door is falling due to excessive safety stops in timed/push mode. Push to restart.
- 4 This code is displayed for 1/4 second just before door "upsettle" back to normal speed if recycle was caused by Low current.
- 5 "Door stopped due to safety rushing trip.
- 6 "Door stopped due to Core device trip.
- 7 "Door stopped due Emergency switch activation.

**C9810-1 DIP SWITCH FUNCTIONS**  
FOR VERSION 1.90 AND 2.00 SOFTWARE

DIP 1 CORE SAFETY FUNCTION	OFF - SLOW/STOP	ON - SLOW ONLY
DIP 2 HANDCAP SPEED TIME DELAY	OFF - 2 SECONDS	ON - 50 SECONDS
DIP 3 NORMAL SPEED TIME DELAY	OFF - 3 SECONDS	ON - 10 SECONDS
DIP 4		
DIP 5 ALWAYS TIMED TO SELECT RESTART MODE	OFF	ON
DIP 6 PUSH REQUIRED AFTER 3 STOPS	ON	OFF
DIP 7 DOOR STARTS IMMEDIATELY	OFF	ON
DIP 8 DOOR ALWAYS REQUIRES PUSH	ON	OFF
DIP 9 SHUNT DELAY	OFF - SHORT	ON - LONG
DIP 10 NOT USED IN THIS SOFTWARE		
DIP 11 SELECTS STOP/GUARD STEP FORWARD SEQUENCE	OFF - WHEN DOOR SLOWS	ON - WHEN DOOR STOPS

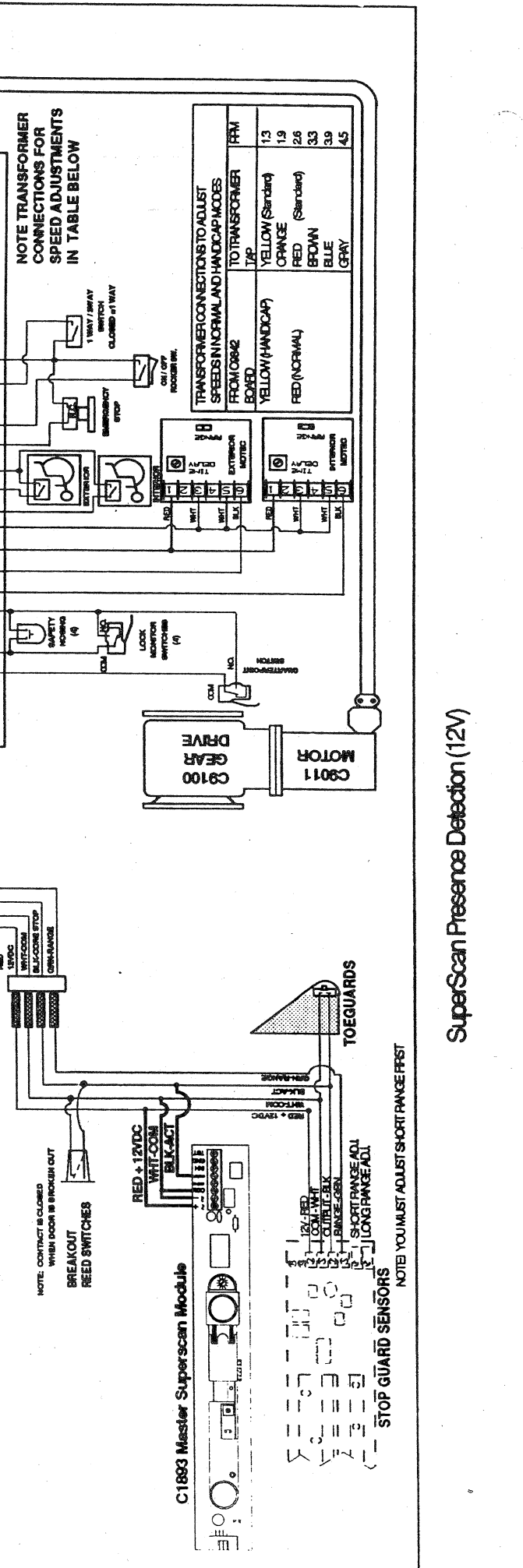


NOTE: YOU MUST ADJUST SHORT RANGE FIRST

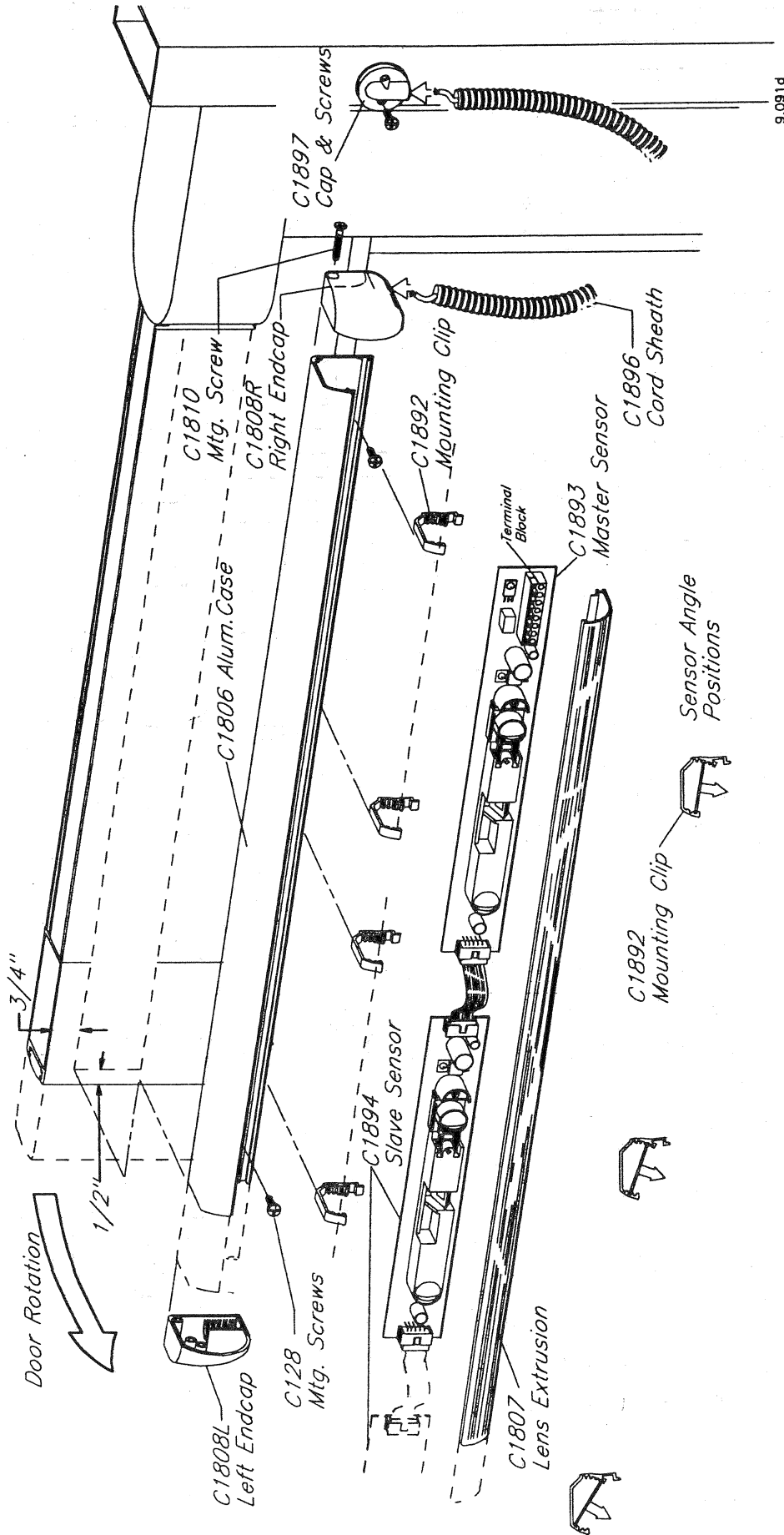


NOTE TRANSFORMER CONNECTIONS TO ADJUST SPEEDS IN NORMAL AND HANDCAP MODES

FROM C9842 BOARD	TO TRANSFORMER TAP	FRM
YELLOW (HANDCAP)	YELLOW (Standard)	1.3
	ORANGE	1.9
	RED (Standard)	2.6
	BROWN	3.3
	BLUE	3.9
	GRAY	4.5



NOTE: YOU MUST ADJUST SHORT RANGE FIRST



INSTALLATION INSTRUCTIONS  
C1878-2 BEA SUPER SCAN SAFETY STOP for REVOLVING DOORS

1. Review BEA Installation Instructions.
2. Determine Direction of Door Rotation.
3. Attach C1806 Aluminum Case to Top Rail of Door Leaf with C128 #6-1/2" RHSMS. Be Sure that Unit Installation Does Not Interfere with Breakout Function of Door Leaf. SCAN AREA TO PROVIDE HEEL PROTECTION OF TRAFFIC
4. Mount & Adjust Optics in C1892 Mounting Clips for Required Detection Scan Coverage. Master & Slave Sensors May Need to be Individually Angled.
5. Perform Electrical Connections Per Wiring Diagram (attached).
6. Check and Adjust for Proper Operation.

SUPER SCAN  
COMPONENTS

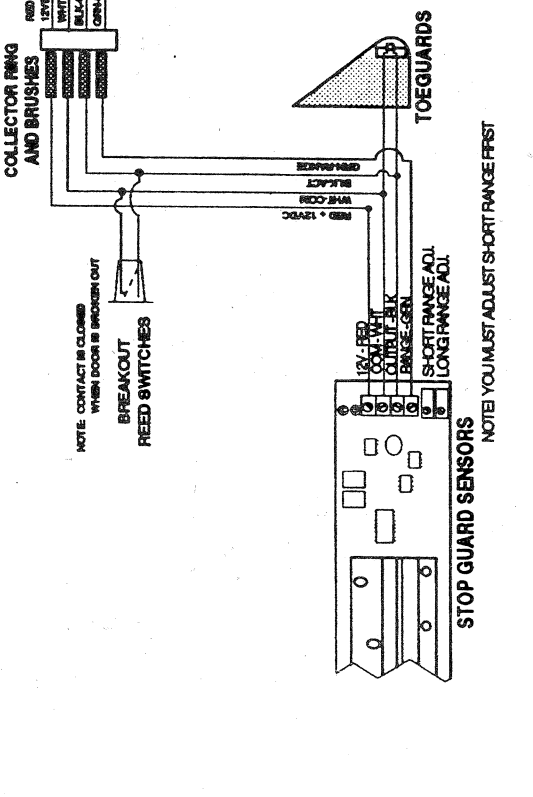
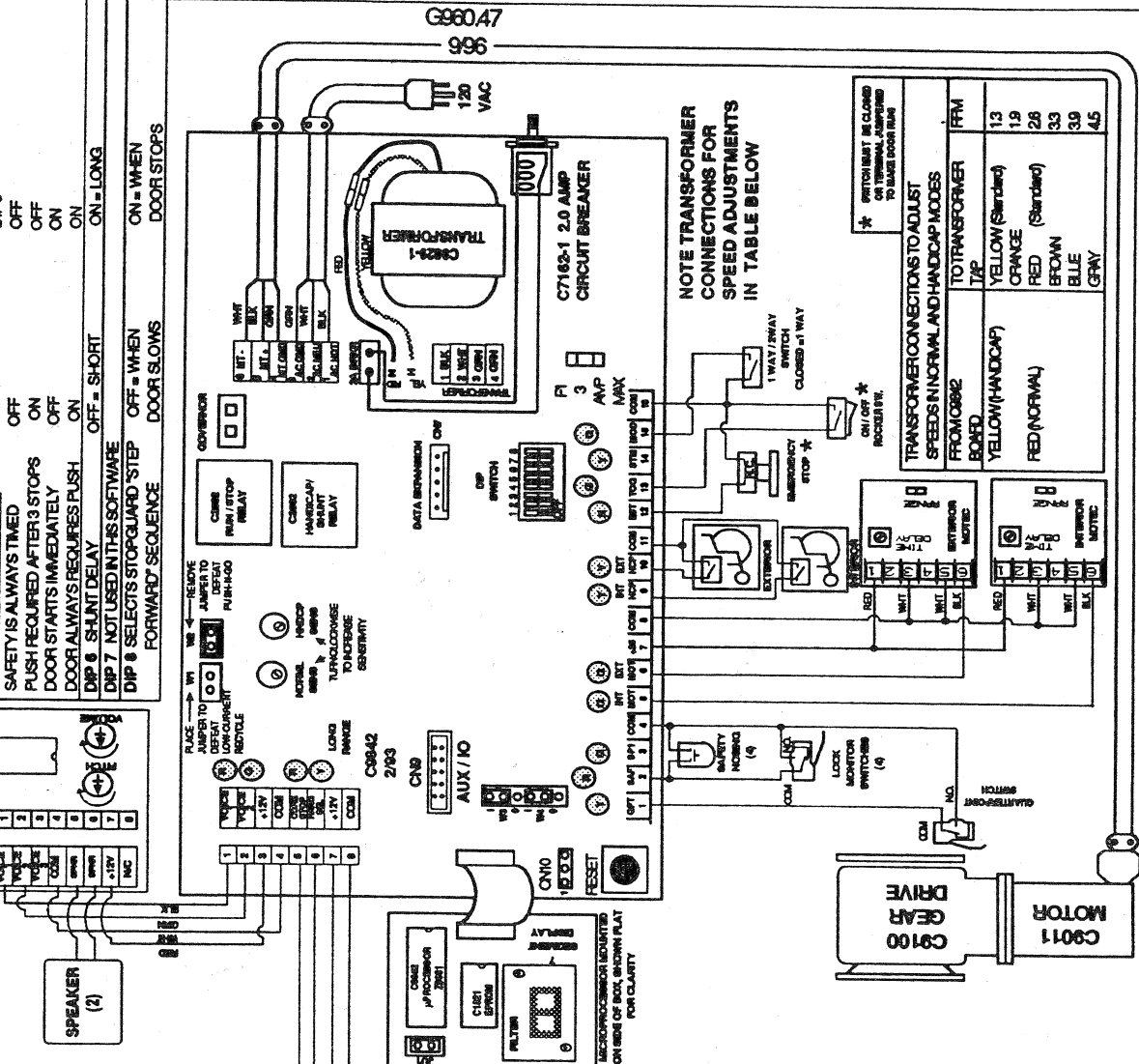
**C9810-1 GRAND CONTROL**  
120 VAC, STOPGUARD  
DRAWING #1000.1

4242 Baldwin Boulevard  
Corpus Christi, Texas USA 78405  
(800)531-3111 FAX: (800)531-3108  
(361)888-5591 FAX: (361)888-6510  
Internet: <http://www.horton.com>

**7 SEGMENT DISPLAY FUNCTION CODES**

- 1 Executive loop - waiting for motor, handcap switch, or push to begin operation
- 2 This code appears for 1/4 second before the door starts running.
- 3 If the activation was caused by Push-n-go activity.
- 4 Over-ride delay active (decimal point is on during minimum wait).
- 5 Normal speed run (decimal point is on if Entry Guard is enabled).
- 6 Waiting for door to slow down before quarterpoint (decimal point is on during minimum wait).
- 7 Seeking quarterpoint (decimal point is on if switch was tripped when door began to quarterpoint).
- 8 Switch must clear and decimal go off before door will quarterpoint.
- 9 This code is displayed while the control is turning the door at the end of the normal quarterpoint sequence.
- 10 Handicap (reduced) speed mode
- 11 Door slowed due to entry Guard trip. Will resume normal speed when entry guard detector clears, or at next quarterpoint.
- 12 Door stopped due to motor Overcurrent.
- 13 Door slowed due to core device trip (Dip 1 off). Scanners have been set to short range, and if another core trip detected will go to end of door will be stopped.
- 14 Door slowed due to BEA trip (DIP 1 on)
- 15 (Warning) door is lifting due to excessive safety stops in firm / push mode Push to restart.
- 16 This code is displayed for 1/4 second just before door "upsettle" back to normal speed if recycle was caused by Low current.
- 17 Door stopped due to safety ranging trip.
- 18 Door stopped due to Core device trip.
- 19 Door stopped due Emergency switch activation.

\*Notice! If more than one of these functions is turned on, the display will flash all of the codes in sequence.



NOTE! YOU MUST ADJUST SHORT RANGE FIRST

StopGuard Presence Detection (12V)



4242 Baldwin Boulevard  
Corpus Christi,  
Texas, U.S.A. 78405-3399  
Tel: 800-531-3111, 361-888-5591  
Fax: 800-531-3108, 361-888-6510  
Internet: <http://www.hortondoors.com>

**Horton Automatics, Ltd.**  
Unit A, Hortonwood 31  
Telford, Shropshire, England TF1-7YZ  
Tel: 01952 670169, Fax: 0192 670181  
International Tel: ++44-1952-670169  
International Fax: ++44-1952-670181

**A U T O M A T I C S    A Division of Overhead Door Corporation, A Sanwa Shutter Company**

**Form G960, 11/90, Revised 8/96, printed in U.S.A.**

Horton Automatics reserves the right to improve the product and change its specifications without notice.