

iQ Controller Installation and Operation Manual 204143

FOR SWING AND FOLD DOORS

Stanley Part Number 204143

REV A 10/2019

Copyright 2019 Stanley Access Technologies, LLC.

*Prohibition on Copying: Any unauthorized reproduction, disclosure or distribution of copies by any person of any portion of this work may be a violation of copyright law of the United States of America and other countries, could result in the awarding of statutory damages of up to \$250,000 (17 USC 504) for infringement, and may result in further civil and criminal penalties.
All rights reserved.*



All manuals can be found at
www.stanleymobileapps.com



Table of Contents

General Description	2
Intended Use	2
Applicability	2
Precautions.....	2
Features and Functions	3
Wiring Instructions	6
Evaluate Power Requirements	6
Connecting Main Power Wiring	6
Connecting Breakout Status Signal Wiring (Magic-Swing Operators)	6
Connecting Breakout Status Signal Wiring (Magic-Force Operators)	8
Wiring the Operator Switch Module (Magic-Force Operators).....	9
Wiring the Operator for Required Handing (Magic-Force Operators).....	10
Wiring the Power Close Speed Module	10
Wiring the "ON/OFF/HOLD OPEN" Switch and Power Switch.....	10
Wiring the Door Activation or Safety Device.....	10
Wiring Swing Guard T.....	11
Wiring Bodyguard-T.....	11
Wiring Superscan-T	11
Wiring Holding Beam.....	11
Wiring Other Sensors.....	11
Tune-In Instructions	12
Tuning in the iQ Using the Controller Pushbuttons	12
Index Tables	13
Status Codes.....	17
Door States.....	18
Final Tune-In Adjustments.....	19
Attachments	20
Attachment 1: Breakout Status Wiring for Magic Swing Operators	20
Attachment 2: Magic-Force Wiring Diagram	21
Attachment 3: Magic-Swing Wiring Diagram	22
Attachment 4: Monitored Sensor Wiring Diagram.....	23
Attachment 5: Non-Monitored Sensors Wiring Diagram	37
Attachment 6: iQ Terminal Block Connections.....	40
Attachment 7: iQ Controls and Indicators.....	41
Attachment 8: ANSI/BHMA and UL Compliance Requirements.....	43
Attachment 9: Hand Held Device Troubleshooting Aid.....	45
Attachment 10: Recommended Values for Door Configurations	46
Attachment 11: iQ Controller Fine Tuning.....	47

1 GENERAL DESCRIPTION

Intended Use

This manual provides abbreviated descriptive information, wiring instructions, and tune-in instructions for the iQ controller used with Magic-Swing™ and Magic-Force™. The manual is intended as a quick-reference guide. Attachment 7 illustrates the iQ controller controls and indicators.

Applicability

This manual is applicable on iQ control boxes used with Magic-Swing and Magic-Force operators.

Precautions

Magic-Touch Hold Open Time must be a minimum of 3 seconds to ensure compliance with ANSI/BHMA 156.19 "American National Standard for Power Assist and Low Energy Power Operated Doors," or most current ANSI/BHMA standards specifications.

All ANSI/BHMA and UL Requirements in Attachment 8 must be met before the door is put into operation.

Features and Functions

 = NOT SELECTABLE BY KEY PAD/PUSH BUTTONS

2S Operation

ON = push switch to open, push switch to close;

OFF = 2S mode disabled.

 **Close Position Tolerance:** Distance from full close that the door transitions from close check to full closed. This parameter is used when the door can't get closed and to eliminate recycles caused by obstructions. This sets the position where the controller interprets the door as fully closed.

 **Close Obstruction Time:** The amount of time in increments of 0.1 seconds the spring applies force when almost stopped or stopped when the controller indicates a state of **09**. Before increasing this parameter, check for mechanical issues.

Fire Alarm Mode:

0 = OFF: Keeps the Fire Alarm Mode OFF.

1 = OPEN: If not already Fully Open, the controller will ignore sensors and open the door slowly. If the door was previously obstructed, it will remain at the partially opened position. The controller will cause the door to remain open/partially opened for the duration of the Fire Alarm activation.

2 = CLOSE: Ignore Sensors and Hold Open Switch Mode: If the door is Fully Closed, the controller will ignore activation sensors. If not already Fully Closed, the controller will ignore sensors, Hold Open, and close the door. If the door is obstructed, it will not recycle and leave the motor drive in "freewheel".

3 = OPEN WITH RETRY: If not already Fully Open, the controller will ignore sensors and open the door slowly. If the door becomes obstructed, it will pause for 0.5 second and reattempt opening. The controller will cause the door to remain open/attempt opening for the duration of the Fire Alarm Activation.

4 = CLOSE: Ignore Hold Open Function Switch Mode: If the door is Fully Closed, the controller will ignore activation sensors. If not already Fully Closed, the controller will ignore the Hold Open but observe sensors normally if in automatic or one way. If the door is obstructed, it will not recycle and leave the motor drive in "freewheel".

 **Hold Beam Type:** Selects the hold beam type to be used for monitored or non-monitored applications. Monitored Hold Beams: Photobeam Pro or Optex OS12CT. Refer to wiring diagrams per application.

Hold Open Delay: Amount of time the door stays open after all sensors have cleared.

 **I/O Configuration:** Allows Motor 2 Power Close Relay feedback to be used instead of functions normally used with the selected input:

0 = Default

1 = TB5-7: Motor 1 Relay Feedback, TB3-9 Motor 2 Relay Feedback. **OPEN:** If not already Fully Open, the controller will ignore sensors and open the door slowly. If the door was previously obstructed, it will remain at the partially opened position. The controller will cause the door to remain open/partially opened for the duration of the Fire Alarm activation.

2 = TB2-5: Motor 1 Relay Feedback, TB3-9 = Motor 2 Relay Feedback. If the door is Fully Closed, the controller will ignore activation sensors. If not already Fully Closed, the controller will ignore sensors, Hold Open, and close the door. If the door is obstructed, it will not recycle and leave the motor drive in "freewheel".

Lock Delay: This allows the lock to mechanically unlock before door motion. Lock Delay only occurs when the door is full closed (when the control displays **00**). When the door is activated while the door is open, no Lock Delay occurs. Lock Delay will always occur if a door position switch is active. Value is in 0.1 second increments.

Lock Logic: Select to choose desired lock logic:

0 = Fail Safe: Unlocked when power is removed.

1 = Fail Secure: Locked when power is removed.

 **Lock Release Time:** The amount of time (in seconds) that the door will press closed before going open when the lock needs to release at the closed position. The value of zero disables the lock release.

 **Lock Release Torque:** The torque used in the lock release state. This parameter sets the maximum current available to the motor which is directly proportional to the door force.

 **Magic Touch Engagement:** Determines how smooth the door is to push after a Magic Touch activation.

Magic Touch Hold Open Time: Delay that the door stays open after all sensors have cleared after a Magic Touch operation. Parameter is in seconds, with increments of 0.1 seconds.

Magic Touch Sensitivity: Sets the threshold for manual activation. Setting of 1 is most sensitive. This setting is raised if false activations are seen.

Manual Mode Sensor Override: When set to **ON** the door sensors on the approach side will only be activated when a push plate, Magic Touch, or other Knowing Act activation signal is used.

Features and Functions (continued)

 = NOT SELECTABLE BY KEY PAD/PUSH BUTTONS

-  **Motor Starting Speed:** Affects the smoothness of the transition to powered door motion after manual door use.
- No Reverse on Obstruction:** Door will not recycle on close obstruction. Used in Low Energy only.
- Off Mode:** If set to close, all sensors are ignored when function switch is off.
- Open Acceleration:** Affects how responsive the door is to speed changes in the opening direction. This parameter is used when the door is lagging open speed. Startup torque and startup length should be investigated prior to increasing. This parameter affects all open motion speeds: open speed, open check speed, open learn speed, as well as open braking.
- Open Braking:** Adjusts how quickly the door slows down prior to check speed. Increasing this parameter increases braking power.
- Open Check Length:** The percent of door travel in which the door starts to slow down to open check speed. This parameter typically is adjusted based on door weight and open speed setting.
-  **Open Check Obstruction Time:** The amount of time in increments of 0.1 seconds that the door applies force when almost stopped or stopped when the controller indicates a state of **04**. Before increasing this parameter, check for mechanical issues, as well as speed and torque parameter settings.
-  **Open Check Recycle Speed:** The percent of Open Speed that is used when recycling in the Open Check Length.
- Open Check Speed:** The speed used during normal operation in the open check state **04** prior to arriving at full open. This speed is set to determine how fast the door arrives at full open after open speed. This parameter sets the target speed setting. Other parameters like open check torque, open acceleration, and open braking, as well as door properties like friction, door length, and door weight affect door speed.
- Open Check Torque:** The torque used during normal operation in open check state. This torque must be set to comply with ANSI/BHMA door force requirements. This parameter sets the maximum current available to the motor which is directly proportional to the door force. This torque setting is used in conjunction with Open Check Speed.
-  **Open Learn Speed:** The speed used on power up, during FIS, after an obstruction, and return from breakout. The controller display may indicate either 02 or 04 as a door state and still use Open Learn Speed based on the conditions listed prior. This speed is typically set higher than check speed, to allow faster door motion when not in the check zones, but still slower door motion than normal operation. This parameter sets the target speed setting. Other parameters like open learn torque, and open acceleration as well as door properties like friction, door length, and door weight affect door speed.
-  **Open Learn Torque:** The torque used on power up, during FIS, after an obstruction, and return from breakout. This torque must be set to comply with ANSI/BHMA door force requirements. This parameter sets the maximum current available to the motor which is directly proportional to the door force. This torque setting is used in conjunction with open learn speed.
- Open Obstruction Time:** The amount of time in increments of 0.1 seconds the door applies force when almost stopped or stopped when the controller indicates a state of "02". Before increasing this parameter, check for mechanical issues, as well as speed and torque parameter settings.
- Open Speed:** The speed used during normal operation in the opening state **02**. This parameter sets the target speed setting. Other parameters like open torque, open startup torque, open startup length, and open acceleration, as well as door properties like friction, door length, and door weight affect door speed.
-  **Open Startup Length:** The percent of door length in which the Open Startup Torque parameter is used. These parameters are used to overcome friction encountered at the beginning of open door motion. This parameter should be set as low as possible to ensure reliable operation.
-  **Open Startup Torque:** Open Startup Torque used when entering the opening state **02** and recycles. It is used for a configurable door length (determined by the Open Startup Length parameter). After this door length, the torque setting will revert to the Open Torque. This torque should be set greater than Open Torque to ensure that the controller can start door motion, overcome static friction, and avoid obstructions. This torque must be set to comply with ANSI/BHMA door force requirements. This parameter sets the maximum current available to the motor which is directly proportional to the door force.
-  **Open Stop:** The distance from full open that the door will stop in 0.1 degree increments. This parameter is used to minimize excessive oscillations that are seen at full open.
- Open Torque:** The torque used during normal operation following the end of Open Startup Length. This torque must be set to comply with ANSI/BHMA door force requirements. This parameter sets the maximum current available to the motor which is directly proportional to the door force. This torque setting is used in conjunction with Open Speed.
- Operate Delay:** Delays the motion of the door after the operate signal is received. Value is in 0.1 second increments.
-  **Overspeed Braking Angle:** Determines the position the door transitions to Open Check during manual operation following a Knowing Act. Setting the value to 99 disables the transition to Open Check.
-  **Overspeed Resistance:** Sets the sensitivity to external factors that allow the door to be used manually. Increasing this parameter will desensitize door motion to factors such as wind, stack pressure, and manual use.

Features and Functions (continued)

 = NOT SELECTABLE BY KEY PAD/PUSH BUTTONS

-  **Power Assist at Closed Mode:** Reduces the initial force required to initiate door motion when Magic Touch or Power Assist is enabled.
00 = OFF
01 = ON at Closed Door Position: When DPS contact is closed, Power Assist at Closed is enabled.
02 = Sensor Controlled: DMA1, DMA2, DMS1, DMS2, OHP and Power Close Cancel / Power Assist inputs will enable Power Assist at Closed when sensor is active.
-  **Power Assist Enable:** This feature allows the operator to assist the user so that the door is easier to open during manual operation.
-  **Power Assist Open Braking:** Sets the amount of resistance the operator provides as the door approaches full open when Power Assist is enabled. Decreasing this parameter will provide greater resistance provided by the Power Assist function.
-  **Power Assist Torque:** Sets the amount of helping force during manual operation.
-  **Power Close Angle:** The angle at which the motor starts to assist the spring while closing. If set to **90**, the motor will always be assisting from full open.
-  **Power Close at Closed Enable:** Power Close at Closed Enable is used to maintain the door pressing at full closed (state **22**).
-  **Power Close at Closed Torque:** Power Close Torque is the torque used during Power Close at Closed operation. This torque must be set to comply with ANSI/BHMA door force requirements. This parameter sets the maximum current available to the motor which is directly proportional to the door force.
-  **Power Close Check Angle:** The angle at which the door starts to slow down to Power Close Check Speed. This parameter typically is adjusted based on door weight and Power Close Speed setting. This value should be lower than the Power Close Angle.
-  **Power Close Check Speed:** This is the speed used during normal operation in the Power Close check state prior to arriving at full closed. This parameter sets the target speed setting. Other parameters like Power Close Speed, Power Close Check Angle, and Power Close Check Torque, as well as door properties like friction, door length, and door weight affect door speed.
-  **Power Close Check Torque:** The torque used during normal operation in Power Close check state. This torque must be set to comply with ANSI/BHMA door force requirements. This parameter sets the maximum current available to the motor which is directly proportional to the door force. This torque setting is used in conjunction with Power Close Check Speed.
-  **Power Close Enable:** Power Close allows the motor to assist the spring close to help overcome wind and stack pressure. This feature requires a Power Close Speed Module (part #517864) connected to the controller. Ensure forces are in compliance with applicable ANSI/BHMA Standard. To achieve this, door mounted sensors may be required to disable Power Close when a person is nearby.
-  **Power Close Obstruction Time:** The amount of time in increments of 0.1 seconds that the door applies force when almost stopped or stopped (when the controller indicates a state of **18**). Before increasing this parameter, check for mechanical issues, as well as Power Close Speed, Power Close Torque, Power Close Check Speed, and Power Close Obstruction Speed parameter settings.
-  **Power Close Speed:** The speed used during normal operation in Power Close (state **18**). This speed is set to change how long it takes the door to reach the Power Close Check Angle. This parameter sets the target speed setting. Parameters such as Power Close Torque and door properties like friction, door length, and door weight affect door speed.
-  **Power Close Torque:** The torque used during Power Close operation. This torque must be set to comply with ANSI/BHMA door force requirements. This parameter sets the maximum current available to the motor which is directly proportional to the door force. This torque setting is used in conjunction with Power Close Speed.
- Safety Logic:** Selects sensor type to be used for monitored or non-monitored applications. Monitored Sensors may require use of alternate wiring.
-  **Stall Sensor Ignore Position:** Ignores the stall sensor input from a percentage of the total door open. The full open position is 100 percent.
- Stall Torque:** Stall Torque is the torque used after obstruction and during stall events in the state of "15" or "16". This parameter affects the amount of force the door takes to push open while in stall.
- Unlock Time:** The time that the lock/strike is unlocked. This time starts when the door begins to open. The total time that the lock/strike is unlocked is the Lock Delay plus the Unlock Time. Unlock Time is 0 to 9.8 seconds. Each increment is 0.1 seconds. When set to 99 the lock/strike will stay unlocked until the door returns to the closed position (99 is the only value that is based on door position and not time).

2 WIRING INSTRUCTIONS

Evaluate Power Requirements

EVALUATE door system power requirements as follows:

- ENSURE power source is a dedicated 115 VAC, 50/60 Hz source with 20A circuit rating per two controllers.
- ENSURE power source is not shared with other equipment, i.e., cash registers, EAS systems, or other electromagnetic interference generators.

Connecting Main Power Wiring

⚠ Warning: To prevent injury to personnel, incoming electrical power to header must be de-energized before connecting control box electrical harness to electrical service.

- DE-ENERGIZE incoming electrical power to header.
- Refer to Attachments 2, 3, and 4, and using the wire nut provided, CONNECT ground wire assembly (P/N 711527) to electrical service ground wire.
- In a concealed location inside the header (not visible from the exterior of the header), DRILL a hole for a No. 8 screw.
- INSTALL ground wire ring terminal and star washer onto the No. 8 screw provided, and FASTEN screw, star washer, and ground wire to header.
- In a concealed location inside the header, DRILL a second hole for a No. 8 screw.
- INSTALL power line harness 412544 ring terminal and star washer onto the No. 8 screw provided, and FASTEN screw, star washer, and ground wire to header.
- Using the wire nuts provided, CONNECT power line harness 412544 to electrical service as follows:
 - CONNECT power pigtail assembly black wire to black (line) service wire.
 - CONNECT power pigtail assembly white wire to white (neutral) service wire.

Connecting Breakout Status Signal Wiring (Magic-Swing Operators)

⚠ Warning: To prevent injury to personnel and damage to equipment, control box power must be de-energized before connecting breakout status signal wiring.

⚠ Caution: If the motor is running and the breakout status switch is **not** connected, arcing across the breakout switch contacts can occur. This will result in damage to the breakout switch. To prevent damage from switch contact arcing, the breakout status switch must **always** be connected.

NOTES:

The breakout status switch must be used in all applications where there is no positive door stop in the breakout direction.

The auxiliary switch is the breakout status signal switch. The auxiliary switch was formerly the open check switch on the operator switch plate (top cam).

- Refer to Attachment 1, and CONNECT breakout status wiring.
- REMOVE quick-connect terminal (brown wire) from the normally open terminal of the auxiliary switch (formerly open check switch), and INSTALL onto normally closed terminal.

Continued Next Page

Continued From Previous Page

- SET the auxiliary cam for approximately 3° activation (toward breakout direction), and ADJUST cam as necessary to trip the corresponding micro switch prior to activation of the breakout switch.
- CONNECT yellow jumper wires installed on the single/dual motor harness as follows:
 - a. INSTALL stripped end of first jumper wire (from position 3 of the 8-pin connector on operator harness) into terminal 9 of control box connector TB3.
 - b. INSTALL stripped end of second jumper wire (from position 5 of the 8-pin connector on operator harness) into terminal 10 of control box connector TB3.

NOTE: In a swing-pair application, the breakout switches of each operator need to be wired in series to ensure that the control box will not open the doors if either breakout status switch is activated.
- IF application is a pair of swing doors, PERFORM the following:
 - a. REPEAT the previous two steps for the second door operator.
 - b. CONNECT stripped end of one yellow jumper wire from each operator to terminals 9 and 10 of control box connector TB3.
- Using a wire nut, CONNECT remaining wire from first operator to remaining wire on second operator.
- VERIFY breakout status/breakout cam is properly set as follows:
 - a. Refer to Figure 1, and visually INSPECT cams for proper setting.

Figure 1. Breakout Status/Breakout Cam Settings (Magic-Swing Operators)

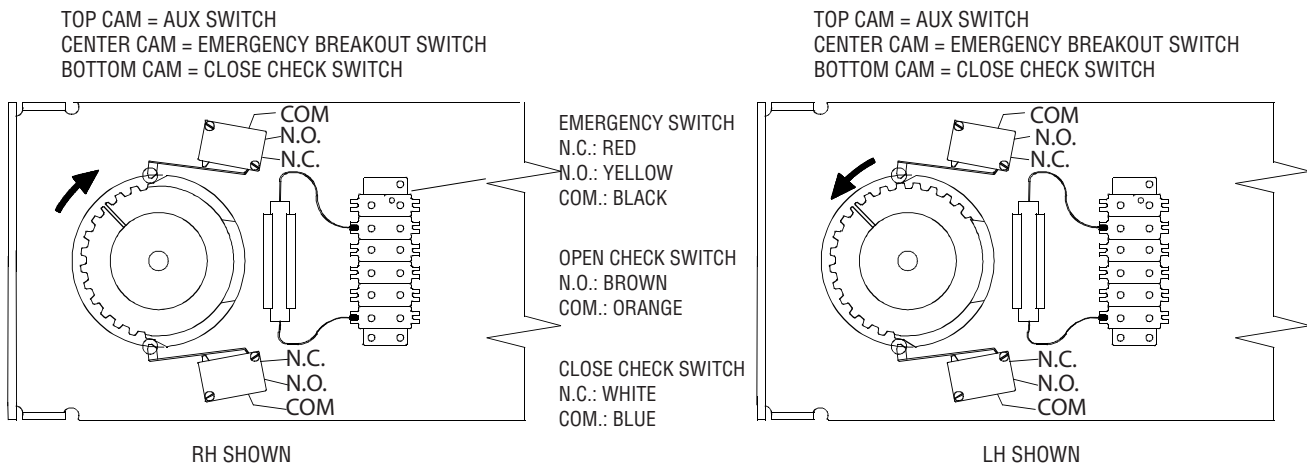

- b. UNPLUG TB3 from control box.

NOTE: When checking breakout status switch continuity, the switch is first checked with the door closed, then again with the door in the breakout (negative 3°) position. In a swing-pair application, both doors can be tested at the same time in the closed position. However, the doors must be tested **individually** when checking switch continuity with the doors in the breakout (negative 3°) position.

- c. ENSURE door is in the closed position.
- d. Using a multimeter, CHECK continuity between TB3 terminals 9 and 10, and ENSURE there is continuity.
- e. PUSH door in the breakout direction, and HOLD door at approximately the negative 3° position.
- f. Using a multimeter, CHECK continuity between TB3 terminals 9 and 10, and ENSURE there is an open circuit.
- g. RELEASE door.
- h. PLUG TB3 into control box.

Connecting Breakout Status Signal Wiring (Magic-Force Operators)

Warning: To prevent injury to personnel and damage to equipment, control box power must be de-energized before connecting breakout status signal wiring.

Caution: If the motor is running and the breakout status switch is **not** connected, arcing across the breakout switch contacts can occur. This will result in damage to the breakout switch. To prevent damage from switch contact arcing, the breakout status switch must **always** be connected.

NOTE: The breakout status switch must be used in all applications where there is no positive door stop in the breakout direction.

- SET "POWER" switch to **OFF**.
- IF single-operator application, PERFORM the following:
 - a. INSTALL one breakout status switch wire to terminal 9 of control box connector TB3.
 - b. INSTALL second breakout status switch wire to terminal 10 of control box connector TB3.
- IF dual-operator application, PERFORM the following to put the breakout switches in series:
 - a. INSTALL one breakout status switch wire from one operator to terminal 9 of control box connector TB3.
 - b. INSTALL one breakout status switch wire from second operator to terminal 10 of control box connector TB3.
 - c. CONNECT remaining two yellow breakout status switch wires together with a wire nut.
- VERIFY breakout status/breakout cams are properly set as follows:
 - a. Refer to Figure 2, and visually INSPECT cams for proper setting.
 - b. UNPLUG TB3 from control box.

NOTE: When checking breakout status switch continuity, the switch is checked twice; first with the door closed, then with the door in the breakout (negative 3°) position. In a swing-pair application, both doors can be tested at the same time in the closed position. However, the doors must be tested **individually** when checking switch continuity with the doors in the breakout (negative 3°) position.

**Figure 2. Breakout Status/Breakout Cam Settings
Magic Force Operators (Continued next page).**

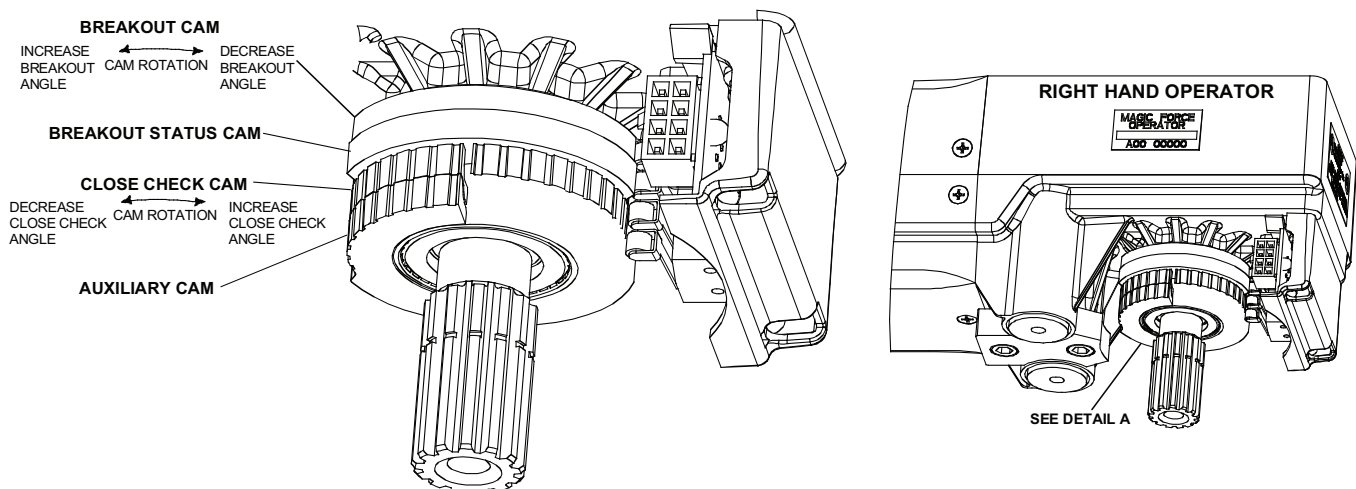

INITIAL CAM SETTINGS (LOOKING DOWN AT OPERATOR SPINDLE)

- ROTATE BREAKOUT CAMS COUNTER-CLOCKWISE UNTIL RAISED PORTION OF BREAKOUT STATUS CAM JUST CONTACTS SWITCH ROLLER.
- ROTATE CLOSE CHECK CAM CLOCKWISE UNTIL RAISED PORTION OF CAM ACTUATES SWITCH, THEN ROTATE CAM 10 DEGREES COUNTER-CLOCKWISE.
- ROTATE AUXILIARY CAM AS DESIRED.

Copyright 2019, Stanley Access Technologies, LLC. All rights reserved. Reproduction in whole or in part without the express written permission of Stanley is prohibited.

10.22.2019

Figure 2. Continued.
Breakout Status/Breakout Cam Settings - Magic Force Operators

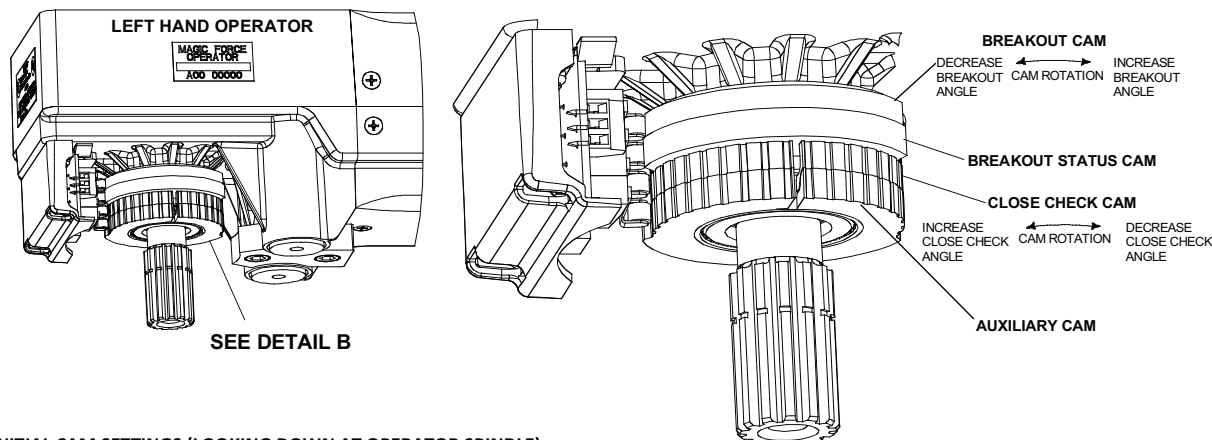

INITIAL CAM SETTINGS (LOOKING DOWN AT OPERATOR SPINDLE)

ROTATE BREAKOUT CAMS CLOCKWISE UNTIL RAISED PORTION OF BREAKOUT STATUS CAM JUST CONTACTS SWITCH ROLLER.

ROTATE CLOSE CHECK CAM COUNTERCLOCKWISE UNTIL RAISED PORTION OF CAM ACTUATES SWITCH, THEN ROTATE CAM 10 DEGREES CLOCKWISE.

ROTATE AUXILIARY CAM AS NEEDED

- c. ENSURE door is in the closed position.
- d. Using a multimeter, CHECK continuity between TB3 terminals 9 and 10, and ENSURE there is continuity.
- e. PUSH door in the breakout direction, and HOLD door at approximately the negative 3-degree position.
- f. Using a multimeter, CHECK continuity between TB3 terminals 9 and 10, and ENSURE there is an open circuit.
- g. RELEASE door.
- h. PLUG TB3 into control box.

Wiring the Operator Switch Module (Magic-Force Operators)

- Refer to Attachment 2 and CONNECT switch module harness 413791 to dual-adjustment closing speed control connector J4.
- IF auxiliary position switch will be used, refer to Figure 3, and PERFORM the following:
 - a. LIFT switch module release lever up, and SLIDE switch module out of operator housing.

Figure 3. Wiring the Auxiliary Position Switch (Magic-Force Operators)

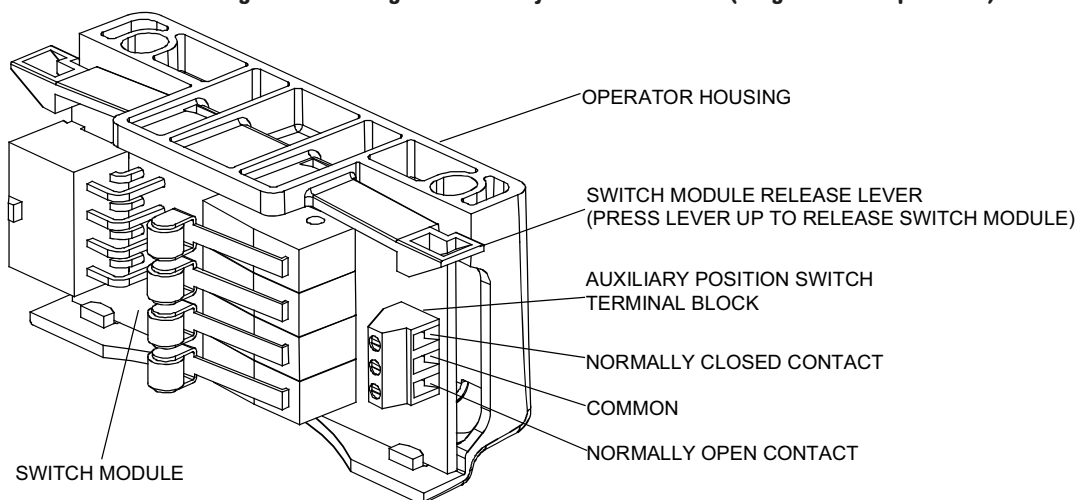

- b. CONNECT wiring to auxiliary position switch terminal block as shown.
- c. SLIDE switch module into operator housing until switch module release lever snaps into place.

Wiring the Operator for Required Handing (Magic-Force Operators)

NOTE: Operator cams are factory-set for right hand operation.

- Refer to Figure 4, and DETERMINE door handing.

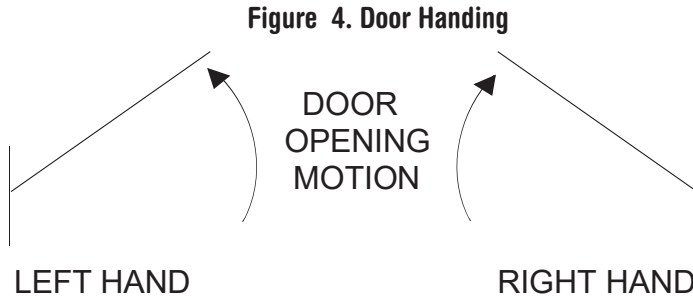

- CONNECT operator harness from close speed module to control box motor 1 and motor 2 connectors, if applicable

Wiring the Power Close Speed Module

Refer to Attachment 2 and CONNECT the Power Close Speed Module.

Wiring the “ON/OFF/HOLD OPEN” Switch and Power Switch

- Refer to Attachment 2, and CONNECT **ON/OFF/HOLD OPEN** switch wiring as follows:

TB2 Terminal	Connection	Switch Wire Color
1	Hold Open	Yellow
2	Common	Orange
3	Automatic On	Violet

- SET **POWER** switch to **OFF**.
- CONNECT **POWER** switch harness 516857-1 to power harness 415000.
- CONNECT line connect harness 412544 to power harness 415000.

Wiring the Door Activation or Safety Device

NOTE: Attachments 2, 3, and 4 illustrate typical wiring for various devices. Though the specific device may not be shown, this attachment can be used as a general guide. Specific wiring instructions from the manufacturer must also be consulted.

Refer to Attachments 2, 3, 4 and applicable manufacturer’s instructions, and CONNECT door activation or safety device.

Wiring Swing Guard T

⚠ Caution: Do not connect Swing Guard T Daughter Board or Sensors until control box is fully tuned.

NOTE: Select Swing Guard T when in **Step 9 of Table 1** if tuning with pushbuttons, even though Swing Guard T has not been connected at this time. If tuning with 'Hand Held Device', select Swing Guard T for Safety Logic.

1. Set DIP switches on the Swing Guard T Controller so that the sensor is always enabled (DIP switch 3 DOWN for auto).
2. To perform a **first learn** on the Swing Guard T system, Manual Mode Sensor Override must be set to OFF or the door will not open and the **learn** will not complete. Once the **learn** is complete, set Manual Mode Sensor Override to ON.
3. Wire SU100 into TB4.

NOTE: Do not use purple wires on Swing Guard T Controller wire harness.

TB1 Terminal	Connection	Swing Guard T Wire Color
1	(+) Power for Swing Guard T	Red
2	Serial Communication	Green
3	Serial Communication	White
4	(-) Power for Swing Guard T	Black

NOTE: Refer to the Swing Guard T installation manual for Sensor Head mounting locations, DIP switch settings, angle adjustments and routing of wire harnesses.

Wiring Bodyguard-T

The Bodyguard-T does not require a lockout relay for use with the iQ control box. The iQ control box generates the data signals for door open, closing, and closed positions. Refer to Attachment 2, 3, or 4, as applicable for wiring connections. Program the Bodyguard-T Relay Output to #1.

Wiring Superscan-T

Refer to Attachment 2, 3, or 4 as applicable for wiring connections.

Wiring Holding Beam

The Holding Beam input is used in applications when there is a rail-mounted holding beam. When the door is closing and the beam is obstructed, the door will not open until the door is completely closed and the header-mounted sensor becomes active. When the door is open and the beam is obstructed, the door will remain open. Refer to Attachment 2, 3, or 4 as applicable for wiring connections.

Wiring Other Sensors

Refer to Attachment 2, 3, 4 or 5 as applicable for wiring connections.

4 TUNE-IN INSTRUCTIONS

Tuning in the iQ Using the Controller Pushbuttons

1. To change the INDEX:
 - Hold ENTER switch while pressing UP or DOWN to get to desired INDEX
2. To change a VALUE:
 - Unlock the keypad by setting index 99 to value 00.
 - After the desired INDEX is selected, release ENTER and within 2.5 seconds press UP or DOWN to get the desired VALUE. (If the UP or DOWN buttons are not pressed within 2.5 seconds of releasing the ENTER button, the display will change from the VALUE back to the STATUS.)
3. To display STATUS CODE:
 - A few seconds after the VALUE is selected, the display indicates the STATUS CODE
4. To show the INDEX and VALUE
 - To show the INDEX, hold ENTER. Once ENTER is released the display will show the VALUE of that INDEX.
5. Read the descriptions entirely before performing each step. Check the INDEX and VALUE after each step.
6. To store changes in permanent memory:
 - Cycling door open one time will store changes.
7. To lock keypad:
 - Lock keypad by setting index 99 to value 01 or by turning power OFF and then ON.
8. To access the door cycle counter function:
 - a. Ensure that the keypad is locked by setting index 99 to 01.
 - b. Ensure that the index is set to any index but 99.
 - c. Press the up or down key to access the door cycle counter.
 - d. The display will show “**dc**” followed by four pairs of digits, followed by “**dc**”. For example, if the door count was 12345678 cycles the door will display “**dc**” “**12**” “**34**” “**56**” “**78**” “**dc**.”

Index Tables

Table 1. FIS Procedure Using Pushbuttons

Step	Description	Display														
		Index	Value	Status Code												
1	Set Function switch to Closed .															
2	Turn power on.															
3	Unlock keypad.	99	0	00												
4	Restart FIS.	96	1	A0												
5	Select door type (Refer to Table 2).	0	Refer to Table 2	A0												
6	Select Motor 1 Handing.	1	00 = Right hand 01 = Left hand	A0												
7	Select Motor 2 Handing.	2	00 = Right hand 01 = Left hand	A0												
8	Accept FIS. Display will show A1 .	3	1	A1												
9	<p>Make changes: Safety Logic.</p> <p>(NOTE: If there are no sensors connected, leave value of 00).</p> <table border="1" style="margin: 10px auto;"> <thead> <tr> <th colspan="2">ABBREVIATIONS</th> </tr> </thead> <tbody> <tr> <td>DM</td> <td>Door Mounted Sensors</td> </tr> <tr> <td>OHP</td> <td>Overhead Presence Sensor</td> </tr> <tr> <td>ACT</td> <td>Activation Side Presence Sensor</td> </tr> <tr> <td>STL</td> <td>Stall Presence Sensor</td> </tr> <tr> <td>SAF</td> <td>Safety Presence Sensor</td> </tr> </tbody> </table>	ABBREVIATIONS		DM	Door Mounted Sensors	OHP	Overhead Presence Sensor	ACT	Activation Side Presence Sensor	STL	Stall Presence Sensor	SAF	Safety Presence Sensor	11	<p>Safety Logic. INDEX 11 - 00 to 15</p> <p>00 = Sensor</p> <p>01 = Sentrex</p> <p>02 = Carpet</p> <p>03 = Carpet 12 Sec.</p> <p>04 = Non-Monitored Bi-Fold</p> <p>05 = Monitored DM & OHP. ACT, STL & SAF, both single & pair</p> <p>06 = Monitored DM & OHP Dual Egress. STL, ACT, STL & SAF</p> <p>07 = Monitored OHP & Photobeam. SAF & Photobeam</p> <p>08 = Monitored DM ACT. ACT both single & pair</p> <p>09 = Monitored OHP Bi-Fold. SAF</p> <p>10 = Monitored DM. ACT & STL both single & pair</p> <p>11 = Two OHP Monitored Bi-fold. SAF, Bi-Fold/Swing</p> <p>12 = Monitored Hub Based Sensors. ACT & STL</p> <p>13 = Swing-Guard T</p> <p>14 = Monitored DM Stall & OHP both single and pair. STL & SAF</p> <p>15 = Monitored DM Stall & OHP Dual Egress. STL & SAF</p>	A1
ABBREVIATIONS																
DM	Door Mounted Sensors															
OHP	Overhead Presence Sensor															
ACT	Activation Side Presence Sensor															
STL	Stall Presence Sensor															
SAF	Safety Presence Sensor															
10	Lock Keypad.	99	01	00												
11	Final Tune in.	--	--	--												

Copyright 2019, Stanley Access Technologies, LLC. All rights reserved. Reproduction in whole or in part without the express written permission of Stanley is prohibited.

10.22.2019

Table 2. iQ Mode Values

Code	iQ Operational Mode
01	Dura-Glide door style—Single Motor
02	Dura-Glide door style—Dual Motor
03	Magic-Swing Door Style—Single Motor
04	Magic-Swing Door Style—Dual Motor
05	Magic-Force Door Style—Single Motor
06	Magic-Force Door Style—Dual Motor
07	Magic-Force Door Style—Single Motor Low Energy
08	Magic-Force Door Style—Dual Motor Low Energy
09	Fold door style--Single Motor
10	Fold door Style--Dual Motor

Table 3. Index List

Description	Index
iQ Mode Specific Door Operational Values - These depend upon the mode selected	00-89
Reserved	90-95
Command: Restart FIS. Entering 01 will cause FIS to restart.	96
Firmware: Entering 01 will display FE followed by two pairs of digits followed by FE . For example, if the firmware is 0609, the controller will display FE 06 09 FE .	97
Command: Restart auto configuration. Entering 01 sets the Control Box to A1 , which keeps all previous values and then the Control Box re-learns the encoder count.	98
Command: Lock. Entering 01 will lock all VALUE imports except this INDEX. This prevents inadvertent changes to input values. VALUES may be unlocked by entering 00 in this INDEX.	99

Table 4. Magic Force/Magic Swing Configuration Codes

Index	Min. Value	Max. Value	Description	Motor	Defaults	
					Low Energy	Full Energy
0	1	125	Open Speed**	M1	32	61
1	1	125	Open Check Speed**	M1	6	6
3	0	99	Open Check Length	M1	20	30
4	0	99	Magic Touch Sensitivity (01= max. Sensitivity)	M1	0	0
5	1	99	Magic Touch Hold Open Time (25 sec. max. = 99%)	M1	16	16
6	1	99	Hold Open Delay (25 sec. max. = 99%)	M1	22	6
7	0	99	Open Torque	M1	35	60
8	0	99	Open Check Torque	M1	35	60
9	0	99	Stall Torque	M1	8	8
11	0	15	Safety Logic	M1	0	0
12	0	1	2S Operation	M1	0	0
13	3	60	Open Obstruction Time (60 = 1.5 seconds)	M1	20	20
14	0	40	Open Acceleration	M1	20	10
15	0	10	Open Braking	M1	8	8
16	0	50	Operate Delay (0.1 sec. increments: 5.0 sec. max.)	M1	0	0
17	0	1	No Reverse on Obstruction	M1	0	0
18	0	50	Lock Delay	M1	0	0
19	0	1	Manual Mode Sensor Override	M1	0	0
20	1	125	Open Speed**	M2	32	61
21	1	125	Open Check Speed**	M2	6	6
23	0	99	Open Check Length	M2	20	30
24	0	99	Magic Touch Sensitivity (01= max. Sensitivity)	M2	0	0
25	1	99	Magic Touch Hold Open Time (25 sec. max. = 99%)	M2	16	16

****Max value listed in table not accessible from keypad.**

Table 4 Continued Next Page

Copyright 2019, Stanley Access Technologies, LLC. All rights reserved. Reproduction in whole or in part without the express written permission of Stanley is prohibited.

10.22.2019

Table 4. Magic Force/Magic Swing Configuration Codes (Continued)

Index	Min. Value	Max. Value	Description	Motor	Defaults	
					Low Energy	Full Energy
26	1	99	Hold Open Delay (25 sec. max. = 99%)	M2	22	22
27	0	99	Open Torque	M2	35	60
28	0	99	Open Check Torque	M2	35	60
29	0	99	Stall Torque	M2	8***	8***
31	0	1	Off Mode	M1	0	0
32	0	1	Lock Logic	M1	1	1
33	3	60	Open Obstruction Time (60 sec. = 1.5 seconds)	M2	20	20
34	0	40	Open Acceleration	M2	20	10
35	0	10	Open Braking	M2	8	8
36	0	50	Operate Delay (0.1 sec. increments: 5.0 sec. max.)	M2	0	0
37	1	99	Unlock Time (99 = unlocked until full closed)	M1	10	10
38	0	4	Fire Alarm Mode	M1	0	0

***Please refer to *Features and Functions* for more information on parameters.**

****Max value listed in table not accessible from keypad.**

*****Default value is different for Magic-Swing.**

Status Codes

Table 5. Status Codes

Status Code	Description	Remedy/Cause
0	Normal	
0b	Obstruction	
20	Breakout	
33	System Error	Door moves slowly on one cycle: <ul style="list-style-type: none"> • Note it. No action required. Door moves slowly on several cycles. Display shows 33 on slow cycles: <ul style="list-style-type: none"> • Reset Power. • If code does not clear, call Tech Support.
34	Internal Communication Error: Type 1 (see Attachment 7)	Door moves slowly on one cycle: <ul style="list-style-type: none"> • Note it. No action required. Door moves slowly on several cycles. Display shows 34 on slow cycles: <ul style="list-style-type: none"> • Reset Power. • If code does not clear, call Tech Support.
35	Motor Drive Failure	Replace Controller.
36	Internal Communication Error: Type 2 (see Attachment 7)	Door moves slowly on one cycle: <ul style="list-style-type: none"> • Note it. No action required. Door moves slowly on several cycles. Display shows 36 on slow cycles: <ul style="list-style-type: none"> • Reset Power. • If code does not clear, call Tech Support.
55	Stall State	
A0	Unconfigured	
A1	FIS in Progress	
A2	FIS Learn Complete	
b1	Encoder Error	Cable failure.
b2	Encoder Mismatch	Wrong Encoder/Magnet.
b3	Encoder Failure	Wrong Encoder/Magnet or cable failure. Ensure motor is attempting to move.
c1	Learn Error	
dB	Troubleshooting Mode	

Continued next page.

Table 5. Status Codes (continued)

Status Code	Description	Remedy/Cause
E2 / ho	Door Held Open	Use best practices to troubleshoot using hand held device and provided wiring diagrams.
E3	Door Length Error	1. Check mechanical issues, components. 2. Re-do First Installation Sequence (FIS).
E5	Motor Drive Error	
E6	Power Close Control Failure	Verify Power Close Speed Module wiring.
F0	Stall Sensor Failure	Verify sensor wiring and safety logic setting.
F1	Approach Sensor Failure	Verify sensor wiring and safety logic setting.
F2	Hold Beam Sensor Failure	Verify sensor wiring and safety logic setting.
F4	Safety 1 Sensor Failure	Verify sensor wiring and safety logic setting.
F5	Safety 2 Sensor Failure	Verify sensor wiring and safety logic setting.
FA	Fire Alarm Active	

Door States

Table 6. Door States

Door State	Description
00	Door State is Closed.
02	Door State is Opening.
04	Door State is in Open Check.
06	Door State is Full Open.
09	Door State is in Close Check.
15	Door State is Open Stop.
16	Door State is Close Stop.
18	Door State is in Power Close.
19	Door State is in Lock Release.
21	Door State is in Power Assist.
22	Door State is in Power Close at Closed.
NOTES:	
<ul style="list-style-type: none"> If the current status code is “Normal operation—All OK”, the iQ will show the current door state. Otherwise, the iQ alternates between showing the current status code and the door state. d1 and d2 displayed when controlling more than one door. Any state that follows d1 is referencing door #1. Any state that follows d2 is referencing door #2 	

Final Tune-In Adjustments

- Refer to ANSI/BHMA A156.10, “American National Standard for Power Operated Pedestrian Doors,” or ANSI/BHMA A156.19, “American National Standard for Power Assist and Low Energy Power Operated Doors,” or the most current ANSI/BHMA standards.
- CYCLE and RECYCLE door several times to verify proper speeds and forces, and PERFORM adjustments in the following order:
 - a. ADJUST **CK** (Close Check) cam.
 - b. ADJUST Open Speed.
 - c. ADJUST Open Check Speed.
 - d. ADJUST **CLS** (Close Speed) rheostat.
 - e. ADJUST **CK** (Close Check Speed) rheostat.

NOTE: Adjustments to the **CK** (Close Check) rheostat also affect closing speed. Closing speed must always be checked after adjusting Close Check Speed.
 - f. ADJUST **CLS** (Close Speed) rheostat.

⚠ Caution: To prevent motor overheating and premature motor failure, **Stall Torque** must not be set too high.
 - g. ADJUST **Stall Torque**.
 - h. ADJUST torque.
 - i. ADJUST time delay.

⚠ Warning: The **Magic-Touch™ Hold Open Time** must be a minimum of 3 seconds to ensure compliance with ANSI/BHMA A156.19 “American National Standard for Power Assist and Low Energy Power Operated Doors,” or most current ANSI/BHMA standards.
 - j. ADJUST **Magic-Touch™ Hold Open Time**.
 - k. ADJUST breakout and breakout status cams.
 - l. ADJUST Power Close Speeds, Torques and Angles.
 - m. ENSURE all ANSI/BHMA, and UL compliance requirements are met.
 - n. POWER DOWN the door, POWER UP the door, and ENSURE that all settings have been stored in the controller.
 - o. Verify that the correct Safety Logic has been selected for Sensor Monitoring and that JP301 is installed.
 - p. Please refer to Attachment 11 for iQ Controller Fine Tuning for adjustment recommendations.

5 ATTACHMENTS

Attachment 1 Breakout Status Wiring for Magic-Swing Operators (Sheet 1 of 1)

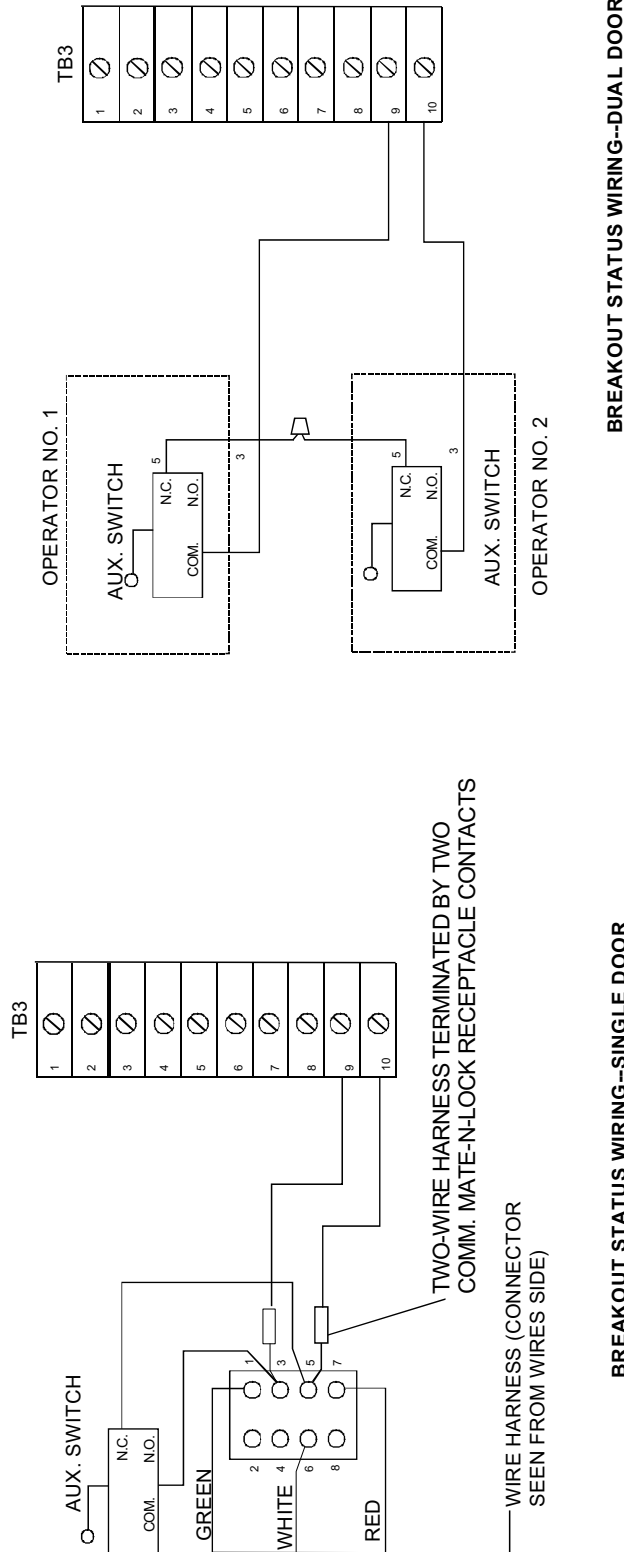

Attachment 2 Magic-Force Wiring Diagram—iQ (Sheet 1 of 1)

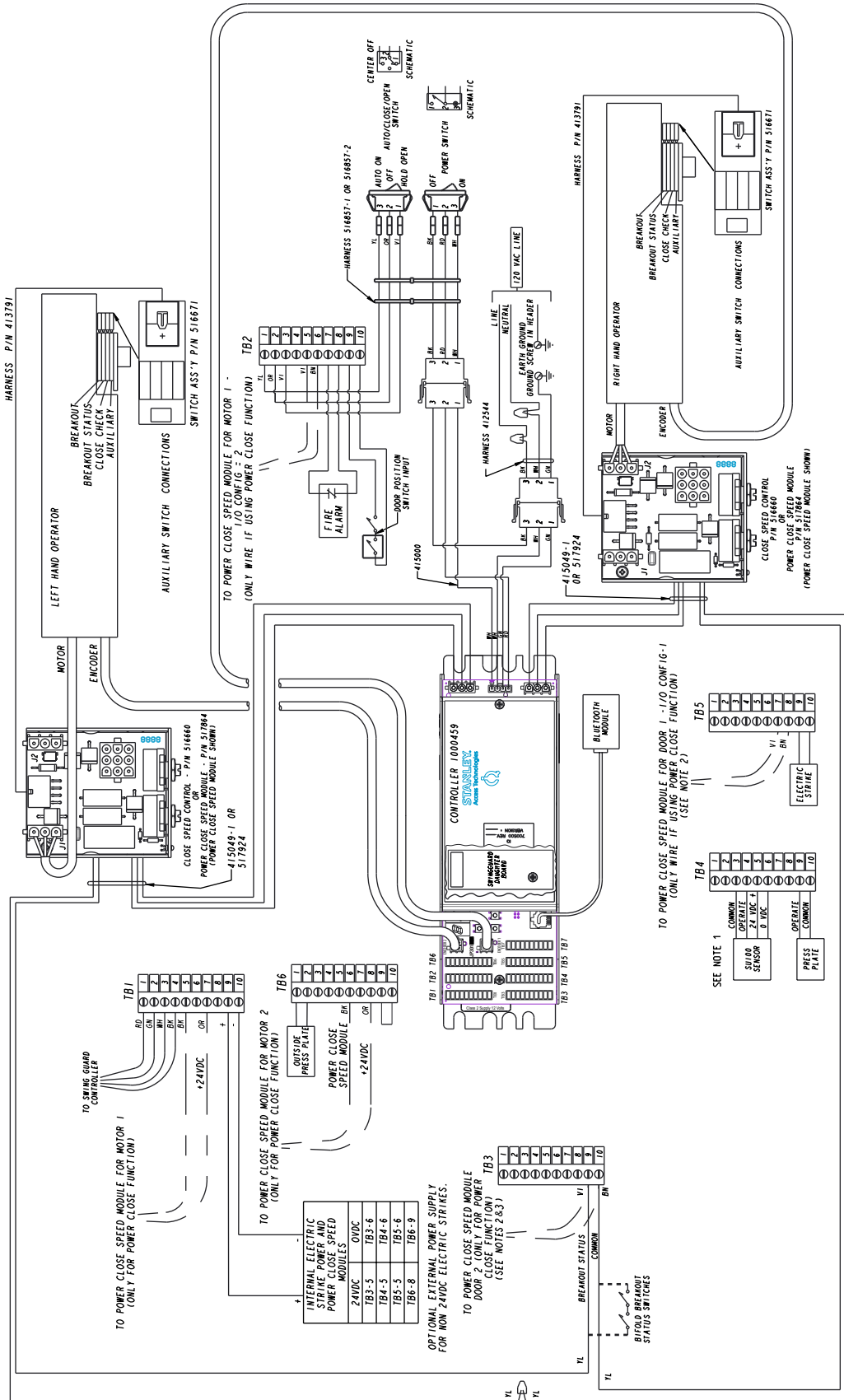

NOTES:
 1. MULTIPLE SU100 SENSOR WIRES ARE WIRED IN PARALLEL.
 2. WHEN POWER CLOSE IS REQUIRED, THE MONITORING INPUTS (BREAKOUT INPUT TB3 - 9 AND HOLDING BEAM INPUT TB5 - 7), MUST BE CONFIGURED WITH I/O CONFIGURATION PARAMETER.
 3. IF USING TB3 - 9 FOR POWER CLOSE MONITORING, BREAKOUT STATUS SWITCH MUST BE DISCONNECTED.

Attachment 3 Magic-Swing Wiring Diagram—iQ (Sheet 1 of 1)

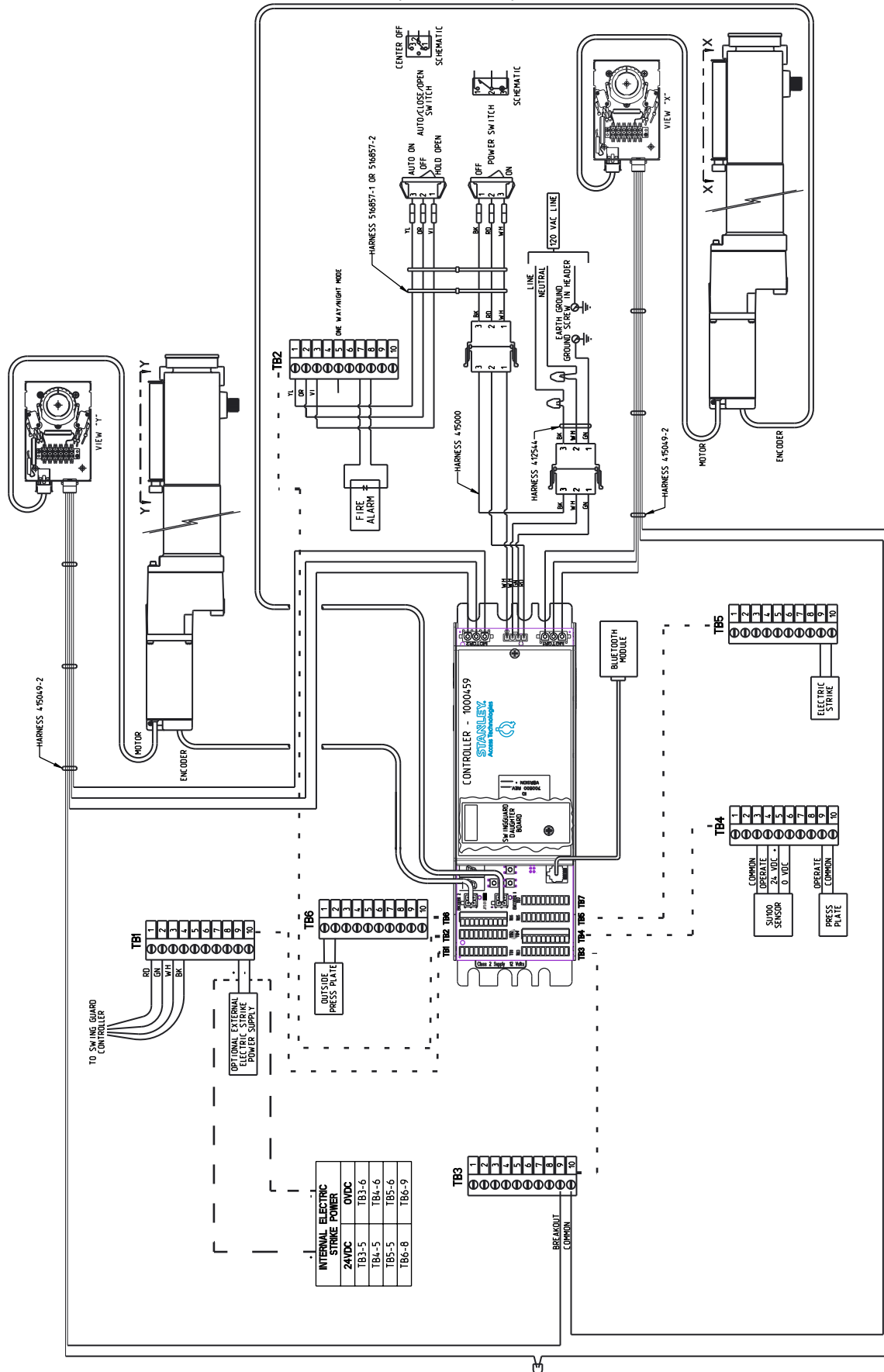

NOTE:
MULTIPLE SUIVO SENSOR WIRES ARE WIRED IN PARALLEL.

Attachment 4 Monitored Sensors Wiring Diagrams (Sheet 1 of 14)

DOOR MOUNTED STALL & ACT WITH OVERHEAD PRESENCE SWING DOOR SINGLE SAFETY LOGIC - 05

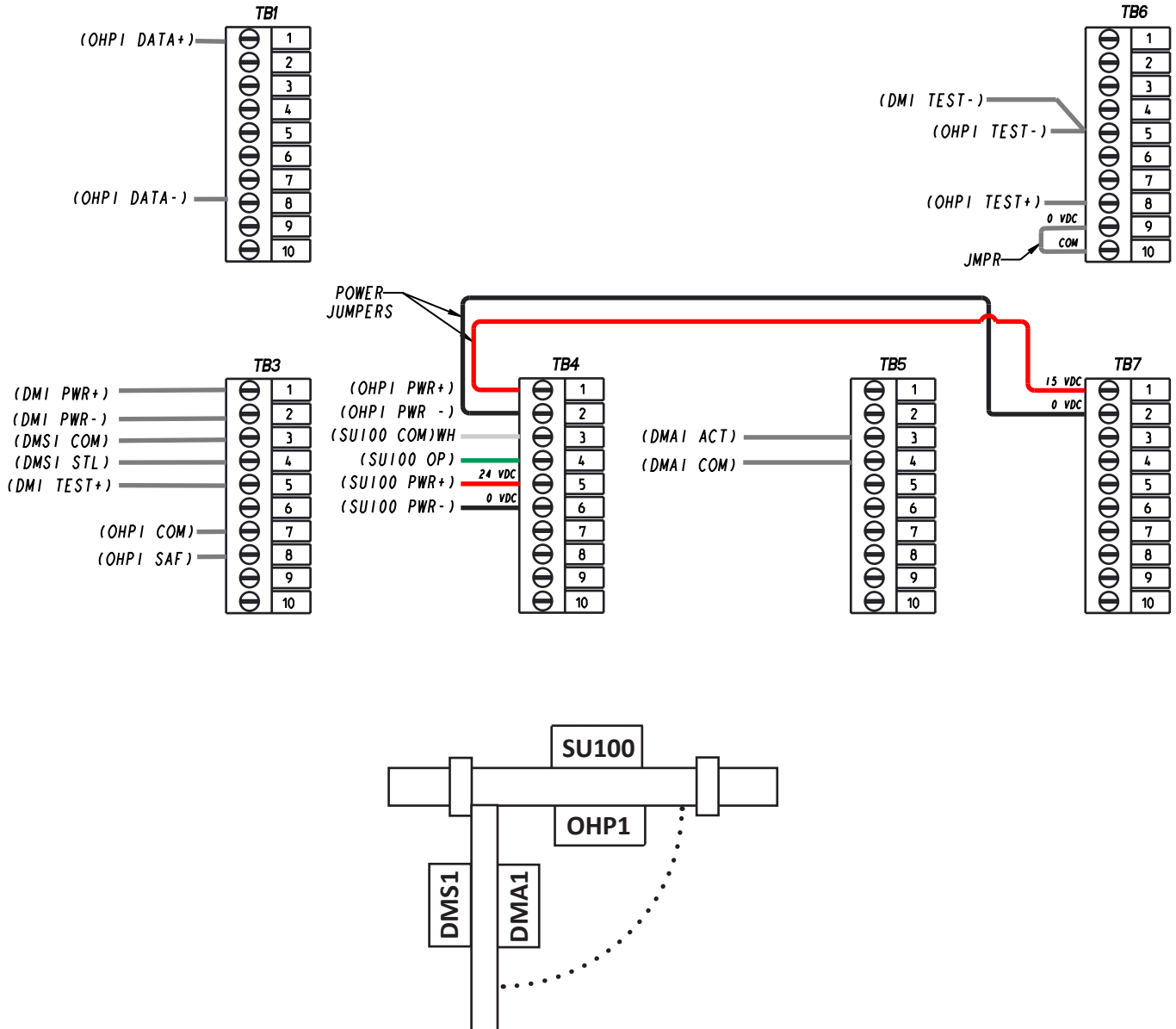

Copyright 2019, Stanley Access Technologies, LLC. All rights reserved. Reproduction in whole or in part without the express written permission of Stanley is prohibited.

10.22.2019

Attachment 4 Monitored Sensors Wiring Diagrams (Sheet 2 of 14)

DOOR MOUNTED STALL & ACT WITH OVERHEAD PRESENCE SWING DOOR PAIR SAFETY LOGIC - 05

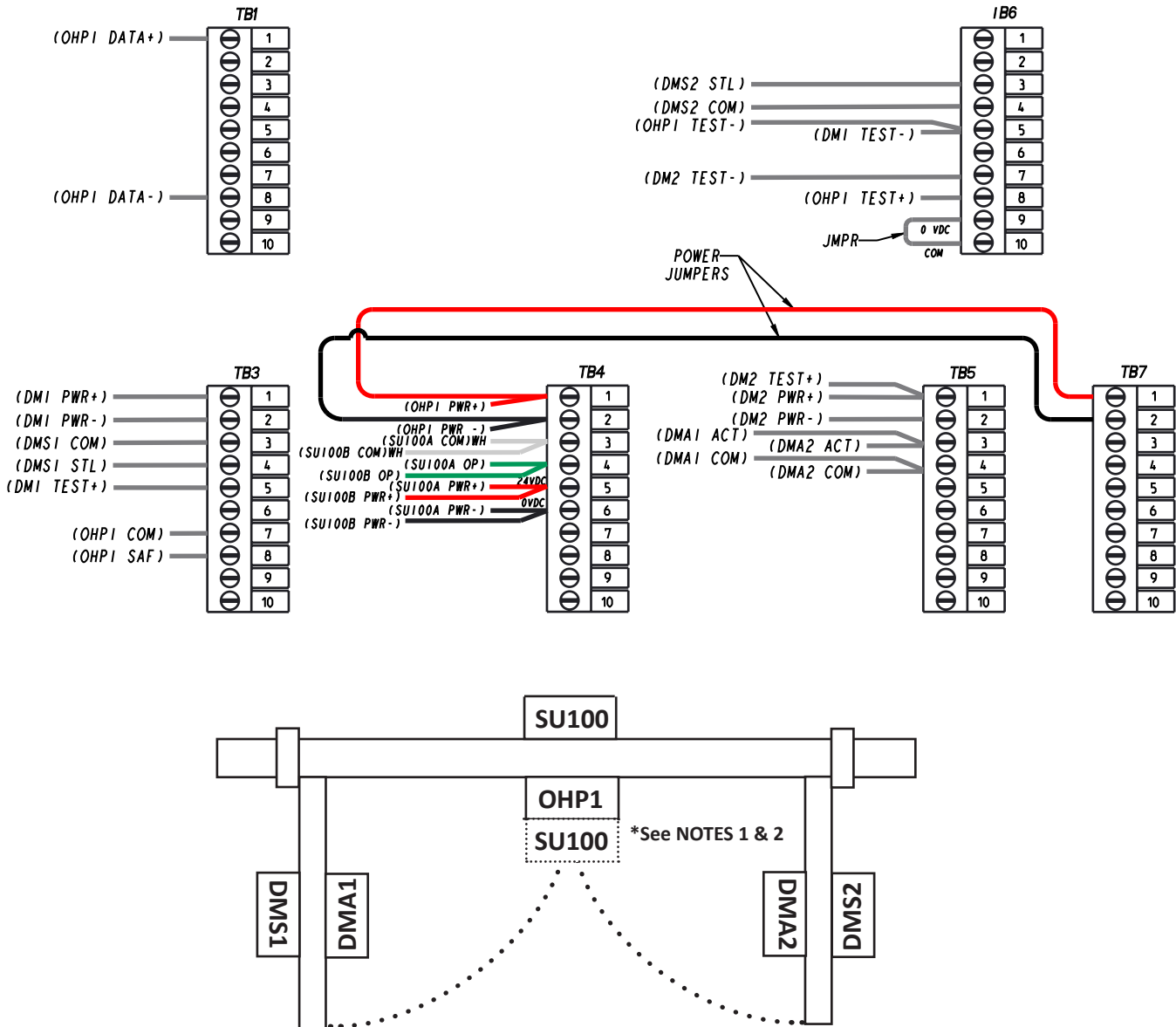

NOTES:

1. Optional SU100 for two-way traffic.
2. If the optional SU100 for two-way traffic is needed, this additional SU100 requires adding a 24VDC external power supply into TB4-1 and TB4-2 and removing the 15V power jumpers from TB7 and TB4 (see Attachment 5 sheet 3).

Attachment 4 Monitored Sensors Wiring Diagrams (Sheet 3 of 14)

DOOR MOUNTED STALL & ACT WITH OVERHEAD PRESENCE SWING DOOR DUAL EGRESS SAFETY LOGIC - 06

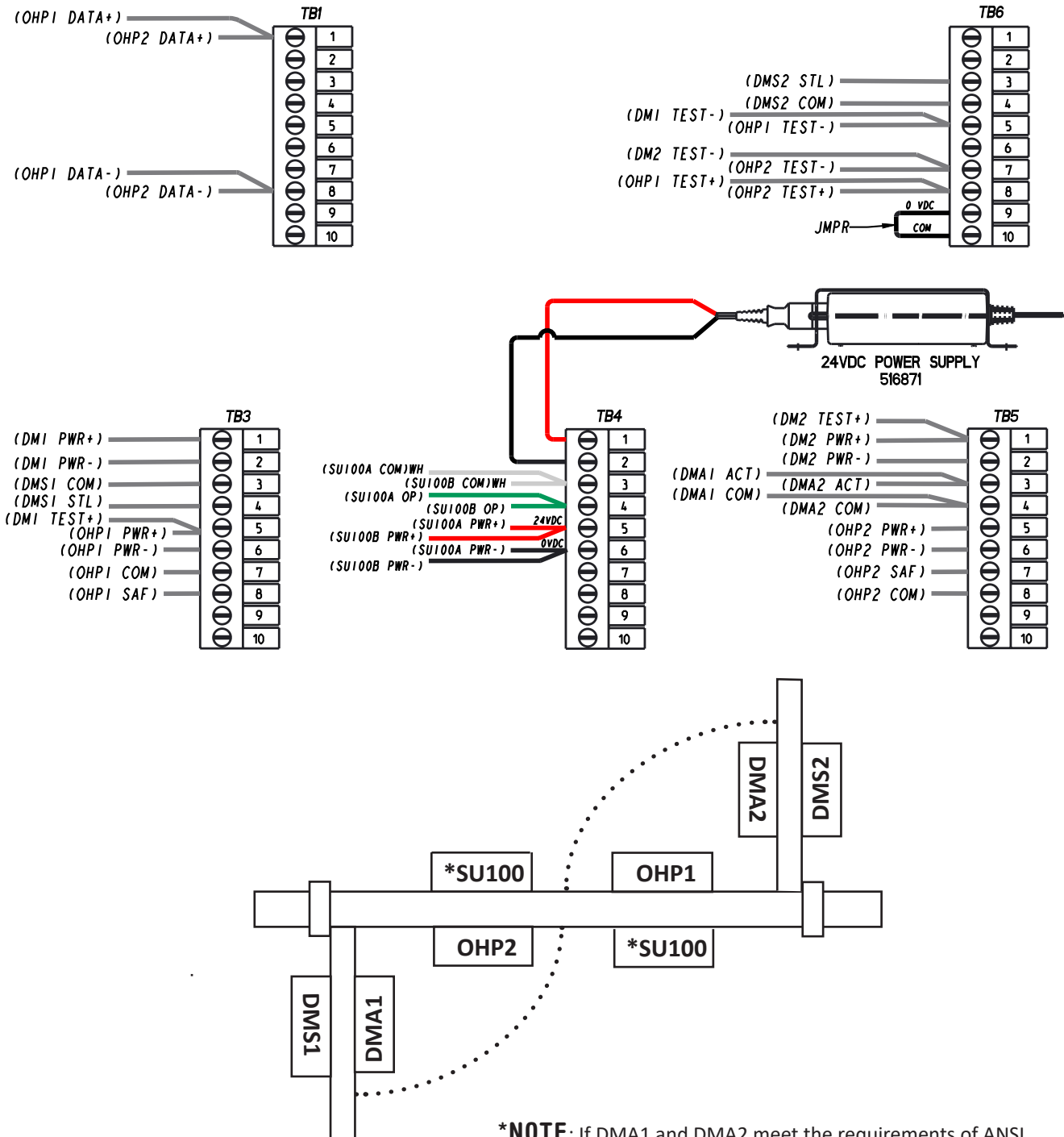

***NOTE:** If DMA1 and DMA2 meet the requirements of ANSI A156.10 section 8.2.2.3, the SU100 sensors are not required.

Attachment 4
Monitored Sensors Wiring Diagrams
 (Sheet 4 of 14)

OVERHEAD PRESENCE & PHOTOBEAM (PB)
SWING DOOR SINGLE & PAIR
SAFETY LOGIC - 07

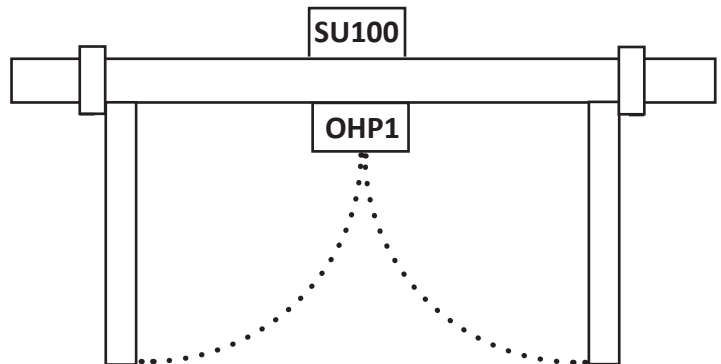
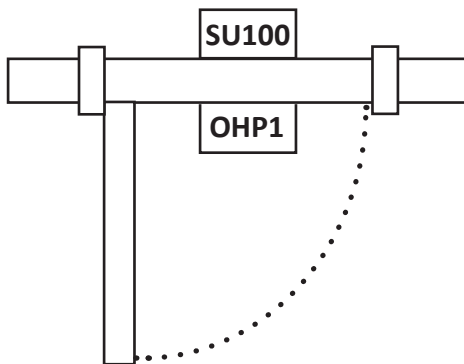
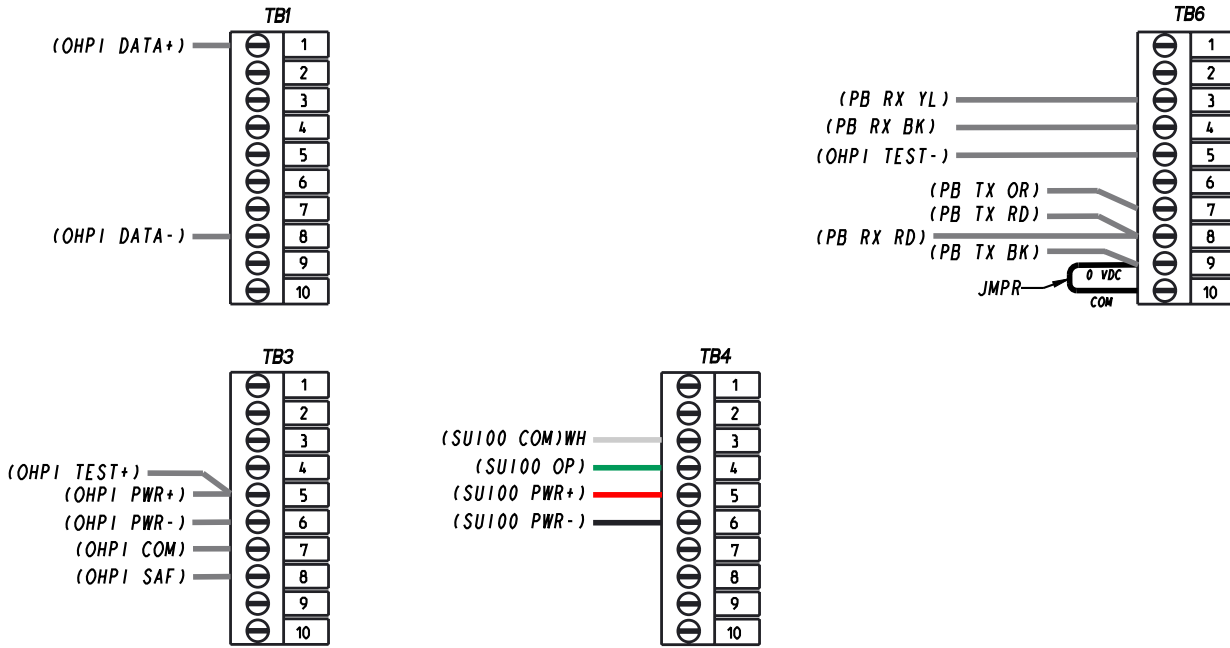

Copyright 2019, Stanley Access Technologies, LLC. All rights reserved. Reproduction in whole or in part without the express written permission of Stanley is prohibited.

10.22.2019

Attachment 4 Monitored Sensors Wiring Diagrams (Sheet 5 of 14)

**DOOR MOUNTED ACT
SWING DOOR SINGLE
SAFETY LOGIC - 08**

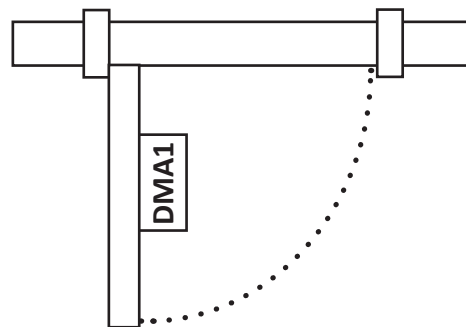
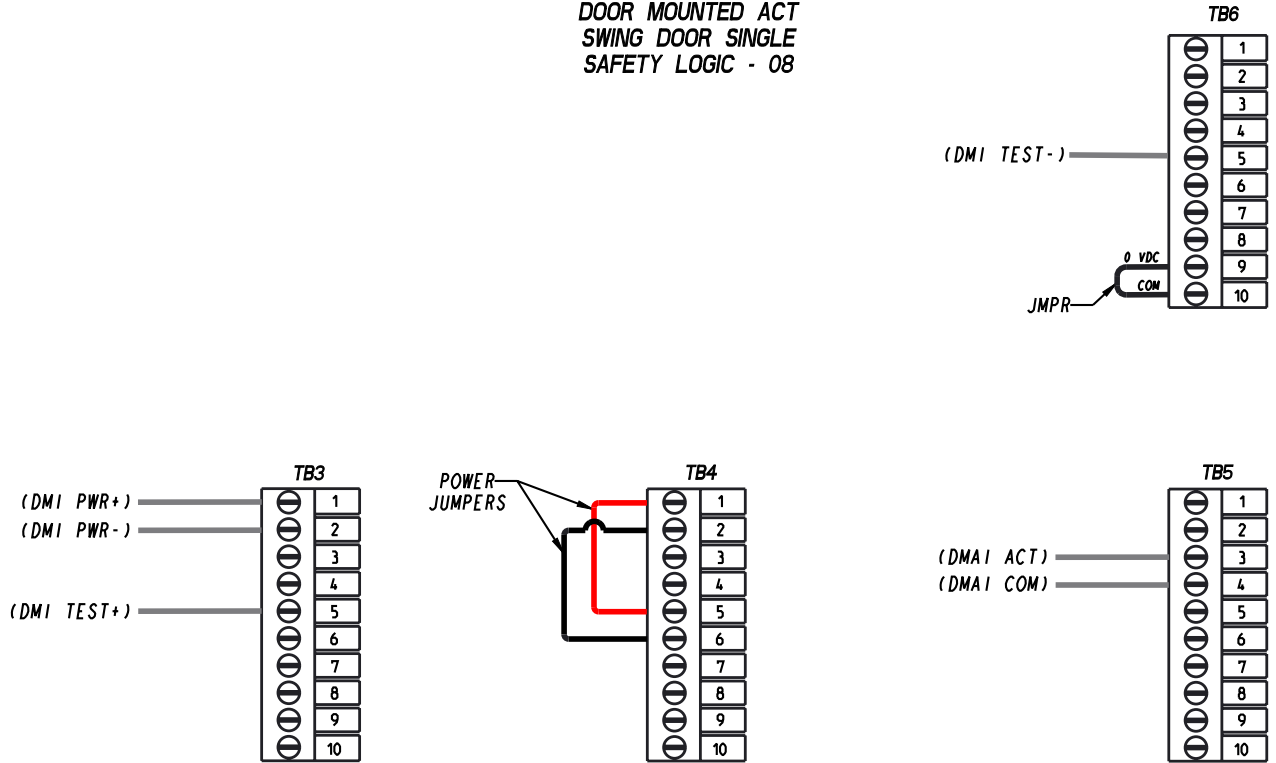

Attachment 4 Monitored Sensors Wiring Diagrams (Sheet 6 of 14)

**DOOR MOUNTED ACT
SWING DOOR PAIR
SAFETY LOGIC - 08**

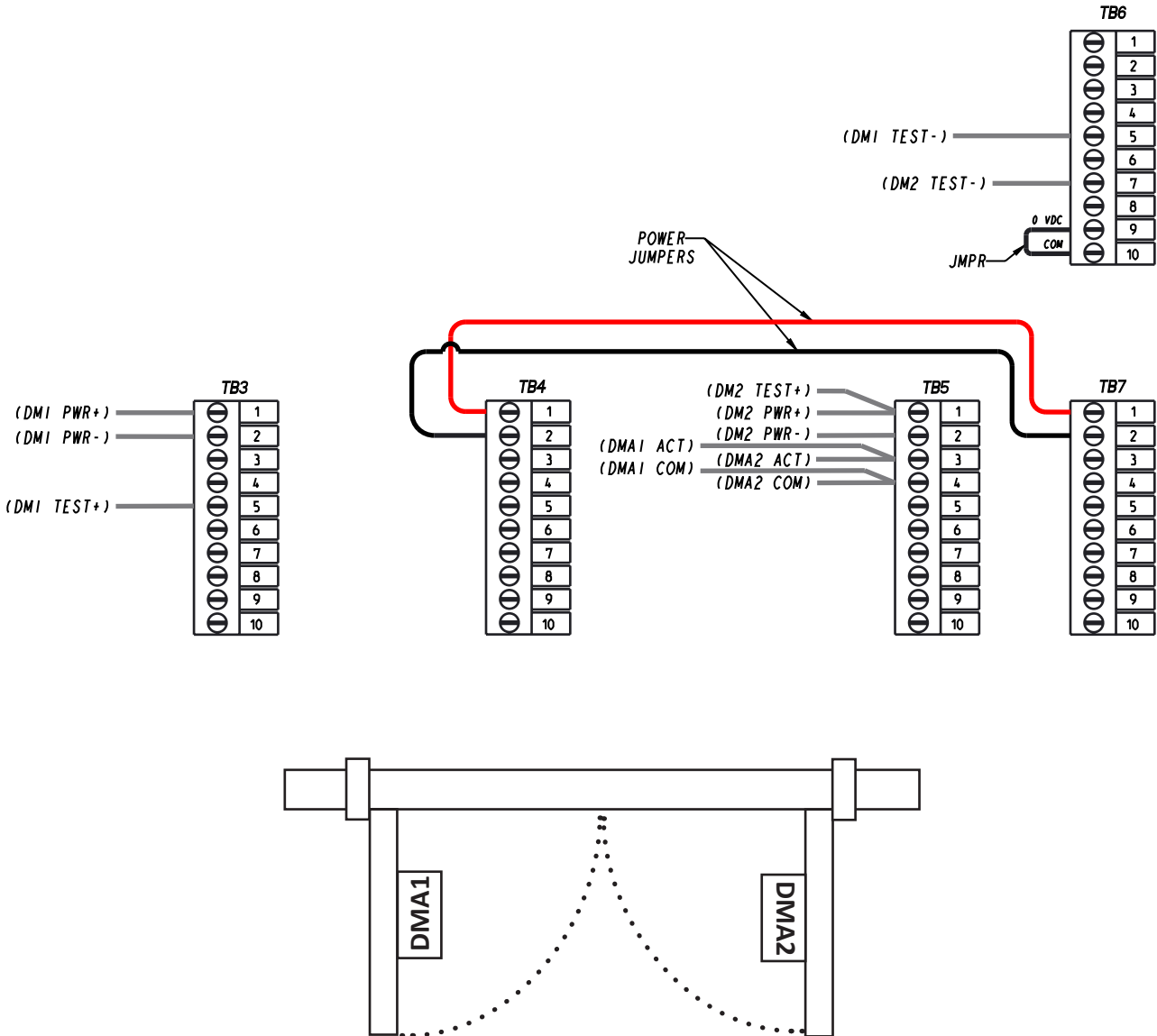

Copyright 2019, Stanley Access Technologies, LLC. All rights reserved. Reproduction in whole or in part without the express written permission of Stanley is prohibited.

10.22.2019

Attachment 4 Monitored Sensors Wiring Diagrams (Sheet 7 of 14)

OVERHEAD PRESENCE FOLDING DOOR SAFETY LOGIC - 09

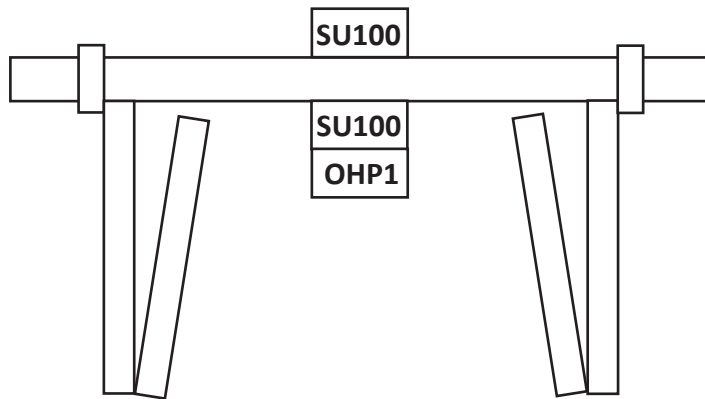
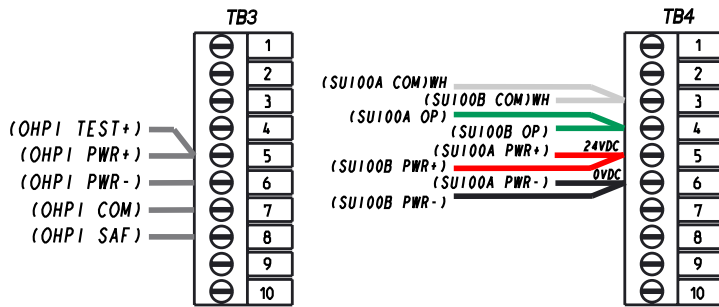
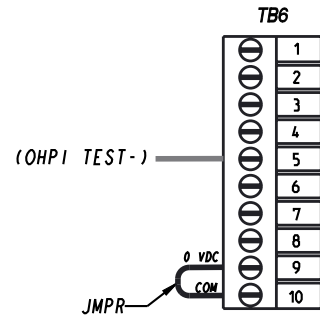
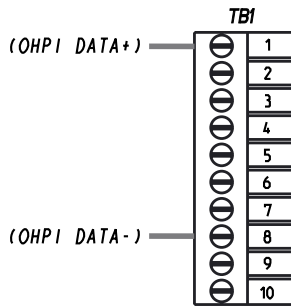

Attachment 4 Monitored Sensors Wiring Diagrams (Sheet 8 of 14)

DOOR MOUNTED STALL & ACT
SWING DOOR SINGLE
SAFETY LOGIC - 10

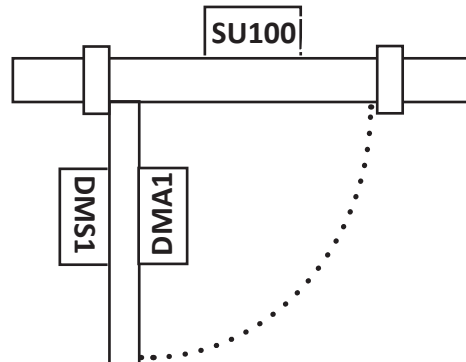
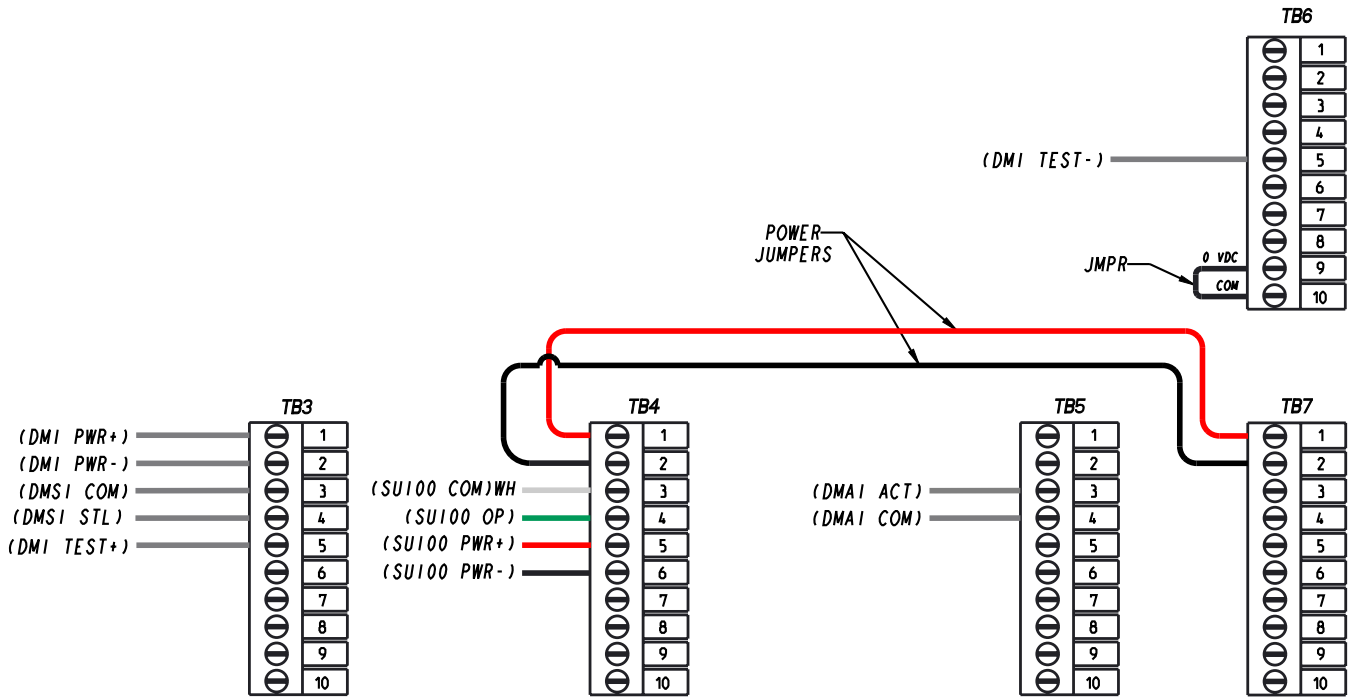

Attachment 4 Monitored Sensors Wiring Diagrams (Sheet 9 of 14)

DOOR MOUNTED STALL & ACT SWING DOOR PAIR SAFETY LOGIC - 10

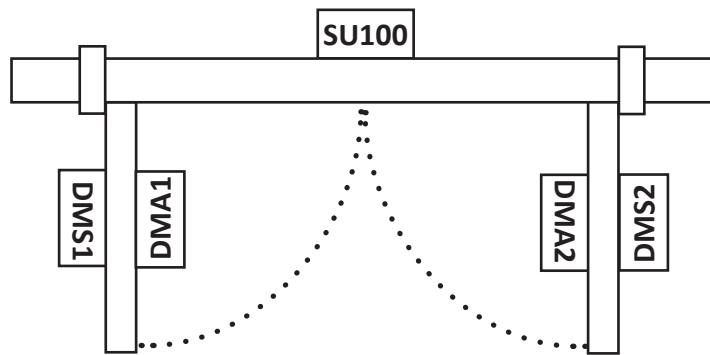
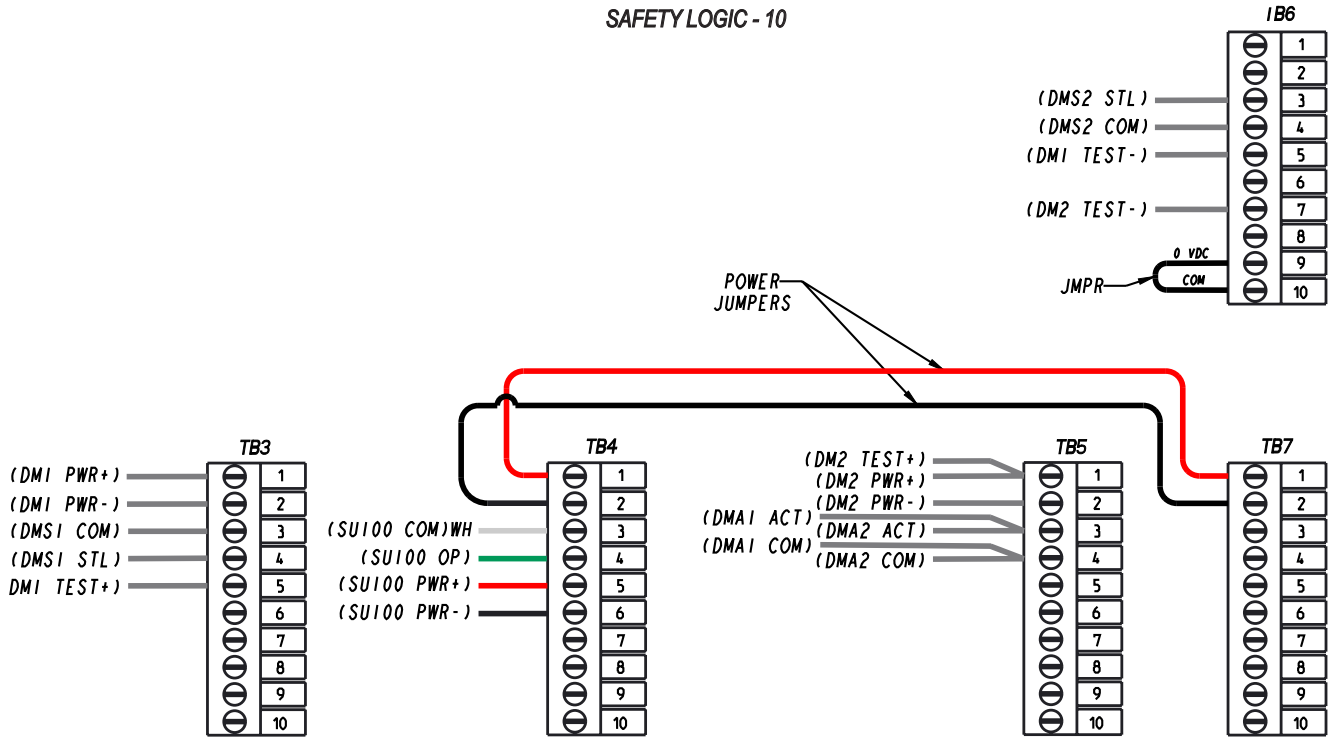

Copyright 2019, Stanley Access Technologies, LLC. All rights reserved. Reproduction in whole or in part without the express written permission of Stanley is prohibited.

10.22.2019

Attachment 4 Monitored Sensors Wiring Diagrams (Sheet 10 of 14)

TWO OVERHEAD PRESENCE FOLDING DOORS SAFETY LOGIC - 11

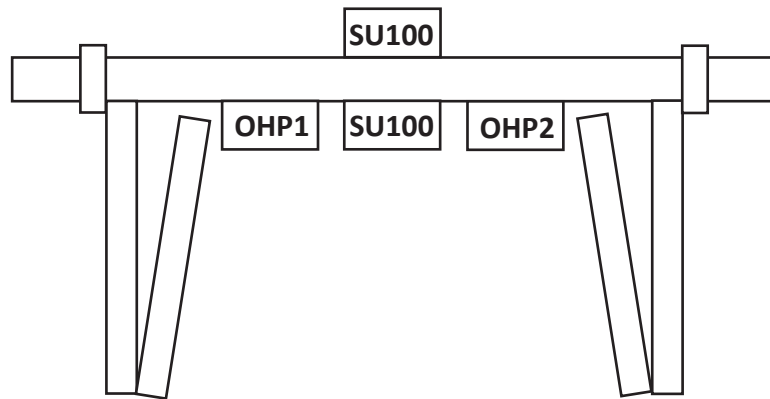
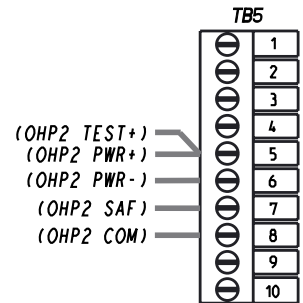
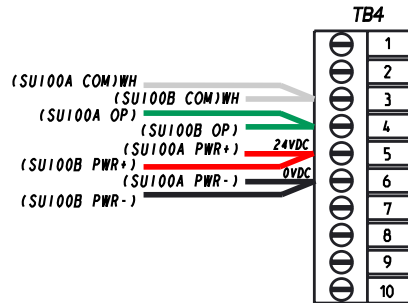
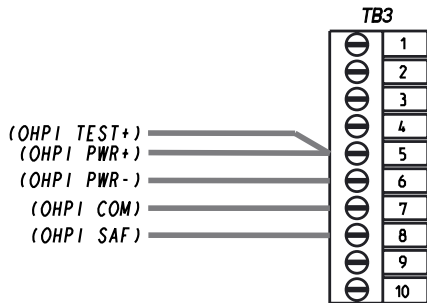
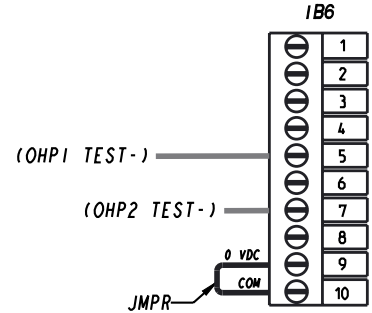
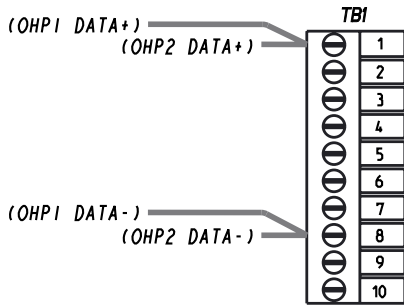

Copyright 2019, Stanley Access Technologies, LLC. All rights reserved. Reproduction in whole or in part without the express written permission of Stanley is prohibited.

10.22.2019

Attachment 4 Monitored Sensors Wiring Diagrams (Sheet 11 of 14)

HUB BASED DOOR MOUNTED STALL & ACT SWING DOOR SINGLE & PAIR SAFETY LOGIC - 12

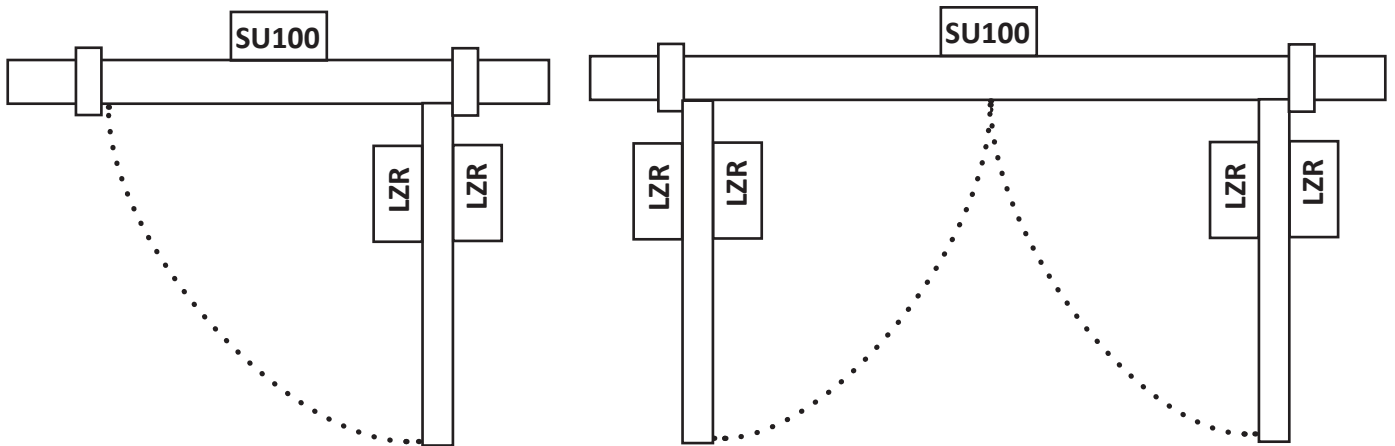
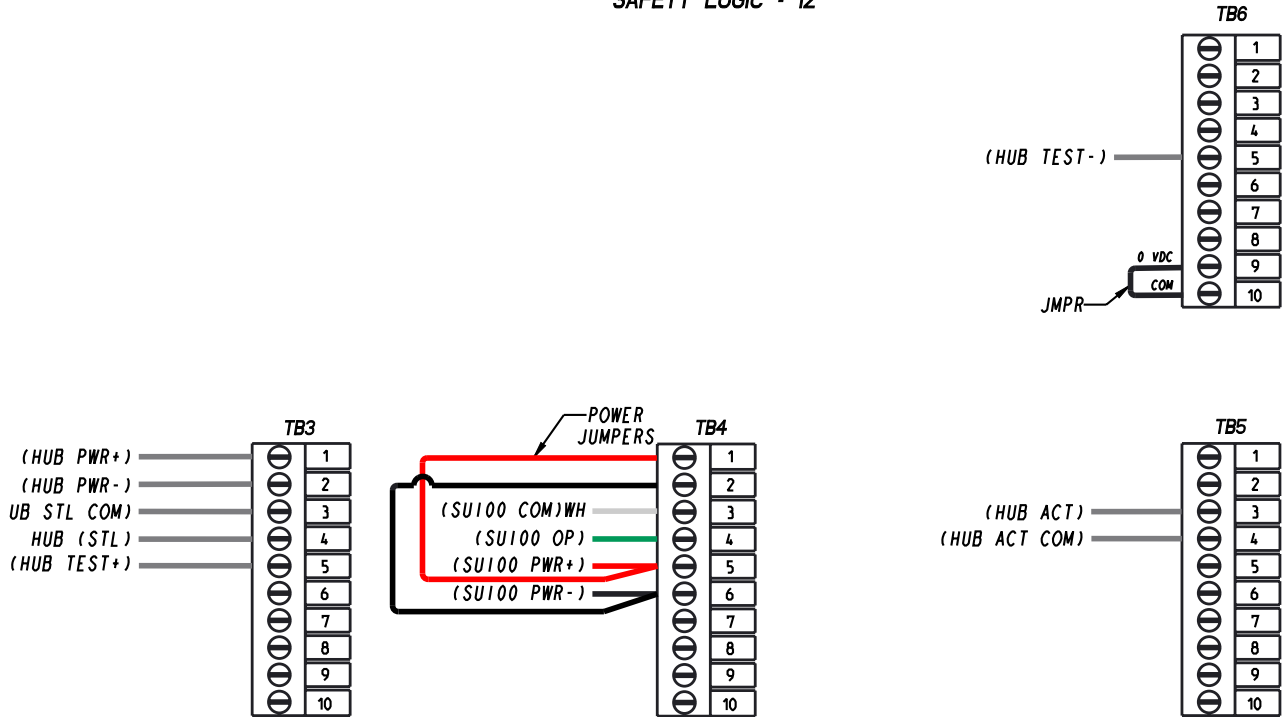

Copyright 2019, Stanley Access Technologies, LLC. All rights reserved. Reproduction in whole or in part without the express written permission of Stanley is prohibited.

10.22.2019

Attachment 4 Monitored Sensors Wiring Diagrams (Sheet 12 of 14)

**DOOR MOUNTED STALL WITH OVERHEAD PRESENCE
SWING DOOR SINGLE
SAFETY LOGIC - 14**

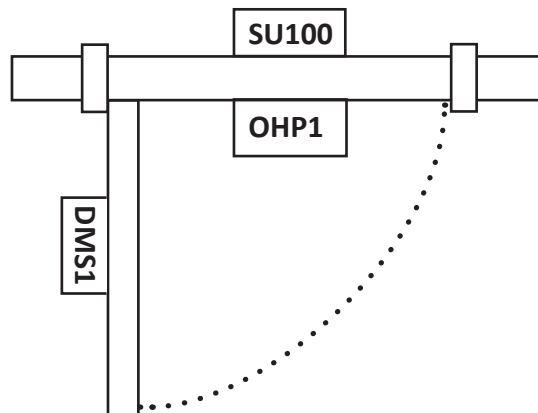
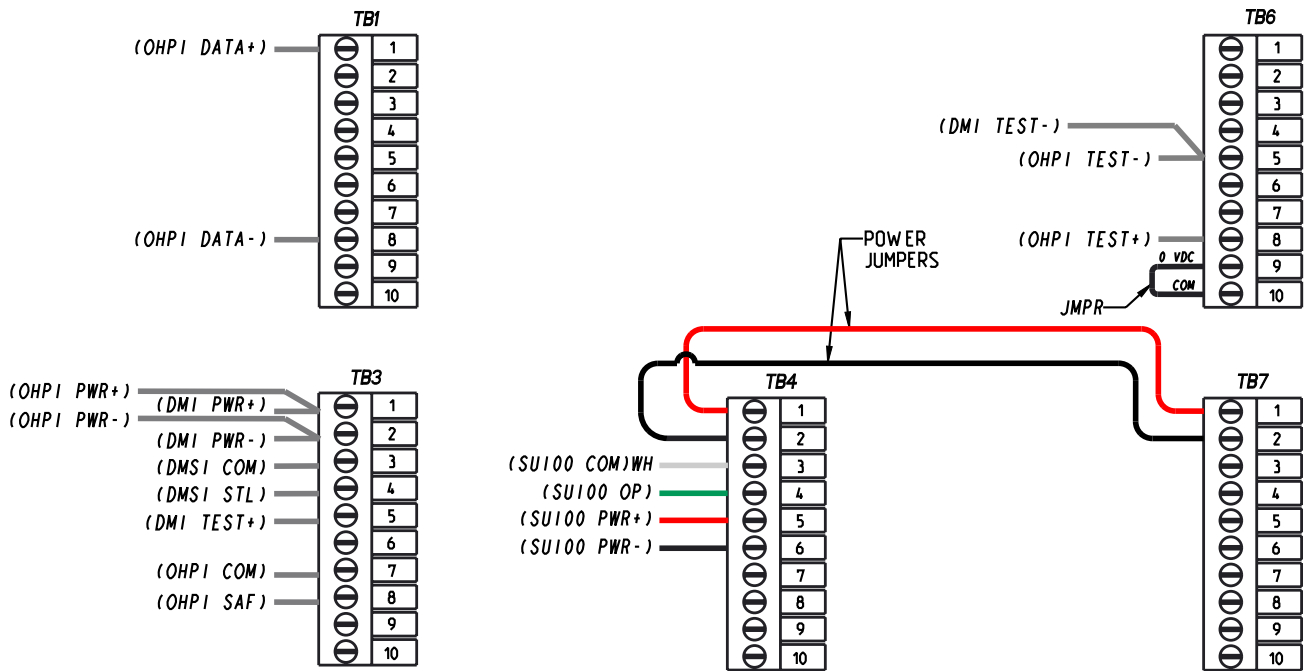

Attachment 4 Monitored Sensors Wiring Diagrams (Sheet 13 of 14)

DOOR MOUNTED STALL WITH OVERHEAD PRESENCE
SWING DOOR PAIR
SAFETY LOGIC - 14

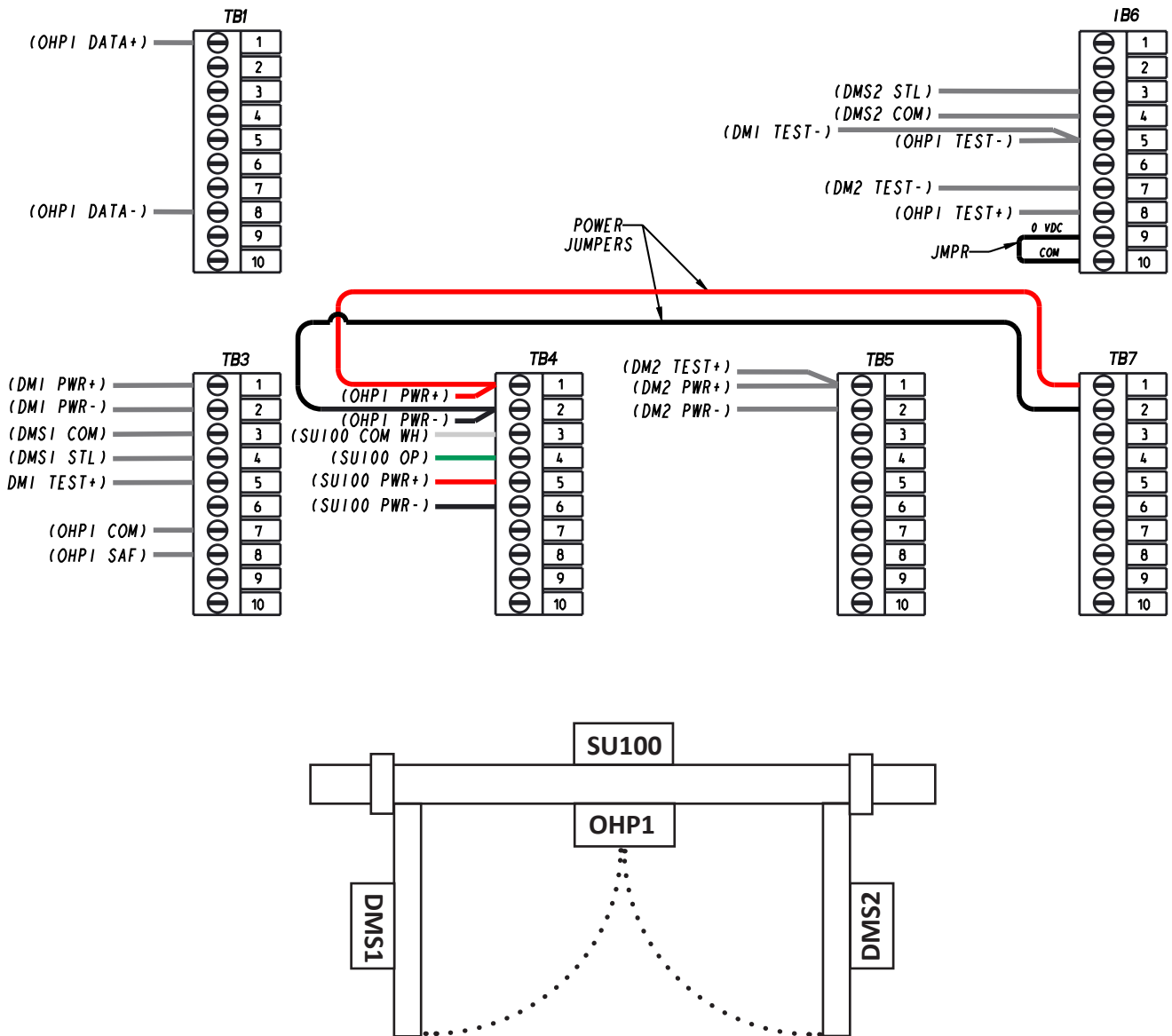

Copyright 2019, Stanley Access Technologies, LLC. All rights reserved. Reproduction in whole or in part without the express written permission of Stanley is prohibited.

10.22.2019

Attachment 4 Monitored Sensors Wiring Diagrams (Sheet 14 of 14)

DOOR MOUNTED STALL WITH TWO OVERHEAD PRESENCE
SWING DOOR DUAL EGRESS
SAFETY LOGIC - 15

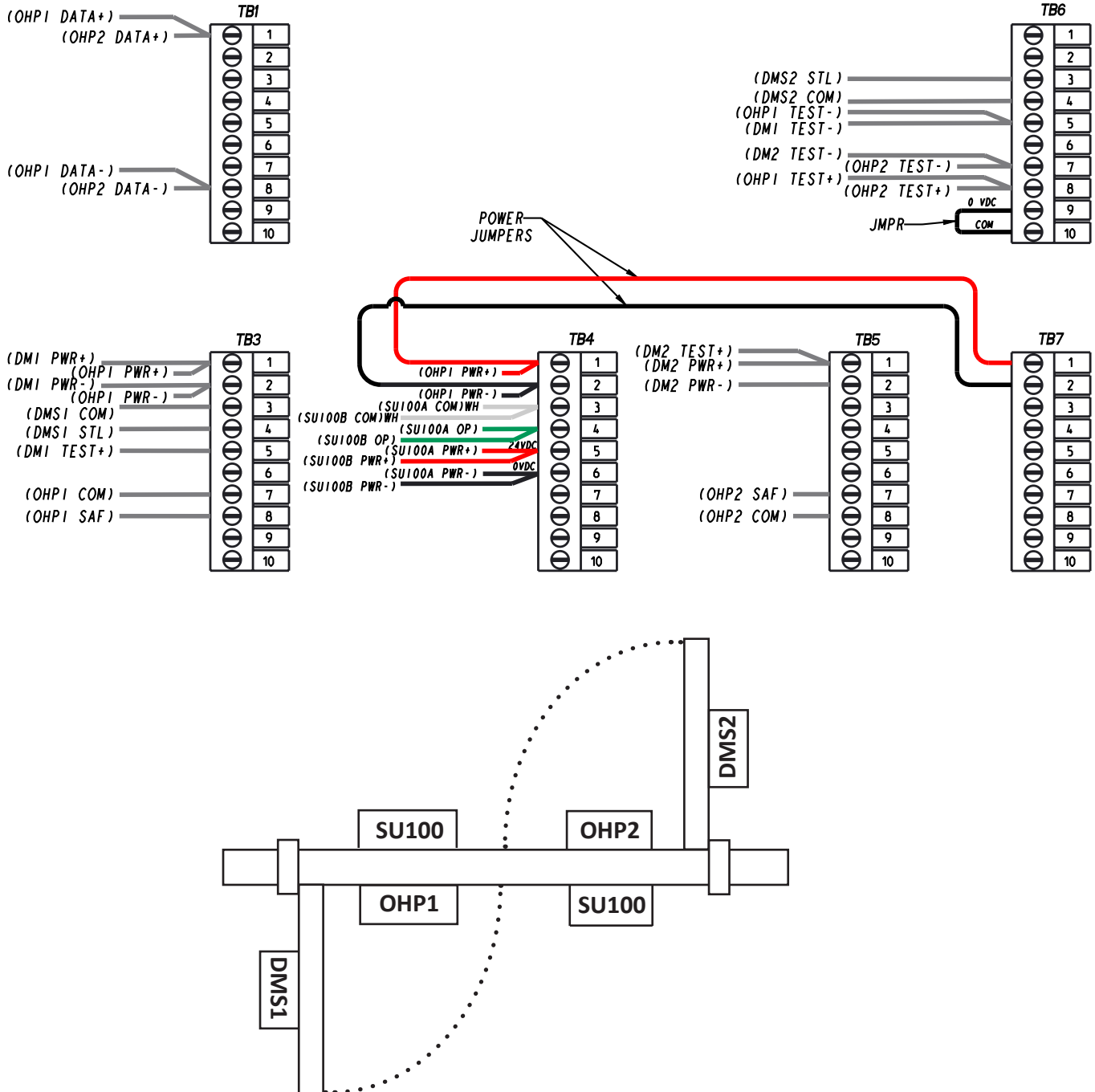

Copyright 2019, Stanley Access Technologies, LLC. All rights reserved. Reproduction in whole or in part without the express written permission of Stanley is prohibited.

10.22.2019

Attachment 5 Non-Monitored Sensors Wiring Diagrams (Sheet 1 of 3)

NOTE: This wiring is for existing installations where monitoring is NOT required.

**DOOR MOUNTED STALL & ACT WITH OVERHEAD PRESENCE
SWING DOOR SINGLE
SAFETY LOGIC - 00**

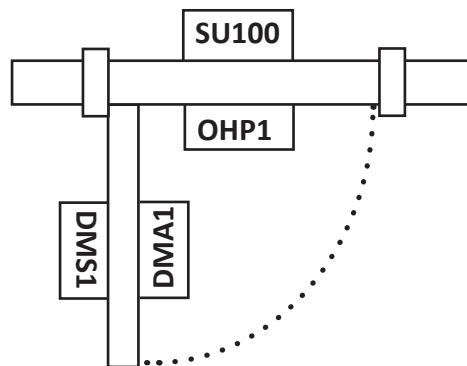
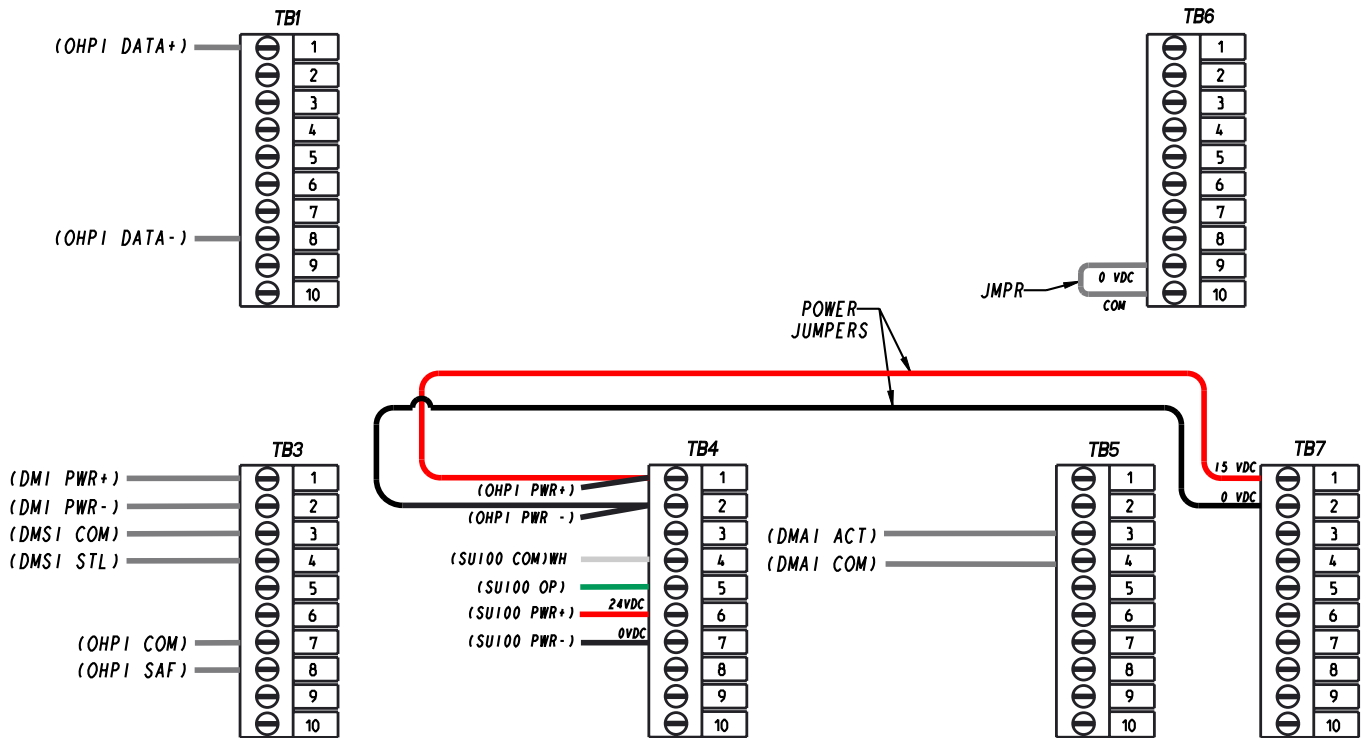

Copyright 2019, Stanley Access Technologies, LLC. All rights reserved. Reproduction in whole or in part without the express written permission of Stanley is prohibited.

10.22.2019

Attachment 5 Non-Monitored Sensors Wiring Diagrams (Sheet 2 of 3)

NOTE: This wiring is for existing installations where monitoring is NOT required.

DOOR MOUNTED STALL & ACT WITH OVERHEAD PRESENCE SWING DOOR PAIR SAFETY LOGIC - 00

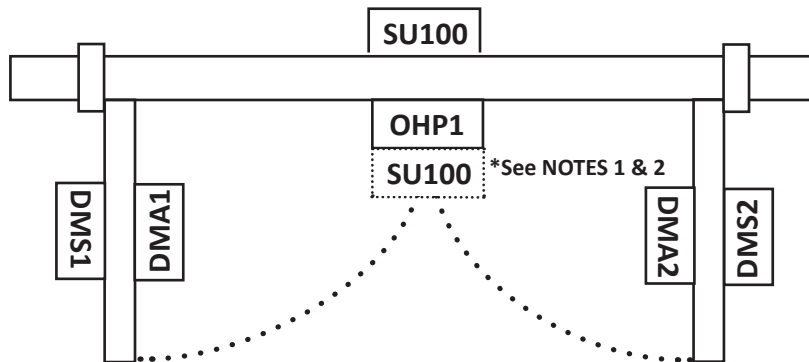
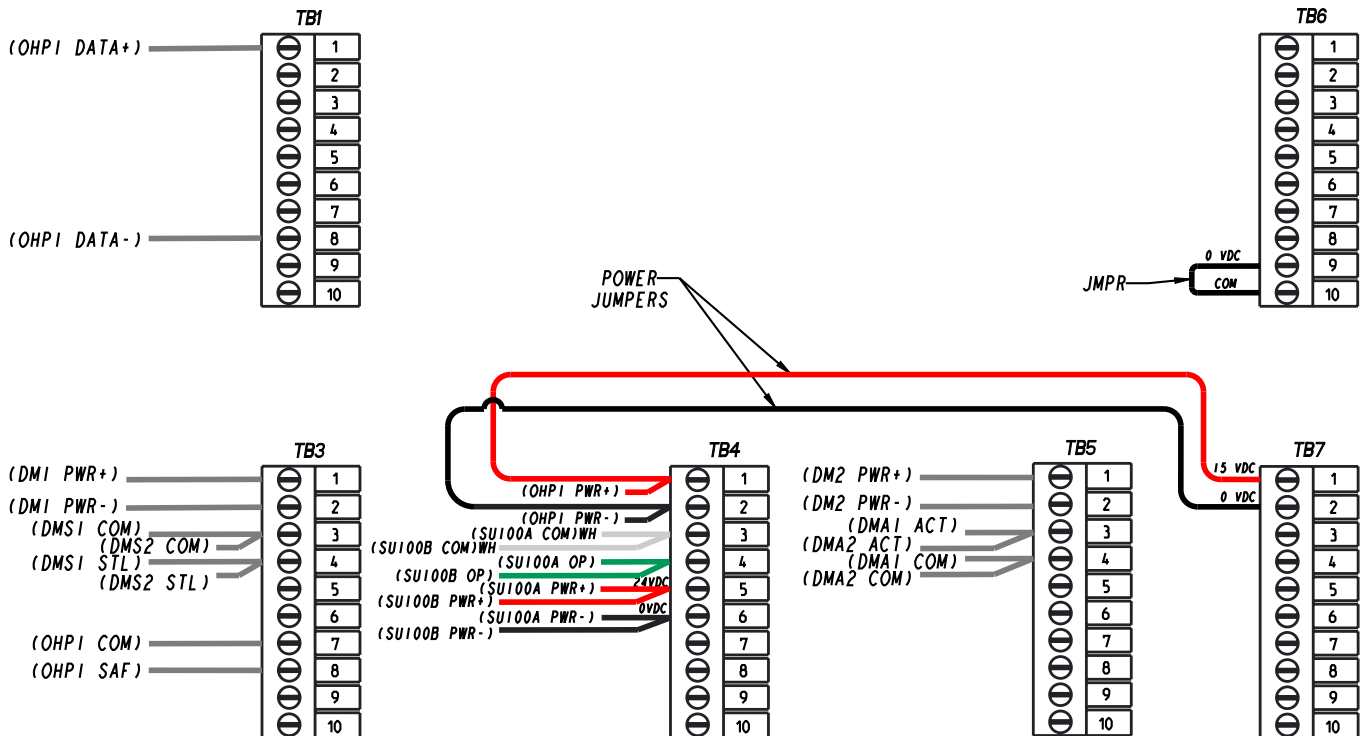

NOTES:

1. Optional SU100 for two-way traffic.
2. If the optional SU100 for two-way traffic is needed, this additional SU100 requires adding a 24VDC external power supply into TB4-1 and TB4-2 and removing the 15V power jumpers from TB7 and TB4 (see Attachment 5 sheet 3).

Attachment 5 Non-Monitored Sensors Wiring Diagrams (Sheet 3 of 3)

NOTE: This wiring is for existing installations where monitoring is NOT required.

DOOR MOUNTED STALL & ACT WITH OVERHEAD PRESENCE SWING DOOR DUAL EGRESS SAFETY LOGIC - 00

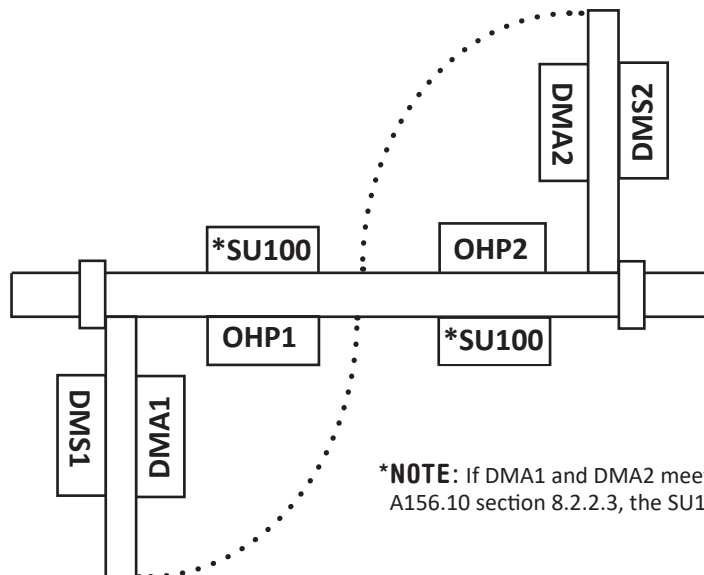
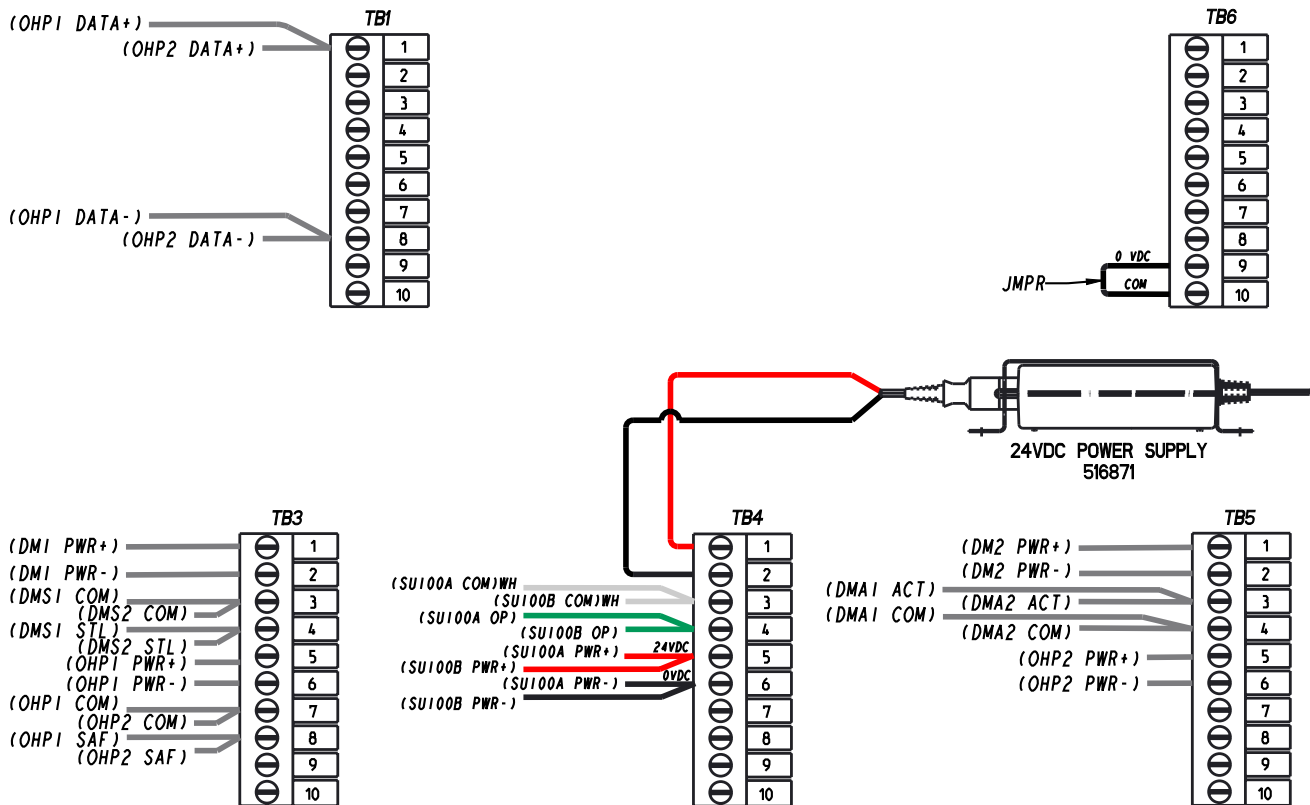

***NOTE:** If DMA1 and DMA2 meet the requirements of ANSI A156.10 section 8.2.2.3, the SU100 sensors are not required.

Attachment 6 iQ Terminal Block Connections—TB1 through TB7 (Sheet 1 of 1)

iQ CONTROLLER INPUTS AND OUTPUTS ASSIGNMENT

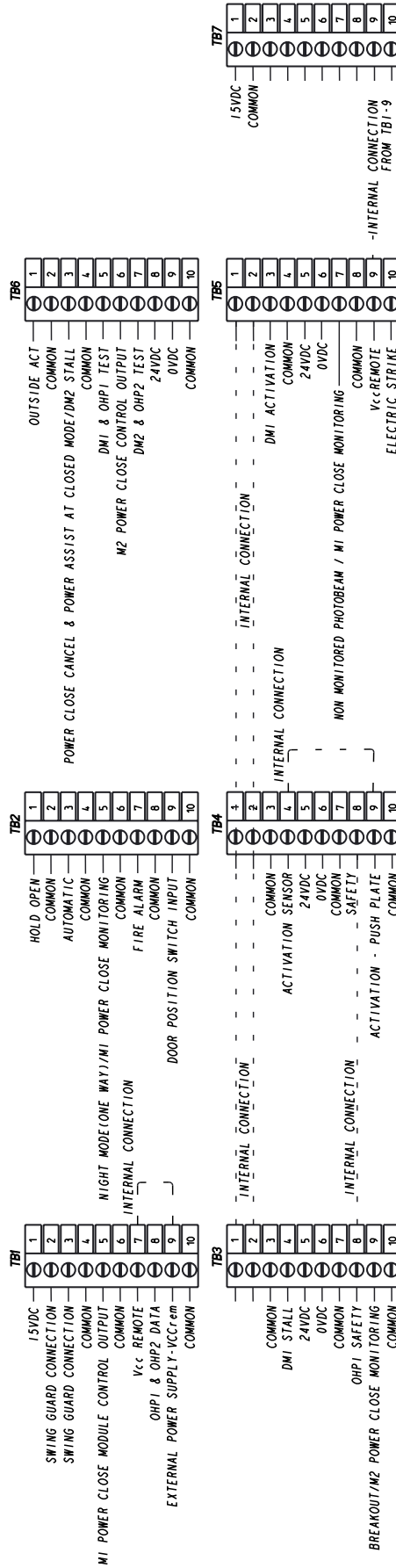

Attachment 7
iQ Controls and Indicators
(Sheet 1 of 2)

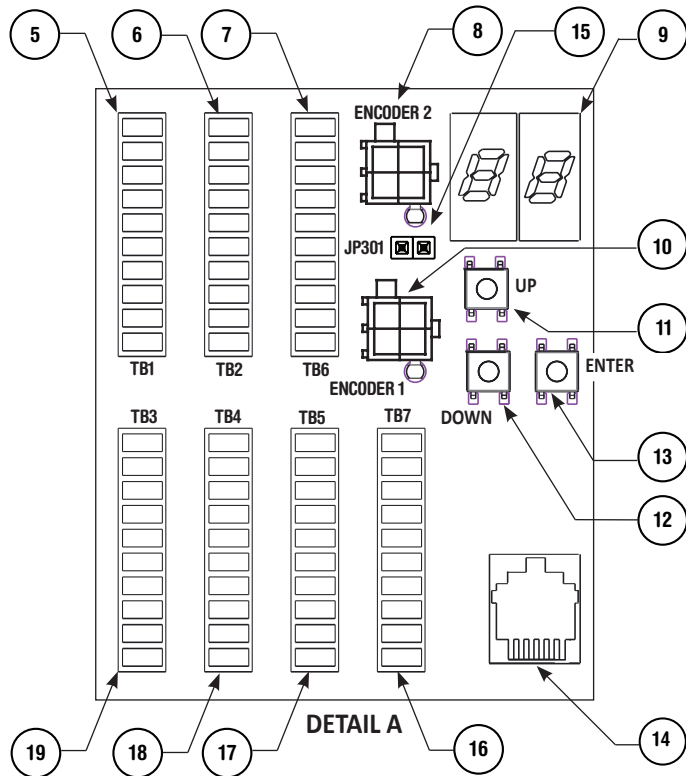
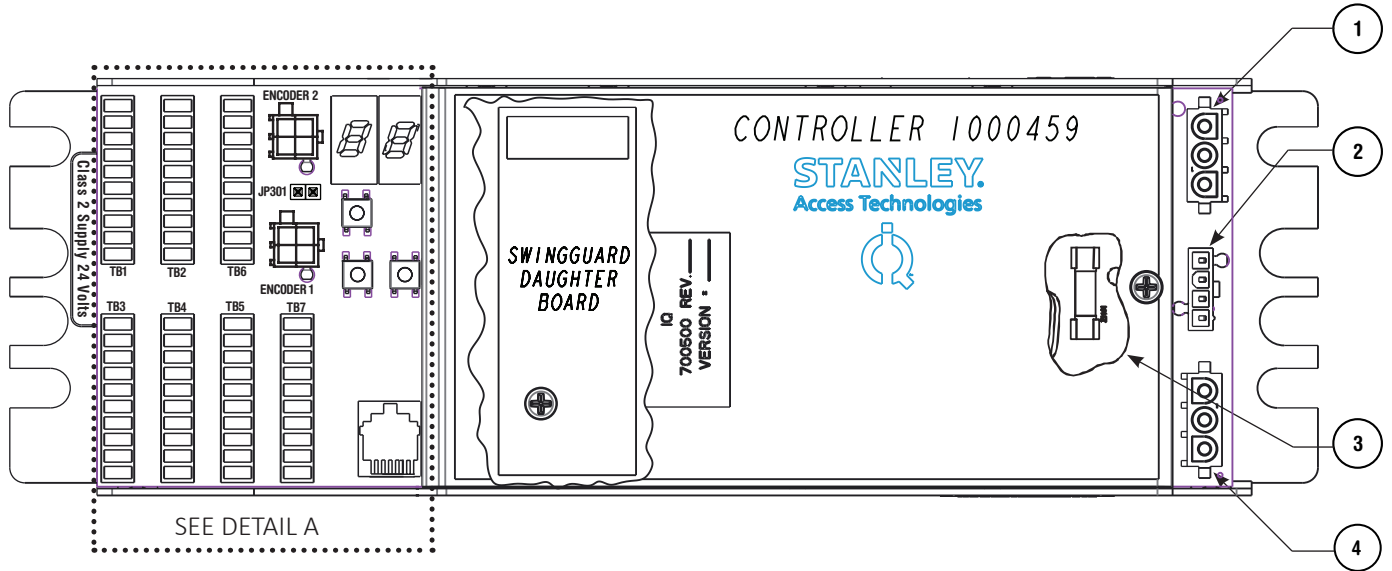

Copyright 2019, Stanley Access Technologies, LLC. All rights reserved. Reproduction in whole or in part without the express written permission of Stanley is prohibited.

10.22.2019

Attachment 7
iQ Controls and Indicators
(Sheet 2 of 2)

ITEM	CONTROL/INDICATOR	DESCRIPTION
1	Motor 2 Connector J1001	Motor No. 2 connector.
2	Power Connector J120	Connection point for incoming line, neutral, and common power wiring.
3	Fuse F1201	Controller fuse -- 5 Amp, 250V.
4	Motor 1 Connector J901	Motor No. 1 connector.
5	Terminal Block Connector TB1	Connection point for Bodyguard-T, 15VDC power supply (Swing Guard T).
6	Terminal Block Connector TB2	Connection point for function switch (rocker). Closed door function switch.
7	Terminal Block Connector TB6	Push plate outside.
8	Encoder 2 Connector J702	Encoder # 2 Connector.
9	Two Digit Display	Displays Controller Status. Also serves as the display for tune-in by pushbutton switches and indicates encoder movement.
10	Encoder 1 Connector J701	Connection point for motor encoder No. 1.
11	Up Pushbutton Switch	Used manual setup and tuning of door when hand held device is not available.
12	Down Pushbutton Switch	Used for manual setup and tuning of door when hand held device is not available.
13	Enter Pushbutton Switch	Used for manual setup and tuning of door when hand held device is not available.
14	Jack J501	COM1 connector. Connection point for Bluetooth device harness.
15	Jumper JP301	Keep jumper installed for all Swing and Fold door installations.
16	Terminal Block Connector TB7	15VDC and ECO PRO
17	Terminal Block Connector TB5	Hold Beam, Electric Strike, Swing Guard T operate signal.
18	Terminal Block Connector TB4	Connection point for operate sensor, safety sensor and push plate.
19	Terminal Block Connector TB3	Connection point for safety sensor, stall sensor, and breakout switch.

Copyright 2019, Stanley Access Technologies, LLC. All rights reserved. Reproduction in whole or in part without the express written permission of Stanley is prohibited.

10.22.2019

Attachment 8
ANSI/BHMA and UL Compliance Requirements for Swinging and Folding Doors
(Sheet 1 of 2)

Final adjustment and proper operation of the door system must be and shall be performed in the field.

NOTE: These instructions are for informational purposes and do not substitute for review against the current revision of the referenced standards. Where a requirement exists in multiple standards, such as the ANSI/BHMA standard and the UL standard, the more restrictive condition applies. Other local codes and fire codes likely exist, and must also be followed.

ANSI/BHMA A156.10 Full/Standard Power Swinging and Folding Door Systems

Full/standard power swinging and folding door systems must be installed and adjusted for compliance with the current version of ANSI/BHMA A156.10, “American National Standard for Power Operated Pedestrian Doors”.

Critical aspects of the installation for compliance with A156.10 include:

- Guide rail size, location, and type.
- Control mat size, layout, molding height, active areas and sensitivity.
- Sensor pattern size, sensitivity, and function.
- Knowing Act guidelines, secondary activating zones and double egress swing door requirements.
- Entrapment protection rules including door speeds, forces, and time delays.
- Signage. (Decals and application instructions are provided with the door operator.)

ANSI/BHMA A156.19 Low Energy Swinging Door Systems

Low energy swinging door systems must be installed and adjusted for compliance with the current version of ANSI/BHMA A156.19, “American National Standard for Power Assist and Low Energy Power Operated Doors”.

Critical aspects of the installation for compliance with A156.19 include:

- Opening times and force.
- Closing times and force.
- Manual opening force.
- Time delay.
- Signage. (Decals and application instructions are provided with the door operator.)

UL 325 Compliance

All power operated door systems must be installed in compliance with the current edition of UL 325, “Standard for Safety for Door, Drapery, Gate, Louver, and Window Operators and Systems”.

Attachment 8
ANSI/BHMA and UL Compliance Requirements for Swinging and Folding Doors
(Sheet 2 of 2)

Wiring

- To reduce the risk of electric shock proper and reliable grounding is mandatory. See **Main Power Wiring** instructions and **Wiring Diagrams** in this guide for grounding techniques.
- Permanent wiring is to be employed as required by the National Electrical Code and/or local codes.
- Connection of external devices is shown in the wiring diagrams and terminal block layouts elsewhere in this guide. Refer to these figures for proper wiring of external devices to ensure compliance with UL 325.

Knowing Act

Doors activated by a manual switch (Knowing Act switch in ANSI/BHMA terms) must have the switch installed in a location from which operation of the door can be observed by the person operating the switch.

Attachment 9
Hand Held Device Troubleshooting Aid—Swing/Fold
 (Sheet 1 of 1)

Terminal and Pin	Description	State
TB1-8	Bodyguard-T Data Output	Dark = door open Light = door closed

Function Switch States for TB2

	Hold Open	OFF	Auto ON	Night Mode
TB2-1				
TB2-3				
TB2-5				

TB1-5	M1 Power Close Module Control Output	Dark = Power Close Active
TB1-8	OHP1 and OHP Data	Dark = Door open
TB3-4	DM1 Stall	Dark = Detecting
TB3-8 and TB4-8	Safety	Dark = Detecting
TB3-9	Breakout / M2 Power Close Monitoring	Dark = No breakout
TB4-4 and TB4-9	Operate Sensor Input and Push Plate Input (connected internally)	Dark = Detecting
TB5-3	DM1 Activation	Dark = Detecting
TB5-7	Non-Monitored Photobeam / M1 Power Close Monitoring	Dark = Detecting
TB5-10	Electric Strike	Dark = On
TB6-3	Power Close Cancel and Power Assist at Closed Mode / DM2 Stall	Dark = On
TB6-5	DM1 and OHP1 Test	Dark = Normal
TB6-7	DM2 and OHP2 Test	Dark = Normal

Copyright 2019, Stanley Access Technologies, LLC. All rights reserved. Reproduction in whole or in part without the express written permission of Stanley is prohibited.

10.22.2019

Attachment 10
Recommended Values for Door Configurations
 (Sheet 1 of 1)

Description	Light Weight Door (150lbs)					
	Full Energy			Low Energy		
	Concealed	In-Swing	Out-Swing	Concealed	In-Swing	Out-Swing
Open Learn Speed	20	20	20	15	15	15
Open Learn Torque	60	50	60	35	30	35
Open Startup Torque	60	40	60	40	30	40
Open Startup Length	5	5	5	10	10	10
Open Speed	65	106	70	32	46	33
Open Torque	60	40	60	35	20	35
Open Acceleration	10	12	10	20	12	20
Open Check Length	45	40	35	20	23	20
Open Check Speed	6	10	7	10	10	6
Open Check Torque	60	60	60	35	35	35
Open Braking	2	10	10	2	6	9
Open Stop	30	30	30	20	30	30
Open Check Recycle Speed	45	45	45	45	45	45

Attachment 10
Recommended Values for Door Configurations

Description	Heavy Weight Door (350lbs)					
	Full Energy			Low Energy		
	Concealed	In-Swing	Out-Swing	Concealed	In-Swing	Out-Swing
Open Learn Speed	20	20	20	15	15	15
Open Learn Torque	60	50	60	35	30	35
Open Startup Torque	60	35	60	40	25	40
Open Startup Length	5	5	5	10	10	10
Open Speed	47	108	56	32	42	20
Open Torque	60	40	60	35	20	35
Open Acceleration	15	30	10	20	20	20
Open Check Length	45	45	36	25	25	20
Open Check Speed	10	3	12	6	10	6
Open Check Torque	60	60	60	35	35	35
Open Braking	1	4	10	2	8	2
Open Stop	40	20	30	40	30	30
Open Check Recycle Speed	55	45	45	45	45	45
Overspeed Resistance	25	25	25	25	25	25

Copyright 2019, Stanley Access Technologies, LLC. All rights reserved. Reproduction in whole or in part without the express written permission of Stanley is prohibited.

10.22.2019

Attachment 11
iQ Controller Fine Tuning
 (Sheet 1 of 1)

Match your actual door to one from the list of doors described in Attachment 10. Start by installing these settings. Use the guide below to make adjustments to these settings.

SWING DOOR:

SYMPTOM	RECOMMENDED SOLUTION
Door opens too slowly.	<ol style="list-style-type: none"> 1. Increase Open Speed². 2. Increase Open Torque^{1,2}. 3. Increase Open Acceleration.
Door closes too slowly.	<ol style="list-style-type: none"> 1. Adjust Close Speed Module or Power Close Speed Module². 2. Check for mechanical binding.
Door hits the open stop too hard.	<ol style="list-style-type: none"> 1. Increase Open Check Length until door slows down a considerable distance from the Open Stop. 2. Increase Open Braking until the door slows down into Open Check. 3. Decrease Open Check Speed if door speeds up after slowing down into Open Check. 4. Increase Open Stop until door no longer hits the open stop.
Door stalls while opening without any mechanical reason.	<ol style="list-style-type: none"> 1. Increase Open Obstruction Time and/or Open Check Obstruction Time. 2. Make small increases to Open Torque¹ and/or Open Check Torque.
Door creeps closed from full open.	<ol style="list-style-type: none"> 1. Increase Stall Torque one count at a time until the open position is stable. 2. To verify new setting, door must be cycled open and return to full closed.

NOTES:

1. **Open Torque** is also used to set the door open force.
2. **Open / Close Speeds** and **Forces** must comply with UL and ANSI/BHMA A156.19 or 156.10 requirements.

Copyright 2019, Stanley Access Technologies, LLC. All rights reserved. Reproduction in whole or in part without the express written permission of Stanley is prohibited.

10.22.2019

Stanley Access Technologies, LLC.
65 Scott Swamp Road
Farmington, CT 06032