



# TECH TIP

## Industrial Slider IS10000 Manual Revision E

Prepared by: Jeff Bonas

Engineer: Kevin Fitzgibbons

Tech Tip: TT050810

PCN: 05-15c, 05-82b

RDW: \_\_\_\_\_

Reference Tech Tip: \_\_\_\_\_

Engineering Document Number: \_\_\_\_\_

### Summary Information

#### Product Information

- Bifold
- Slide
- Swing
- Class 2
- Accessories
- Controls
- Operators / Drives
- Panels / Hardware
- Sensors

#### Tech Tip Classification

- Adjustment
- Installation
- Customer Complaints
- Clarifications
- FAQs
- Service
- Retrofit/Upgrade Instructions
- Design Change Description

#### Release Action

- Level 1 - Does not impact maintenance or operation of door. (Only Safety/Liability and Engineering need to sign.)
- Level 2 - Full sign off required.

#### Release Information (initial and date)

Safety/Liability \_\_\_\_\_

Engineering \_\_\_\_\_

Technical Support \_\_\_\_\_

Field Operations \_\_\_\_\_

Quality \_\_\_\_\_

If you have any questions concerning this procedure, contact Access Technologies Technical Support, at 1-800-422-6489 Option 3.



## TECH TIP

---

---

# Industrial Slider IS10000 Manual Revision E

---

---

Prepared by: Jeff Bonas

Engineer: Kevin Fitzgibbons

Tech Tip: TT050810

### Action Required

- Replacement Required     None, Information Only     Inspection Required     Where Symptom Exists     New Installation Only  
 Inspect During Maintenance

Attached is manual IS10000 Sliding Door, Installation Instructions, Quick-Reference Guide, 203913, Rev. E, 6/28/05. This manual has been revised to add information about the new Wind Kits.

The changes can be found in the following locations:

Page 2, Section 1.3, Bullet 3, Added friction rollers on the fast panel lead edges.

Page 2, Section 1.3, Bullet 10, Added Wind kit.

Page 4, Section 4.3.1, and Figure 1, Changed height of upper header mounting plate holes.

Page 14, Section 4.8, Added Wind Kit.

Stanley Access Technologies  
**Installation and Operating Manual**



**IS 10000 Sliding Door  
Installation Instructions  
Quick-Reference Guide  
203913  
Rev. E, 6/28/05**

**Prohibition on Copying**

Any unauthorized reproduction, disclosure or distribution of copies by any person of any portion of this work may be a violation of copyright law of the United States of America and other countries, could result in the awarding of statutory damages of up to \$250,000 (17 USC 504) for infringement, and may result in further civil and criminal penalties. All rights reserved.

**Installation and Operating Manual**

TABLE OF CONTENTS

1. PURPOSE.....	2
1.1 Discussion.....	2
1.2 Applicability.....	2
1.3 Features and Functions.....	2
2. PREREQUISITES.....	3
3. PRECAUTIONS.....	3
4. INSTALLATION INSTRUCTIONS.....	4
4.1 Preinstallation Meeting.....	4
4.2 Checking the Rough Opening.....	4
4.3 Installing the Header.....	4
4.4 Mounting the Sensors.....	8
4.5 Installing the Switch Box.....	10
4.6 Installing the Slow Panels.....	10
4.7 Installing the Fast Panels.....	12
4.8 Installing the Slow Panel Floor Guide Track.....	14
4.9 Installing the Reversing Cable.....	16
4.10 Installing the E-Chain Brackets.....	17
4.11 Installing and Adjusting the Motor Belt.....	18
4.12 Installing the Weatherstripping.....	18
4.13 Installing the Doorway Holding Beam Door Position Switch.....	20
4.14 Tune-In and Adjustment.....	20
4.15 Closeout Procedure.....	20
4.16 Replacement Parts.....	20

Attachments

Attachment 1, Documents, Definitions, Special Tools, Equipment, Materials, and Consumables.....	21
Attachment 2, Masonry Opening.....	22
Attachment 3, System Wiring Diagram.....	23
Attachment 4, Replacement Parts.....	29

## 1. PURPOSE

### 1.1 **Discussion**

This manual provides installation instructions and a replacement parts listing for the Stanley IS 10000 automatic sliding door system. The IS 10000 is a heavy-duty telescoping sliding door package used in industrial and large retail-type operations. The synchronized doors can open wide to accommodate forklifts and other large equipment or open narrow to provide pedestrian passage.

### 1.2 **Applicability**

This manual is applicable to the Stanley IS 10000 automatic sliding door. Instructions for installing optional accessories such as key switches, door alarm contacts, push plates, and door position switches are provided in separate installation manuals. This manual does not cover components installed by other companies.

### 1.3 **Features and Functions**

1.3.1 The IS 10000 sliding door includes the following features and functions:

- Surface installation on the outside or inside of the building
- Heavy duty control and extra motor gearbox
- Friction rollers on the fast panel lead edges
- Welded panels
- Eight-laminate hook lock and armored strike
- Toggle door operating switch
- SU-100 motion sensors (six required—three on each side)
- Optex OA-203C infrared presence sensors (four required—two on each side)
- Doorway holding beams (two pairs required for fast panels—upper and lower)
- Wind kit

## 2. PREREQUISITES

- 2.1.1 Finished walls have been installed.
- 2.1.2 Protective barrier (caution/warning tape) has been set up to prevent unauthorized access to work area.
- 2.1.3 The packing list has been reviewed, and all required parts are included.
- 2.1.4 The area has been cleared of all obstructions.
- 2.1.5 The steel beam has been installed to accommodate mounting of the header.
- 2.1.6 Attachment 1 has been reviewed for the following:
  - Definitions of the terms used in this procedure
  - A listing of the documents, special tools and equipment, materials, and consumables used in this procedure.
- 2.1.7 Attachment 2 has been reviewed to ensure that there is adequate clearance for the following:
  - Opening the door fully.
  - Installing the header.

## 3. PRECAUTIONS

- 3.1.1 The header and door panels are very heavy. Extreme caution must be used during installation. Two technicians and a power manlift are required to install this door package.
- 3.1.2 A licensed electrician is required to install conduit and bring high- and low-voltage supply wiring from the header to the switch box. Electrician is also responsible for grounding the switch box and both sides of the header using the ground straps provided.
- 3.1.3 When testing or operating doors, make certain there are no obstructions in the path of the panels.

#### 4. INSTALLATION INSTRUCTIONS

##### 4.1 **Preinstallation Meeting**

4.1.1 CONSULT with the Store Manager on site regarding the following:

- VERIFY availability of electrician on the second day of installation.
- DISCUSS the scope of electrician's duties outlined in paragraph 3.2.
- DETERMINE the desired location for the switch box.

##### 4.2 **Checking the Rough Opening**

4.2.1 SWEEP floor.

4.2.2 Using a surveyor's transit, PERFORM the following:

- a. CHECK the floor across the entire opening, and DETERMINE the highest and lowest points of the floor.
- b. CALCULATE the difference in height between the highest and lowest points of the floor.

4.2.3 CHECK the opening width.

4.2.4 Refer to Attachment 2, and DETERMINE if the masonry opening will accommodate the door package.

##### 4.3 **Installing the Header**

#### **NOTE**

The header mounting plate holes must be located from the *highest point* on the finished floor.

4.3.1 Refer to Figure 1 and Attachment 2, and, using door stile length and header mounting plate as a guide, DETERMINE header mounting plate hole locations on steel beam as follows:

- The location of the *upper* header mounting plate holes from the highest point of the floor is 130" (+0.250", -0.00").
- The location of the *lower* header mounting plate holes is 6" lower than the upper header mounting plate holes.

**Figure 1. Hole Locations for the Header Mounting Plate**

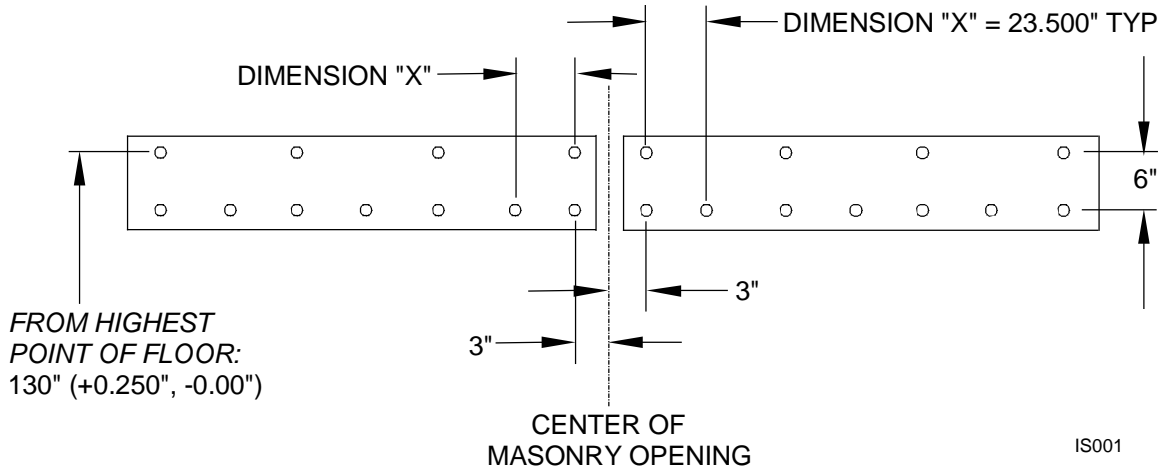

- 4.3.2 Using the holes in the slow track as a guide, DRILL  $\frac{5}{16}$ " mounting holes through the front of the steel beam at the marked locations.
- 4.3.3 TAP the holes for  $\frac{3}{8}$ "-16 bolts.
- 4.3.4 Refer to Figure 2 and, using the  $\frac{3}{8}$ "-16 x 1" bolts supplied, FASTEN the header mounting plate to the steel beam.

**Figure 2. Installing the Header Mounting Plate**

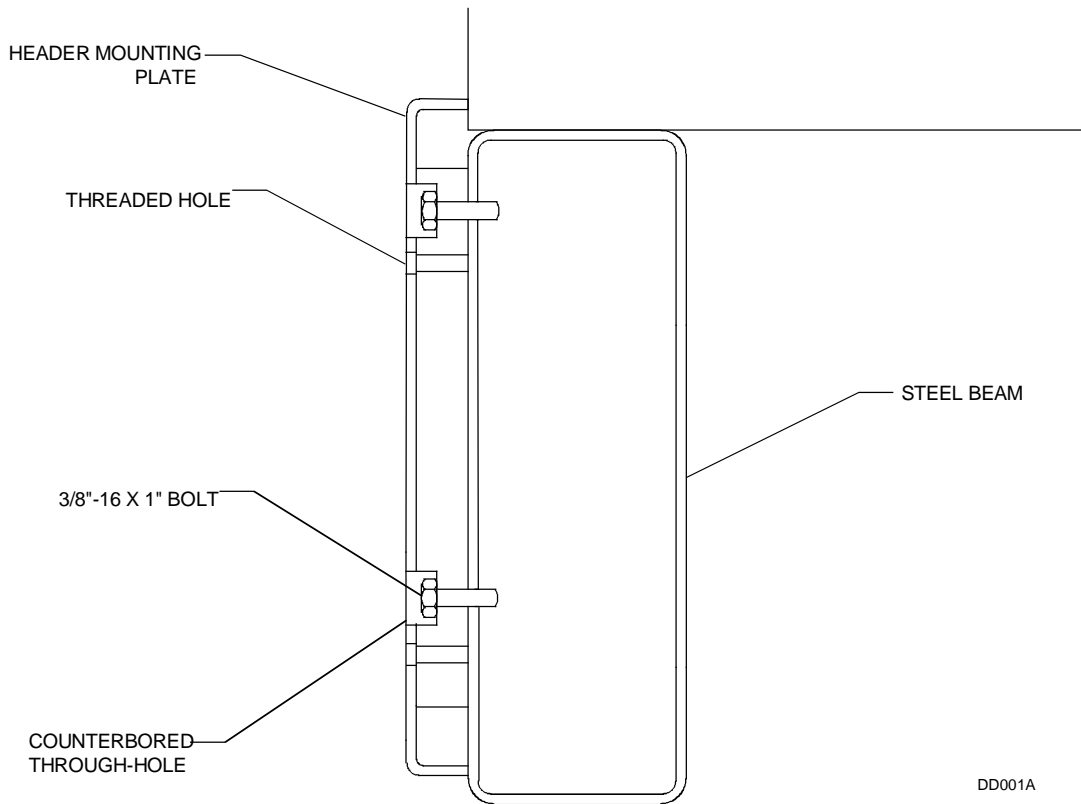



- 4.3.5 Refer to Figure 3, and, using the  $\frac{3}{8}$ "-16 x 1" bolts supplied, FASTEN both slow track extrusions to the header mounting plate.

**Figure 3. Installing the Slow Track Extrusion onto the Header Mounting Plate**

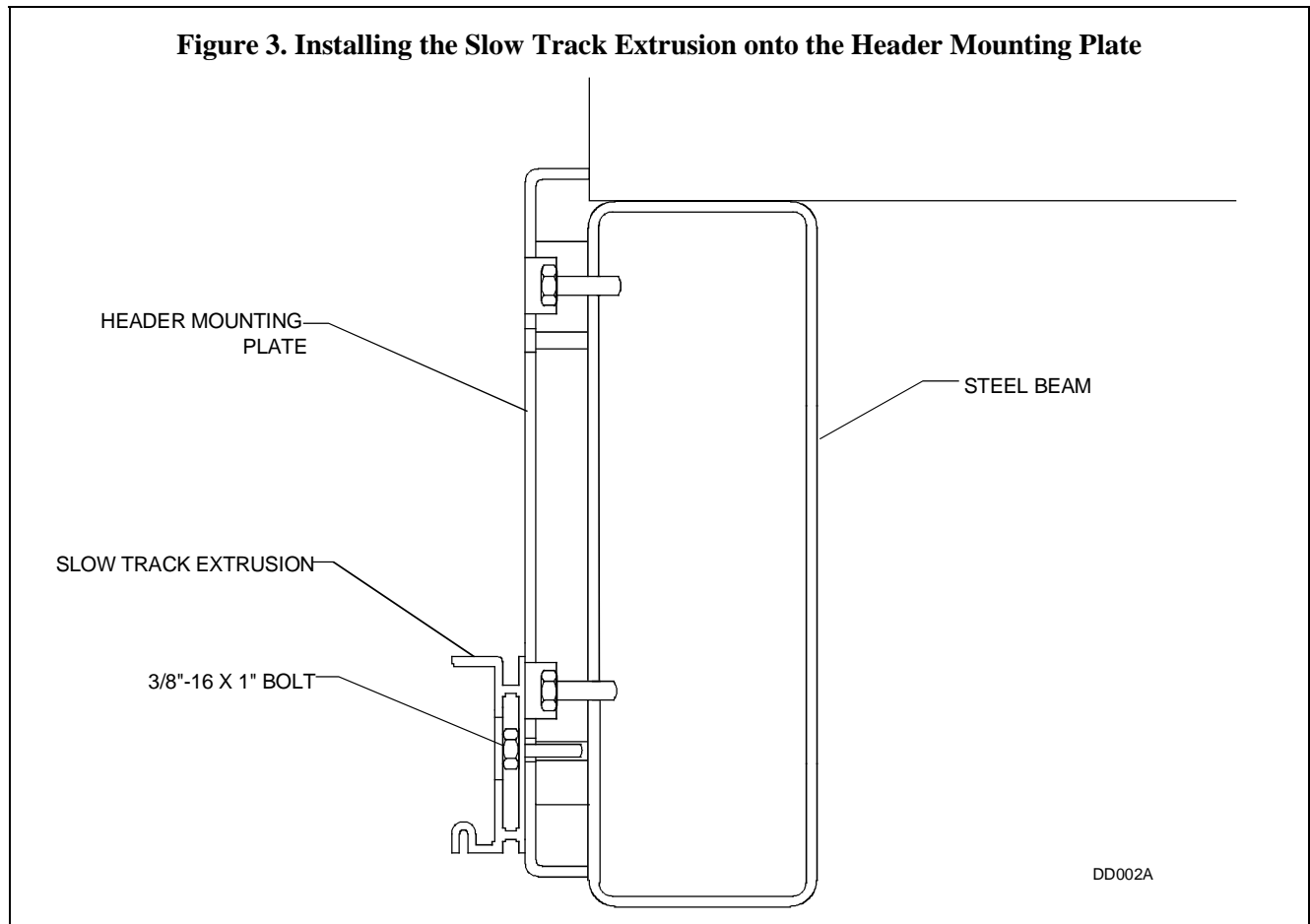

**NOTE**

If the slow track extrusion must be shimmed, install the shims so that they extend into the header area. This will allow the header to be mounted against the shims.

- 4.3.6 Using a line level stretched the length of the header mounting plate, ENSURE the slow track extrusion is level and *not* twisted or bowed. SHIM the slow track extrusion as necessary.

## NOTE

Typically, the header covers are installed *after* the headers have been mounted. When the installation site does *not* provide enough space to the left and right of the MO, the header covers must be installed *before* mounting the header.

- 4.3.7 MEASURE the space to the left and right of the header mounting location.
- 4.3.8 IF necessary, INSTALL header covers.
- 4.3.9 Refer to Figure 4, and POSITION the LH header above the slow track extrusion.

**Figure 4. Installing the Header onto the Header Mounting Plate**

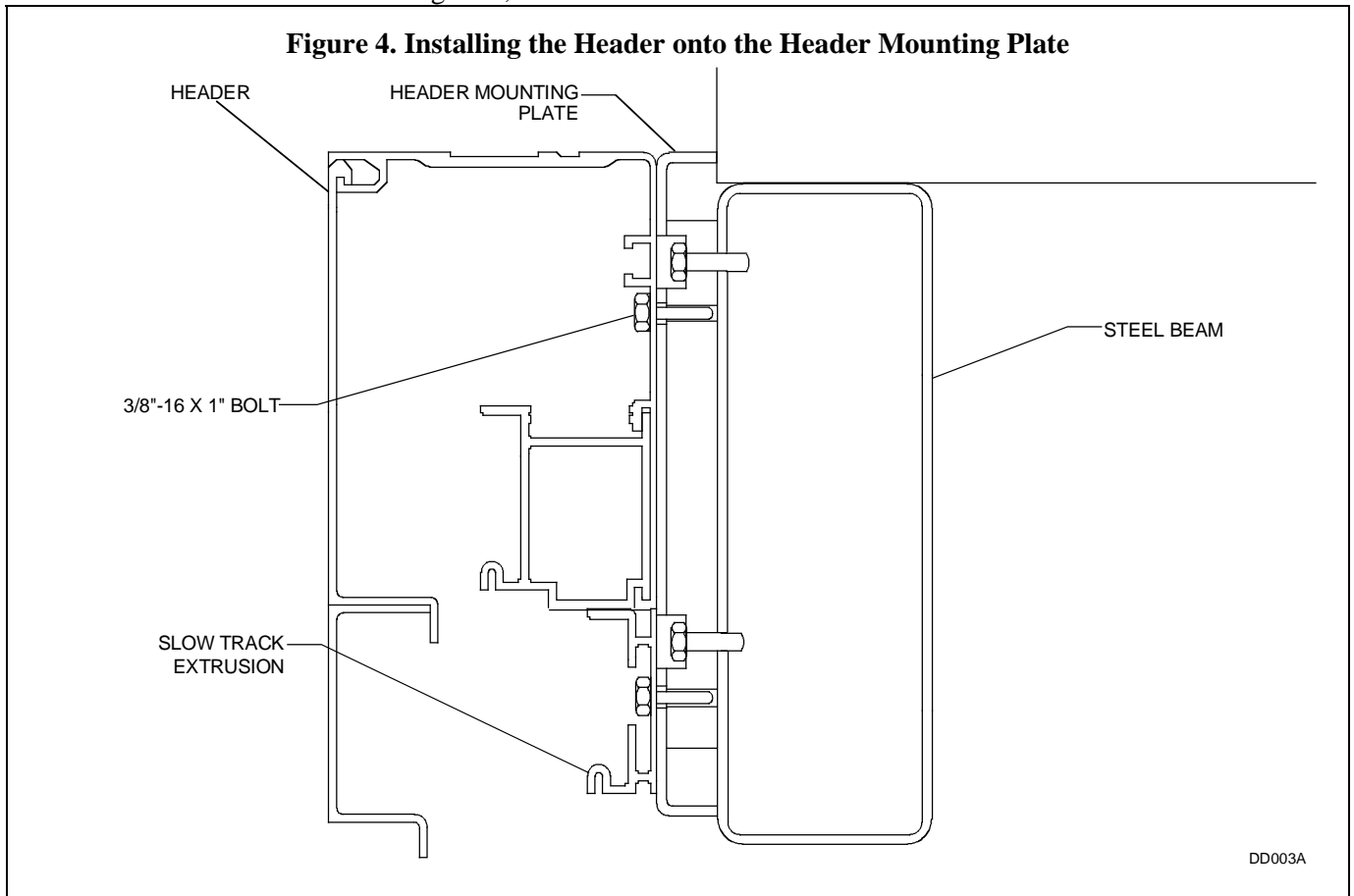

- 4.3.10 Using the  $\frac{3}{8}$ "-16 x 1" bolts supplied, FASTEN the LH header to the header mounting plate.
- 4.3.11 REPEAT steps 4.3.9 and 4.3.10 for the RH header.
- 4.3.12 Using a line level stretched the length of the header mounting plate, ENSURE the headers are level and not twisted or bowed. SHIM as necessary.
- 4.3.13 Using  $\frac{1}{4}$ "-20 x  $1\frac{1}{2}$ " bolts, FASTEN the header center bracket to the headers.
- 4.3.14 Using kit 516397, FASTEN the endcap dress plates to the headers.

## 4.4 Mounting the Sensors

### NOTE

Six SU-100 motion sensors are required—three on the header side and three on the non-header side. Four Optex OA-203C infrared presence sensors are required—two on the header side and two on the non-header side.

4.4.1 Refer to Figure 5, and **INSTALL** header-side sensors onto the header cover as follows:

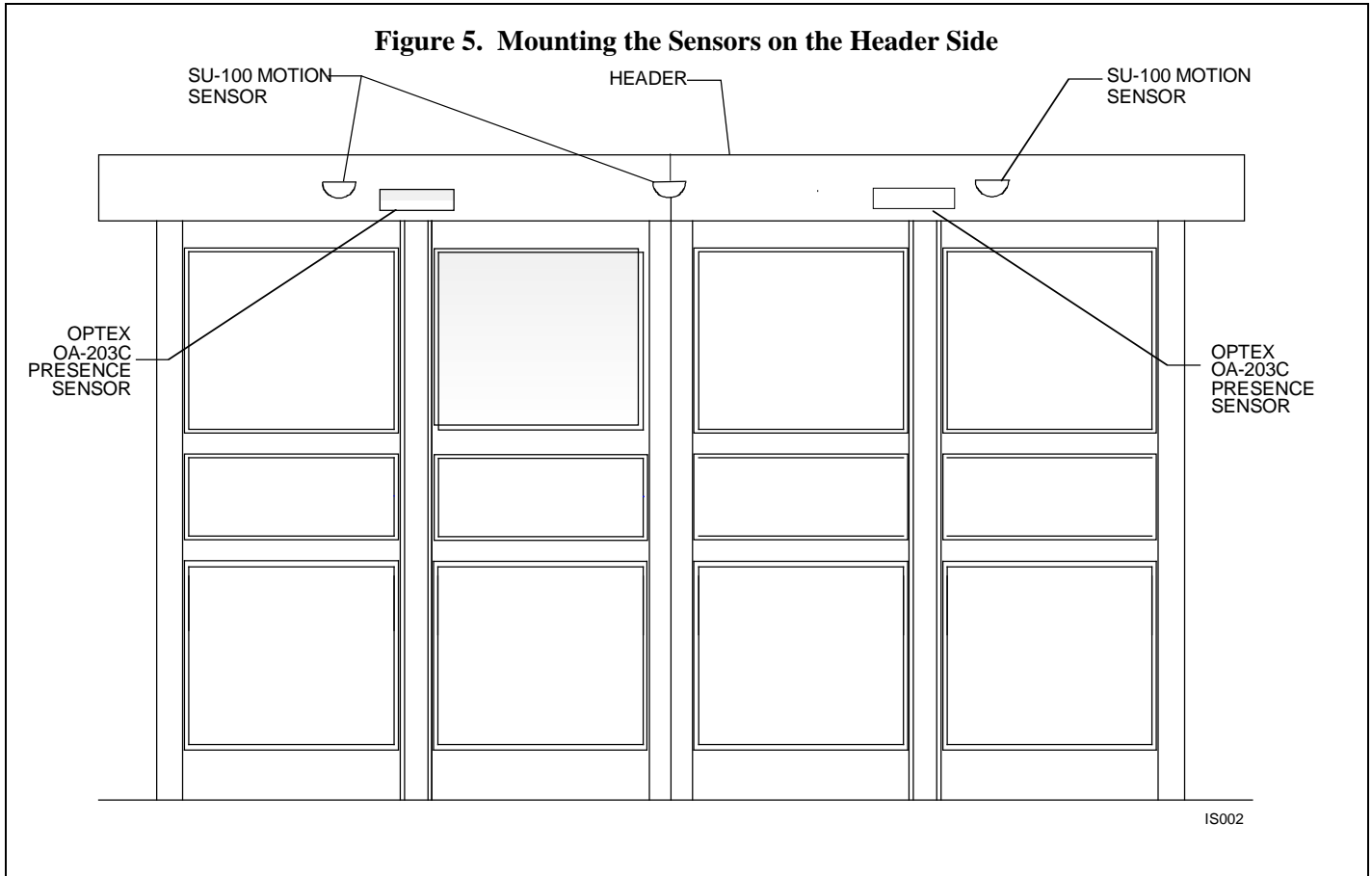

- a. Refer to Stanley Access Technologies document No. 203957, “SU-100 Motion Sensor Installation and Operation,” and **PERFORM** the following:
  - 1) **INSTALL** the narrow-pattern antenna into each SU-100 motion sensor.
  - 2) Using the predrilled holes in the header cover, **MOUNT** two SU-100 motion sensors.
  - 3) **MOUNT** the third SU-100 motion sensor at the center where the header covers meet, and **ENSURE** the sensor is the same height as the other two sensors.

- b. Refer to Optex OA-203C infrared presence sensor manufacturer's installation and operating instructions, and **PERFORM** the following for each OA-203C sensor:
  - 1) **SET** width to maximum.
  - 2) **SET** depth (modes setting switches 7 and 8) to maximum.
  - 3) **SET** presence detection time (modes setting switches 1 and 2) to 60 seconds.
  - 4) **SET** the frequency selection (modes setting switches 3 and 4) such that each sensor is on a different frequency.
  - 5) **SET** the snow mode (modes setting switches 5 and 6) to the setting that best matches the prevailing environment and weather conditions.
  - 6) **SET** the sensitivity to high.
  - 7) Using the predrilled holes in the header cover, **MOUNT** the two Optex OA-203C infrared presence sensors.
- c. **IF** necessary, **INSTALL** header covers.
- d. **OPEN** and **CLOSE** header covers and **ENSURE** they open and close freely without interference.

4.4.2 Refer to Figure 6, and **INSTALL** non-header side sensors onto the steel beam as follows:

**Figure 6. Mounting the Sensors on the Non-Header Side**

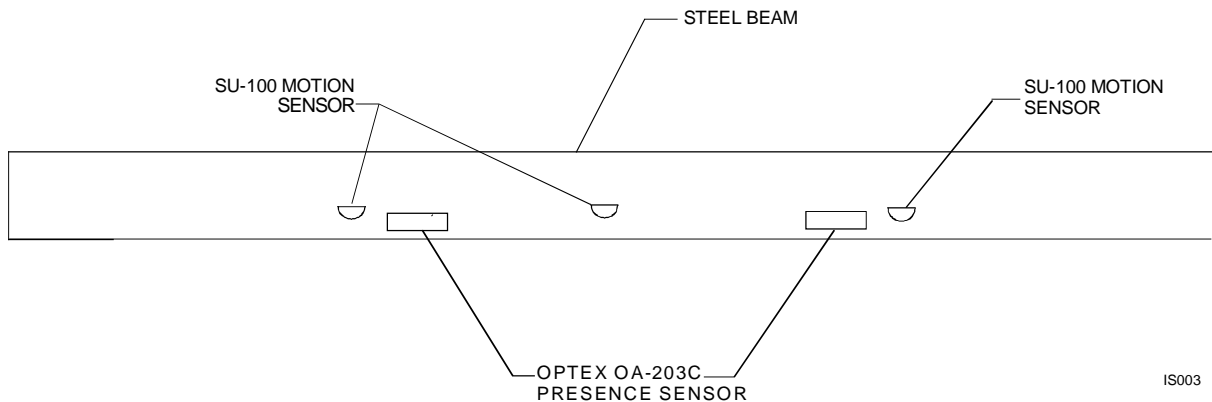

- a. Refer to Stanley Access Technologies document No. 203957, "SU-100 Motion Sensor Installation and Operation," and **PERFORM** the following:
  - 1) **INSTALL** the narrow-pattern antenna into each SU-100 motion sensor.
  - 2) **MOUNT** the three SU-100 motion sensors to the steel beams across from the ones on the header covers.
- b. Refer to Optex OA-203C infrared presence sensor manufacturer's installation and operating instructions, and **PERFORM** the following for each OA-203C sensor:
  - 1) **SET** width to maximum.
  - 2) **SET** depth (modes setting switches 7 and 8) to maximum.
  - 3) **SET** presence detection time (modes setting switches 1 and 2) to 60 seconds.

- 4) SET the frequency selection (modes setting switches 3 and 4) such that each sensor is on a different frequency.
  - 5) SET the snow mode (modes setting switches 5 and 6) to the setting that best matches the prevailing environment and weather conditions.
  - 6) SET the sensitivity to high.
  - 7) MOUNT the two sensors to the steel beam across from the ones on the header cover.
- c. DRILL holes in the steel beam and header to permit routing the wires from the sensor mounting beam to the header.

#### 4.5 Installing the Switch Box

##### NOTE

The switch box contains the toggle switch and power switch. The switch box should be located on an interior wall at a location specified by the Store Manager.

- 4.5.1 MARK the location of the switch box on an interior wall.
- 4.5.2 DRILL four  $1\frac{1}{16}$ " mounting holes into wall.
- 4.5.3 Using the  $\frac{3}{8}$ " masonry anchors, screws, and washers provided, FASTEN the switch box to the wall.
- 4.5.4 REQUEST licensed electrician to PERFORM the following:

##### NOTE

If the harnesses provided are too short, the length of the power harness can be extended in the field with 18 AWG minimum stranded wire. The length of the toggle switch harness can be extended in the field with 24 AWG minimum six-conductor stranded wire. Ensure that *no* wire splices are contained within the conduit. If necessary, splice the harnesses near the harness ends or install extra junction boxes to house the splices.

- a. ROUTE the power harness and toggle switch harness from the header to the switch box.
- b. ROUTE power wire (not supplied) from junction box to header.

##### NOTE

Three ground straps are provided. Two ground straps are in the header and the other is in the switch box.

- c. Using the ground straps provided, GROUND both sides of the header, and the switch box.
- 4.5.5 Set the R1 potentiometer on the timer isolator board to 6 seconds.
  - 4.5.6 Refer to Attachment 3, and CONNECT remaining wiring.

#### 4.6 Installing the Slow Panels

- 4.6.1 Refer to Figure 7, and APPLY a bead of silicone caulk along the entire length of each slow panel glass stop gutter.
- 4.6.2 GLAZE the slow panel.

**Figure 7. Caulking the Glass Stop Gutter**

BEFORE INSTALLING THE GLASS STOP,  
APPLY A BEAD OF SILICONE CAULK IN THIS AREA  
ALONG THE ENTIRE LENGTH OF EACH GLASS  
STOP GUTTER.

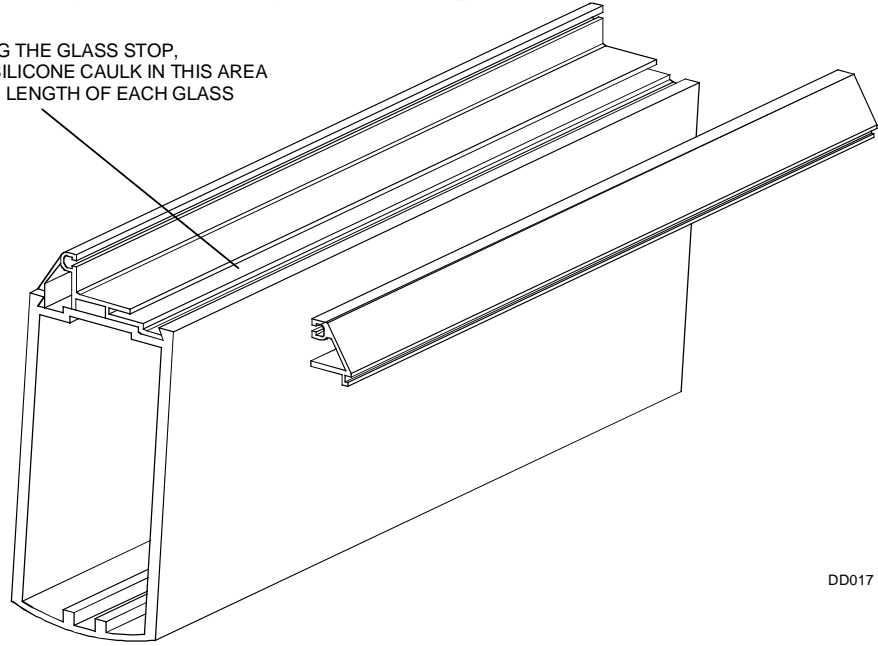

DD017

- 4.6.3 Refer to Figure 8, and LOOSEN the nuts securing the load wheels and anti-riser wheels to the hanger.

**Figure 8. Setting the Load Wheels and Anti-Riser Wheels**

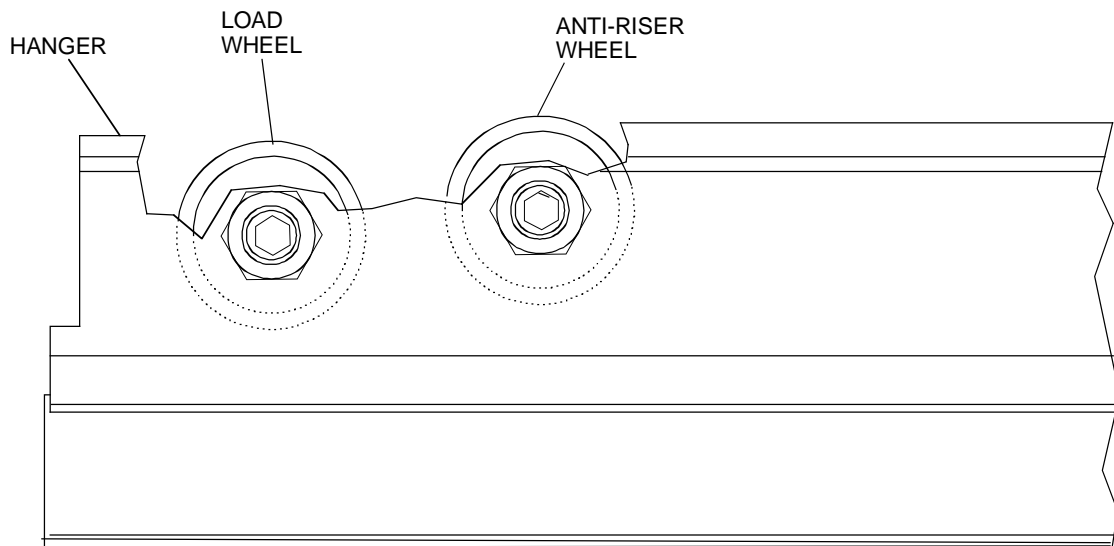

IS004

- 4.6.4 Using an Allen wrench SET the load wheels to the midrange of travel position in the hanger. In this position, the top of the load wheel is  $\frac{1}{16}$ " below the top of the hanger.
- 4.6.5 SET the anti-riser wheels so that the top of each wheel is flush with the top of the hanger.

4.6.6 TIGHTEN the nuts securing the load wheels and anti-riser wheels to the hanger.

### WARNING

Whenever the door anti-riser wheels are not set, there is a possibility that the panel could fall off the hanger track. Use extreme caution when handling the slow panels.

4.6.7 Refer to Figure 9, and HANG the slow panel on the slow panel track as follows:

- LIFT the panel up over the slow panel track, and carefully POSITION the panel onto the track.

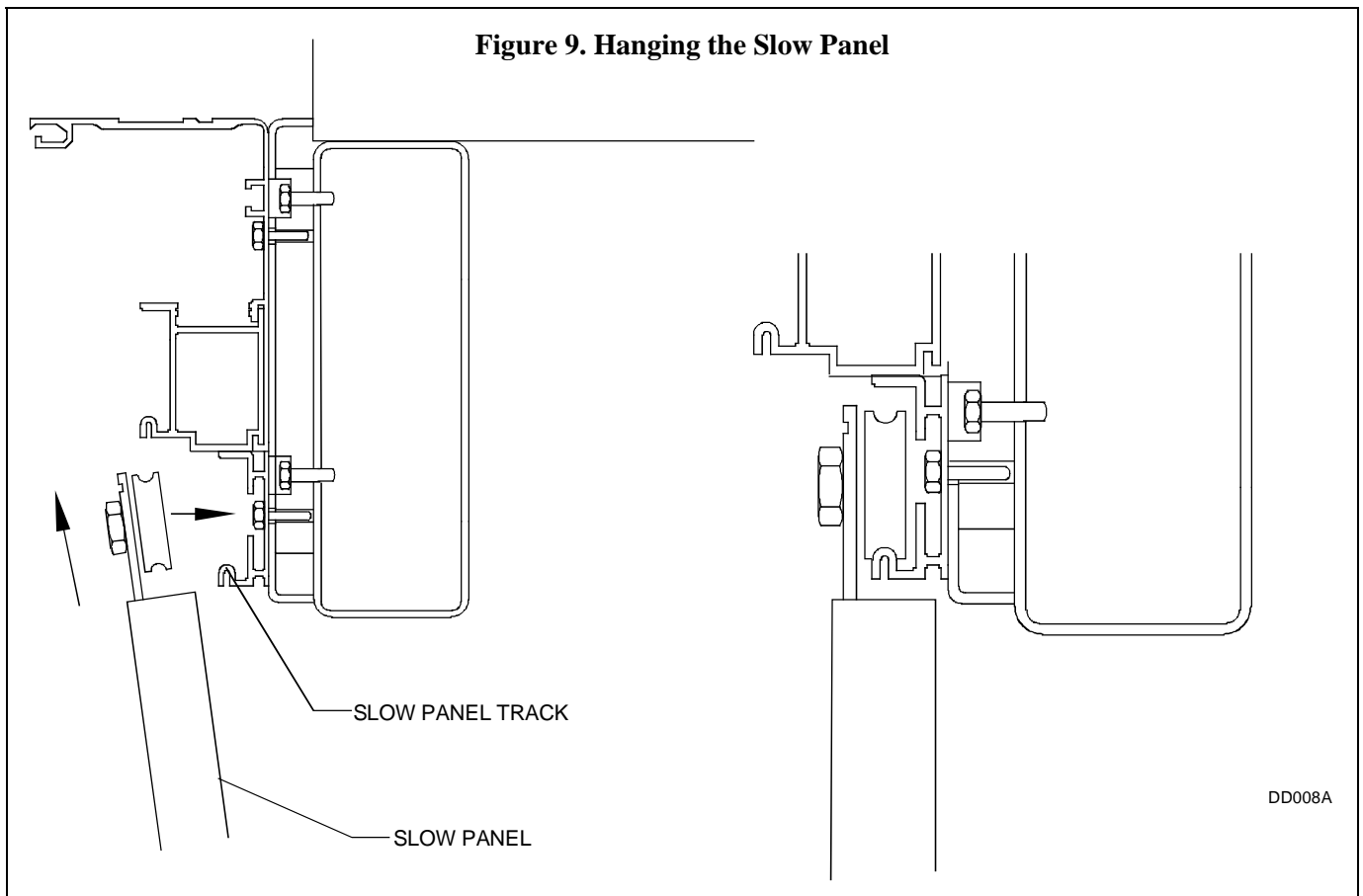

4.6.8 SET the anti-riser wheels so that the top of each wheel lightly contacts the track.

4.6.9 REPEAT Section 4.6 for the opposite slow panel.

#### 4.7 Installing the Fast Panels

4.7.1 ENSURE the glass stop gutter is installed towards the *exterior* of the building.

4.7.2 Refer to Figure 7, and APPLY a bead of silicone caulk along the entire length of each fast panel glass stop gutter.

4.7.3 GLAZE the fast panel.

4.7.4 Refer to Figure 8, and LOOSEN the nuts securing the load wheels and anti-riser wheels to the hanger.

- 4.7.5 Using an Allen wrench, SET the load wheels to the midrange of travel position in the hanger. In this position, the top of each load wheel is  $\frac{1}{16}$ " below the top of the hanger.
- 4.7.6 SET the anti-riser wheels so that the top of each load wheel is flush with the hanger.
- 4.7.7 TIGHTEN the nuts securing the load wheels and anti-riser wheels to the hanger.

**WARNING**

Whenever the door anti-riser wheels are not set, there is a possibility that the panel could fall off the hanger track. Use extreme caution when handling the fast panels.

- 4.7.8 Refer to Figure 10, and HANG the RH fast panel on the header track as follows:
- LIFT the panel up over the header track, and carefully POSITION the panel onto the track.

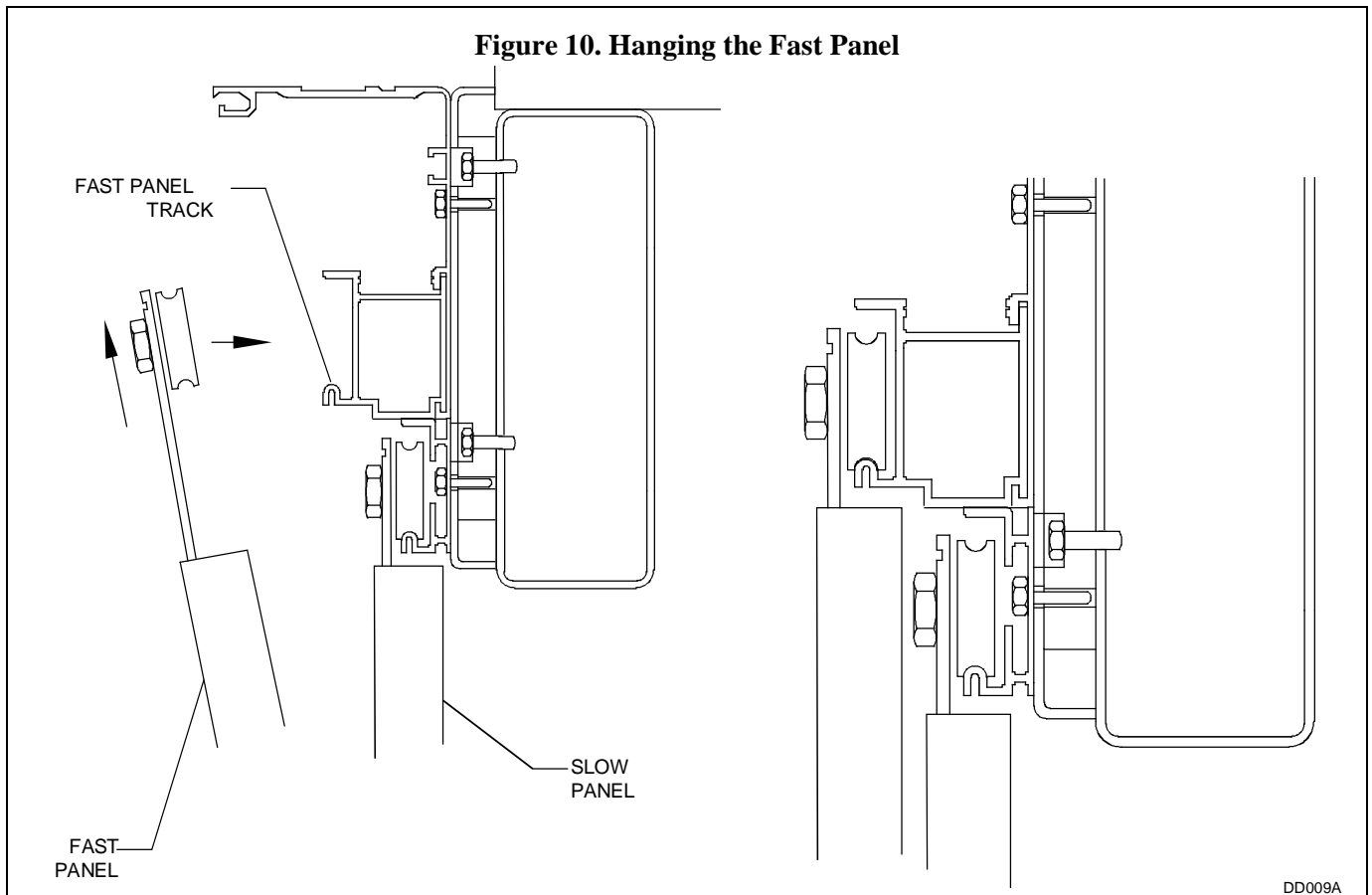

- 4.7.9 SET the anti-riser wheels so that the top of each wheel lightly contacts the track.
- 4.7.10 MOVE the fast panel into the open position, and ENSURE the leading edge of the fast panel is even with or slightly behind the edge of the masonry opening.
- 4.7.11 POSITION the fast panel bumper stop onto the header, and ENSURE the following:
- The bumper stop is on the correct track of the header.
  - The bumper stop contacts the trailing edge of the rear fast panel hanger.
- 4.7.12 REPEAT Section 4.7 for the opposite fast panel.



#### 4.8 Installing the Slow Panel Floor Guide Track

- 4.8.1 POSITION the doors in the fully closed position.
- 4.8.2 MARK a line at the position of the back of the slow panels.
- 4.8.3 MEASURE  $\frac{1}{2}$ " from the line *towards* the masonry opening, and MARK this position.
- 4.8.4 Refer to Figure 11, and ATTACH "L" bracket with tapped holes against wall. (Tapped holes should be towards floor.)

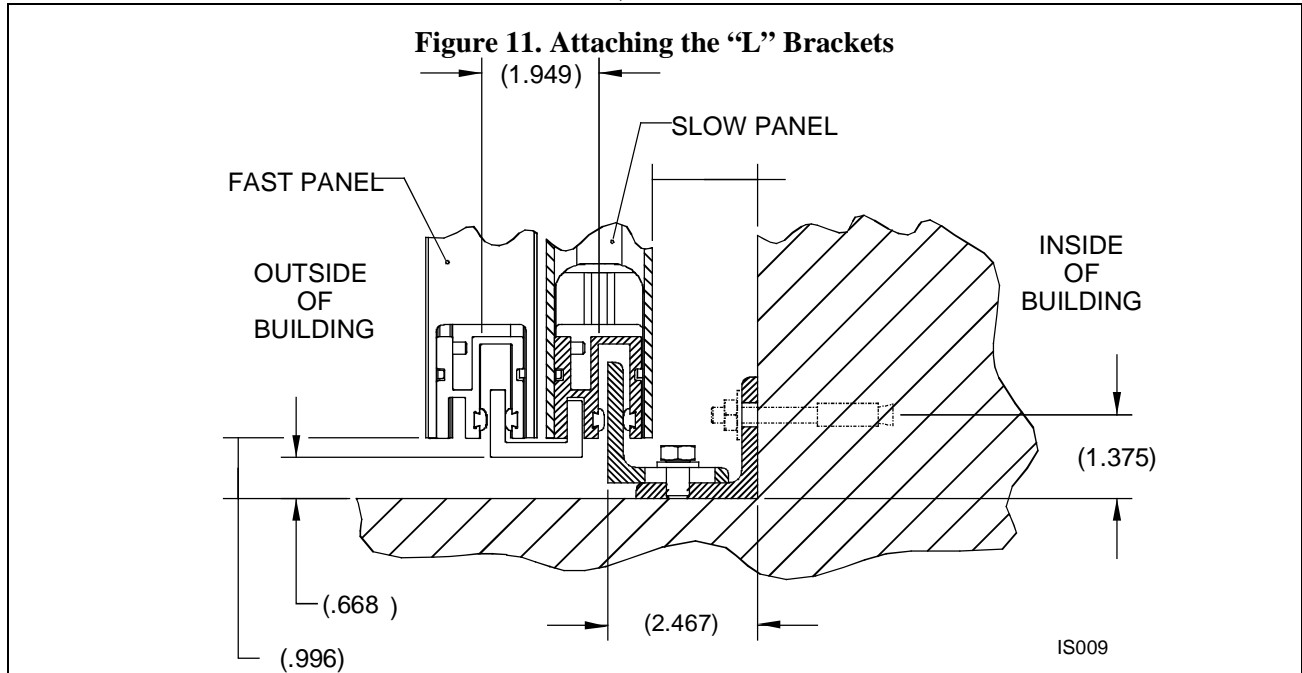

#### NOTE

The "L" brackets can be adjusted so that the panels slide smoothly.

- 4.8.5 ATTACH other "L" brackets with slots on top of other brackets.
- 4.8.6 Refer to Figure 12, and REMOVE the guide wheel shipping bolt.
- 4.8.7 Using  $\frac{1}{4}$ " X  $\frac{3}{4}$ " screws, ATTACH the "C" channels to both slow panels through the clearance holes in the bottom rails, and ENSURE the following:
  - Each "C" channel is installed so that it is under both the fast and slow panels.

**Figure 12. Removing the Guide Wheel Shipping Bolt**

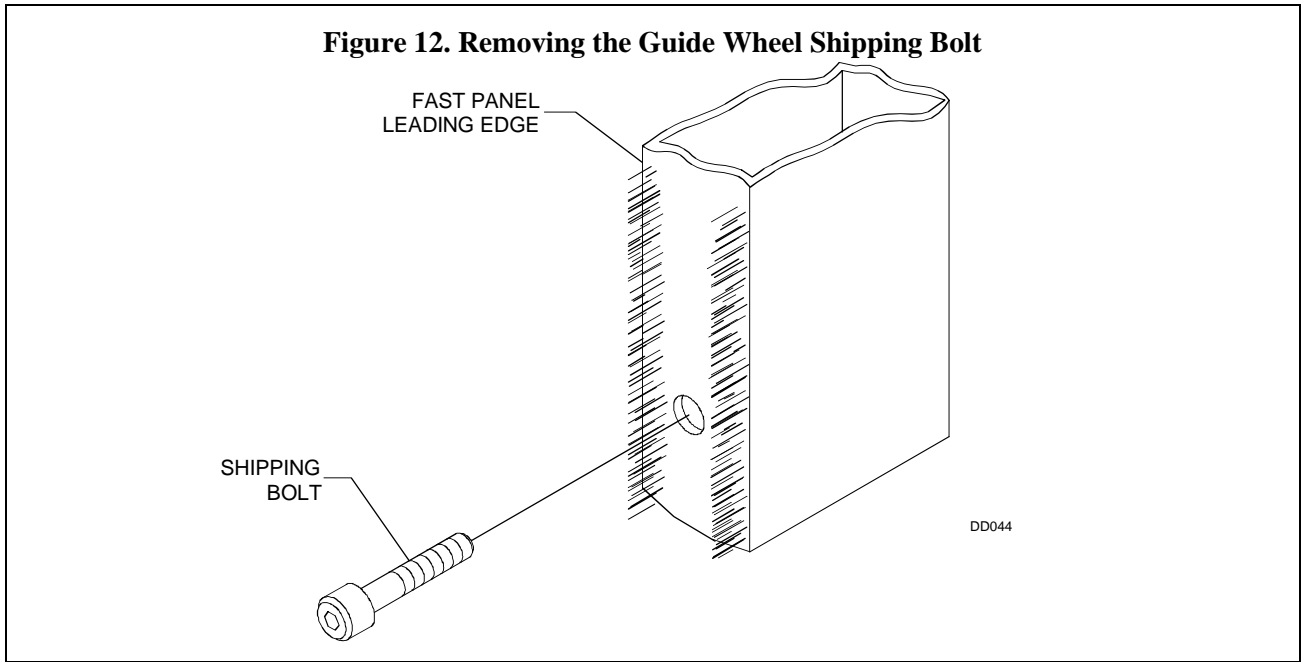

## 4.9 Installing the Reversing Cable

- 4.9.1 Refer to Figure 13, and LOOP the reversing cable over both pulleys on the left side slow panel hangers.

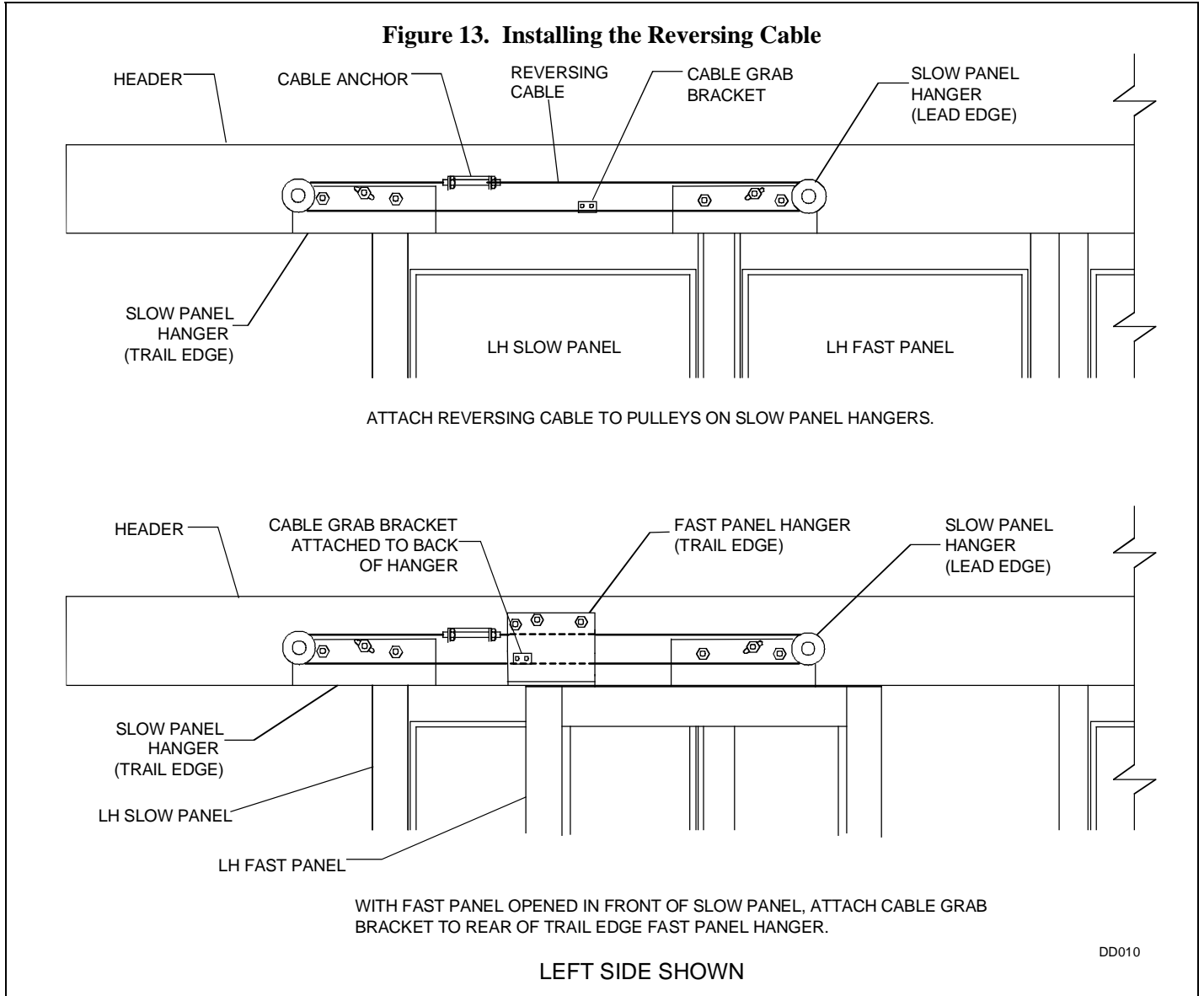

- 4.9.2 ATTACH the reversing cable to the cable anchor mounted on the header bracket, but do not tighten the cable.
- 4.9.3 ATTACH the reversing cable grab bracket to the trail edge hanger of the left fast panel.
- 4.9.4 SET the fast door in the closed position.
- 4.9.5 SET the slow door so that its lead stile is directly in line with the fast door trail stile

4.9.6 SET the cable tension as follows:

- a. Finger **TIGHTEN** the nuts on the inside of the cable anchor.
- b. Using a wrench, **TIGHTEN** the nuts on the inside of the cable anchor an additional one to two turns.
- c. **TIGHTEN** the outer nuts of the cable anchor.

4.9.7 REPEAT Section 4.9 for the right side panels.

#### 4.10 Installing the E-Chain Brackets

4.10.1 Refer to Figure 14, and, using the 10-32 x  $\frac{5}{8}$ " screws provided, **FASTEN** the moving E-chain bracket to the lead edge fast panel hanger.

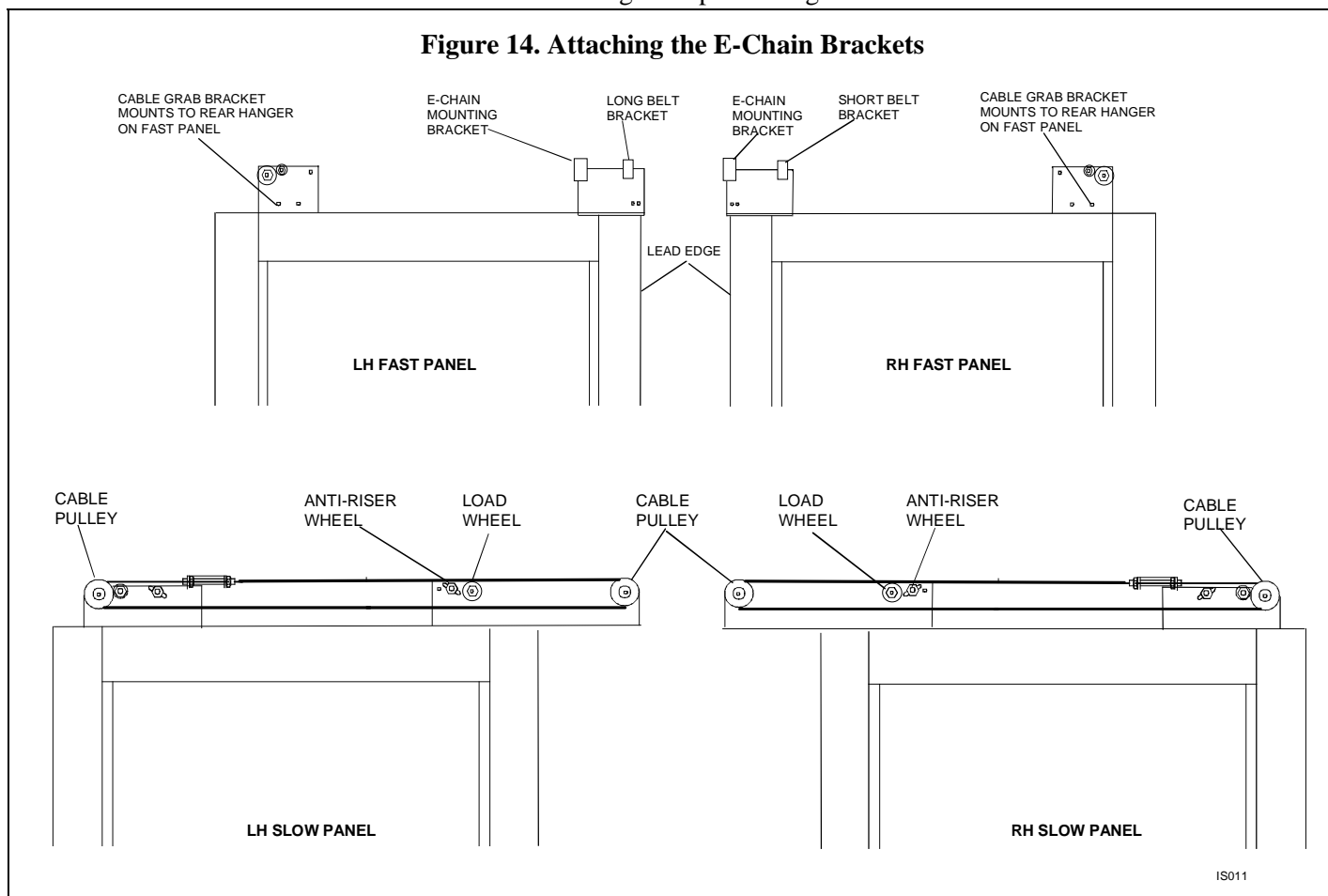

4.10.2 Refer to Attachment 3, and **PERFORM** the following:

- **CONNECT** the doorway holding beam wires to the connector on the moving E-chain bracket.
- **CONNECT** the four-conductor cable from the header to the connector on the stationary E-chain bracket.

4.10.3 REPEAT Section 4.10 for the opposite side.

#### 4.11 Installing and Adjusting the Motor Belt

- 4.11.1 CLOSE doors.
- 4.11.2 CENTER the doors in the opening.
- 4.11.3 INSTALL motor belt over the gear reducer drive pulleys.
- 4.11.4 POSITION the short belt bracket on the RH fast panel lead edge hanger.
- 4.11.5 Using the  $\frac{5}{16}$ "-18 x  $\frac{5}{8}$ " screws provided, FASTEN the short belt bracket to the RH fast panel lead edge hanger.
- 4.11.6 POSITION the long belt bracket on the LH fast panel lead edge hanger.
- 4.11.7 Using the  $\frac{5}{16}$ "-18 x  $\frac{5}{8}$ " screws provided, FASTEN the long belt bracket to the LH fast panel lead hanger.
- 4.11.8 ADJUST motor belt tension.

#### 4.12 Installing the Weatherstripping

- 4.12.1 CLOSE the doors.
- 4.12.2 Refer to Figure 15, and CUT the following to the required length:
  - $3\frac{3}{4}$ " fast panel brush (413344-3)
  - Two  $1\frac{3}{4}$ " slow panel top brushes (413344-2)
  - Two  $1\frac{1}{2}$ " slow panel edge brushes (413344-5)

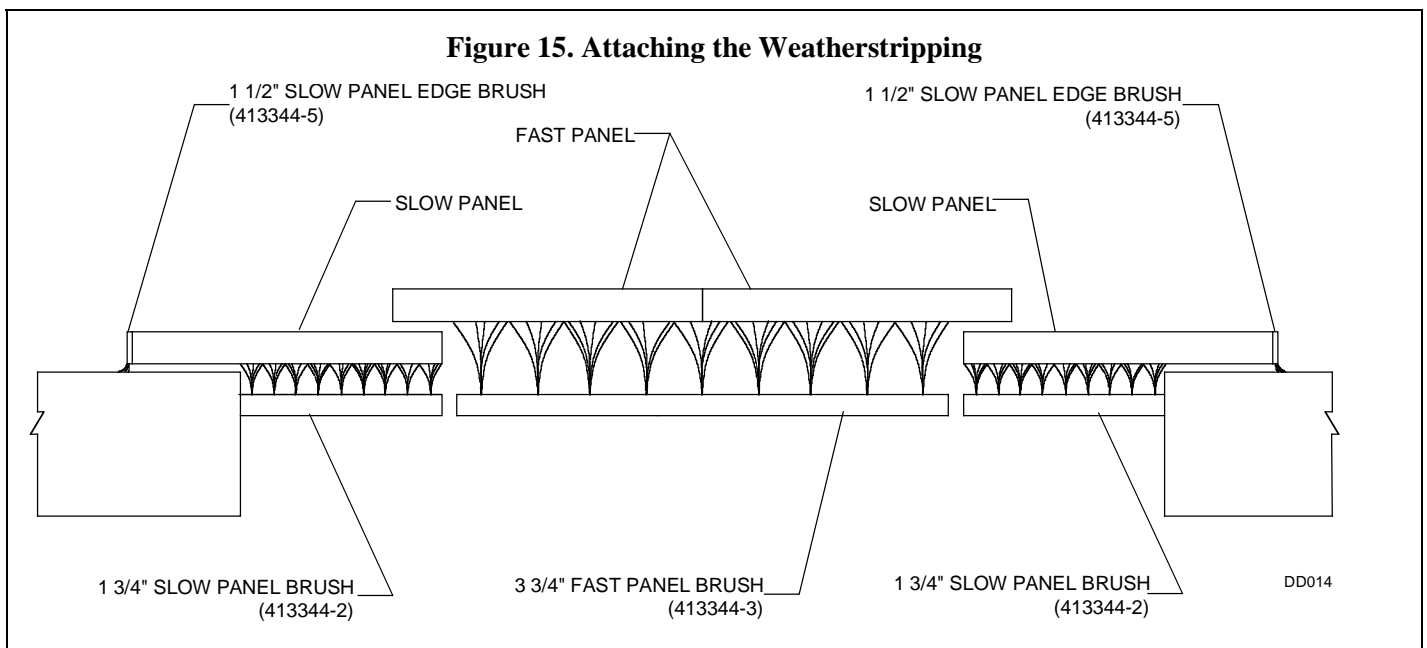

- 4.12.3 INSTALL the  $3\frac{3}{4}$ " fast panel brush (413344-3) onto the underside of the steel beam as follows:
  - a. Using a No. 25 drill and the holes in the  $3\frac{3}{4}$ " fast panel brush as a guide, DRILL fast panel brush mounting holes into underside of steel beam.
  - b. TAP fast panel brush mounting holes for No. 10 screws.

- c. Using No. 10 X  $\frac{1}{2}$ " screws, FASTEN the  $3\frac{3}{4}$ " fast panel brush to the underside of the steel beam.
- 4.12.4 INSTALL the two  $1\frac{3}{4}$ " slow panel top brushes (413344-2) onto the underside of the masonry opening as follows:
- a. Using a No. 25 drill and the holes in the  $1\frac{3}{4}$ " slow panel top brushes as a guide, DRILL slow panel top brush mounting holes into underside of masonry opening.
  - b. TAP slow panel top brush mounting holes for No. 10 screws.
  - c. Using No. 10 X  $\frac{1}{2}$ " screws, FASTEN the two  $1\frac{3}{4}$ " slow panel top brushes to the underside of the masonry opening.
- 4.12.5 Refer to Figure 16, and, using No. 8 self-tapping screws, FASTEN the two  $1\frac{1}{2}$ " slow panel edge brushes (413344-5) to the outboard ends of the slow panels.

**Figure 16. Attaching the Vertical Seals**

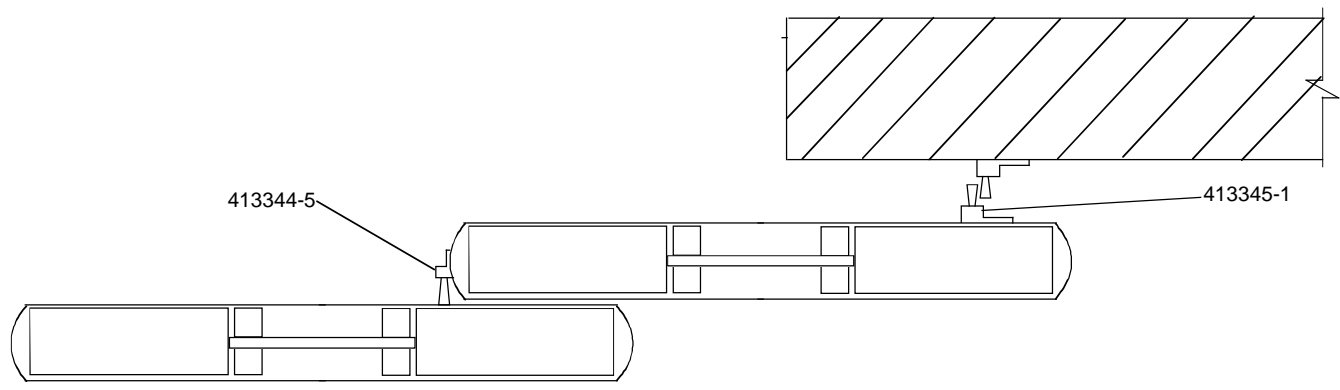

IS007

- 4.12.6 CUT two of the  $3\frac{3}{4}$ " (413344-3) brushes provided to the width of the panels.
- 4.12.7 CLOSE the doors.
- 4.12.8 APPLY brushes to the exterior of the fast doors so that the brushes meet the ground.
- 4.12.9 Avoiding the area of the guide wheel, FASTEN the brushes to the fast panels using the self-drilling, self-tapping screws provided.
- 4.12.10 APPLY the brushes to the interior of the slow panels so that the brushes meet the ground when the doors are closed.
- 4.12.11 FASTEN the brushes to the slow panels using the self-drilling, self-tapping screws provided.
- 4.12.12 OPEN and CLOSE the doors, and VERIFY that the brushes do not prevent the doors from functioning properly.

#### 4.13 **Installing the Doorway Holding Beam Door Position Switch**

##### **NOTE**

The right hand motor includes a door position switch that is pre-installed from the factory.

In the event that the panels are not aligned due to wind or damage, the door position switch shuts off the doorway holding beams before the doors close.

4.13.1 OPEN the doors so that there is a 5" to 6" gap between the two fast panels.

4.13.2 DRILL the belt and INSTALL the switch cam per the instructions in the kit.

#### 4.14 **Tune-In and Adjustment**

4.14.1 Refer to Stanley Access Technologies document No. 204003, "MC521 Controller Installation and Operation," and PERFORM the following:

a. SET Door Type to "Slide Dual Motor."

b. SET Handing to "Right."

c. SET Function Switch to "Switches."

d. SET Door Obstruction Time to "1 sec."

e. Refer to Stanley Access Technologies document No. 204003, "MC521 Controller Installation and Operation," and TUNE-IN door.

4.14.2 Refer to Stanley Access Technologies document No. 203957, "SU-100 Motion Sensor Installation and Operation," and TUNE-IN the SU-100 motion sensors.

4.14.3 Refer to manufacturer's installation and operating instructions, and TUNE-IN the Optex OA-203C infrared presence sensors.

#### 4.15 **Closeout Procedure**

4.15.1 Using the  $\frac{1}{4}$ "-20 x  $\frac{5}{8}$ " screws provided, FASTEN header cover to header.

4.15.2 Refer to Stanley Access Technologies document No. 203743, "Stanley Automatic Sliding Door Safety Decal Installation Guide," (supplied with door package) and PERFORM the following:

- INSTALL the safety decals.
- ENSURE the "CAUTION—STAND BACK" decal is installed on the walls over which the doors slide.

4.15.3 ENSURE glass is not cracked or broken.

4.15.4 ENSURE glass and metal surfaces are clean.

4.15.5 ENSURE door installation area is clean and free of debris.

4.15.6 ENSURE Stanley Service Sticker and all door decals/signage are properly displayed.

#### 4.16 **Replacement Parts**

4.16.1 Refer to Attachment 4 for a listing of the IS 10000 replacement parts.

**Attachment 1**  
**Documents, Definitions, Special Tools, Equipment, Materials, and Consumables**  
(Sheet 1 of 1)

**Documents**

- Stanley Access Technologies document No. 203728, “Dura-Glide™ 2000-, 3000-, and 5000-Series; Dura-Guard™ 2000- and 3000-Series; and Dura-Storm™ 3000-Series Microprocessor Control Box Quick-Reference Guide”
- Stanley Access Technologies document No. 204003, “MC521 Controller Installation and Operation”
- Stanley Access Technologies document No. 203957, “SU-100 Motion Sensor Installation and Operation”
- Manufacturer’s installation and operating instructions for Telco doorway holding beams
- Manufacturer’s installation and operating instructions for Optex OA-203C infrared presence sensor
- Manufacturer’s operating instructions for the handheld remotes

**Definitions**

- None

**Special Tools and Equipment** (including, but not limited to)

- |  |  |
|--|--|
| • Automatic laser level  | • Power manlift  |
| • Caulking gun   | • Pry bar  |
| • Combination square   | • Sawhorses  |
| • Electric drill, metal drill bit set,<br>concrete drill bit set | • Scribe or center punch                               |
| • Level  | • Screwdriver kit                                      |
| • Line level   | • Set of taps for threading “C” channel, if applicable |
| • Open-end wrench set  | • Socket wrench set                                    |
| • Plumb bob  | • SU-100 tune-in remote control                        |
| • Power-head chisel with mortar head                             | • Tape measure   |

**Materials** (including, but not limited to)

- |                            |   |
|----------------------------|---|
| • Assorted fasteners       | • Shims for header and slow track extrusion |
| • Assorted masonry anchors | • 4-conductor, 22-awg cable                 |

**Consumables** (including, but not limited to)

- |                        |                 |
|------------------------|-----------------|
| • Clean rags           | • Glass cleaner |
| • Clear silicone caulk | • Loctite       |
| • Degreaser            | • Tie wraps     |



**Attachment 2**  
**Masonry Opening**  
(Sheet 1 of 1)

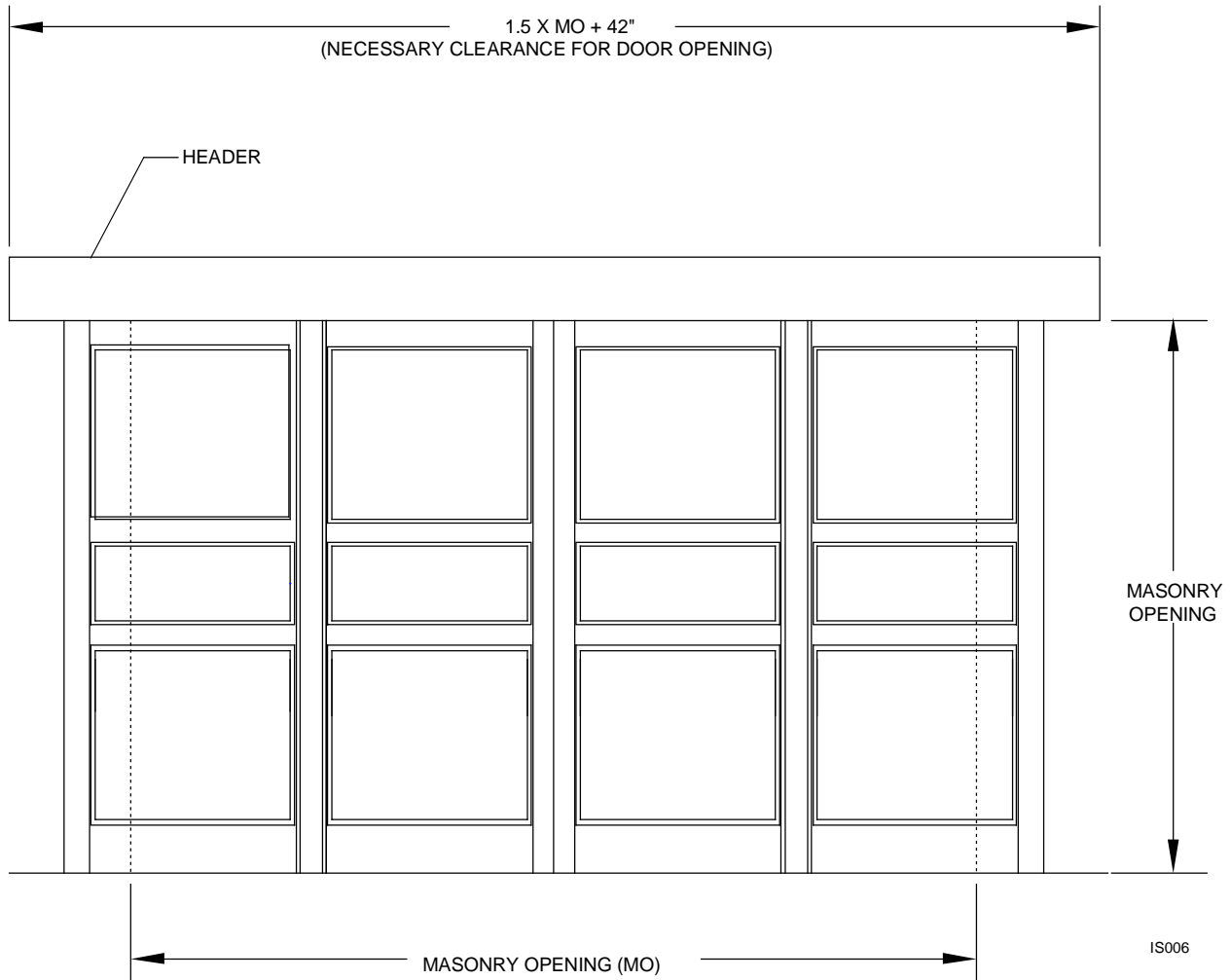

# Attachment 3 System Wiring Diagram (Sheet 1 of 6)

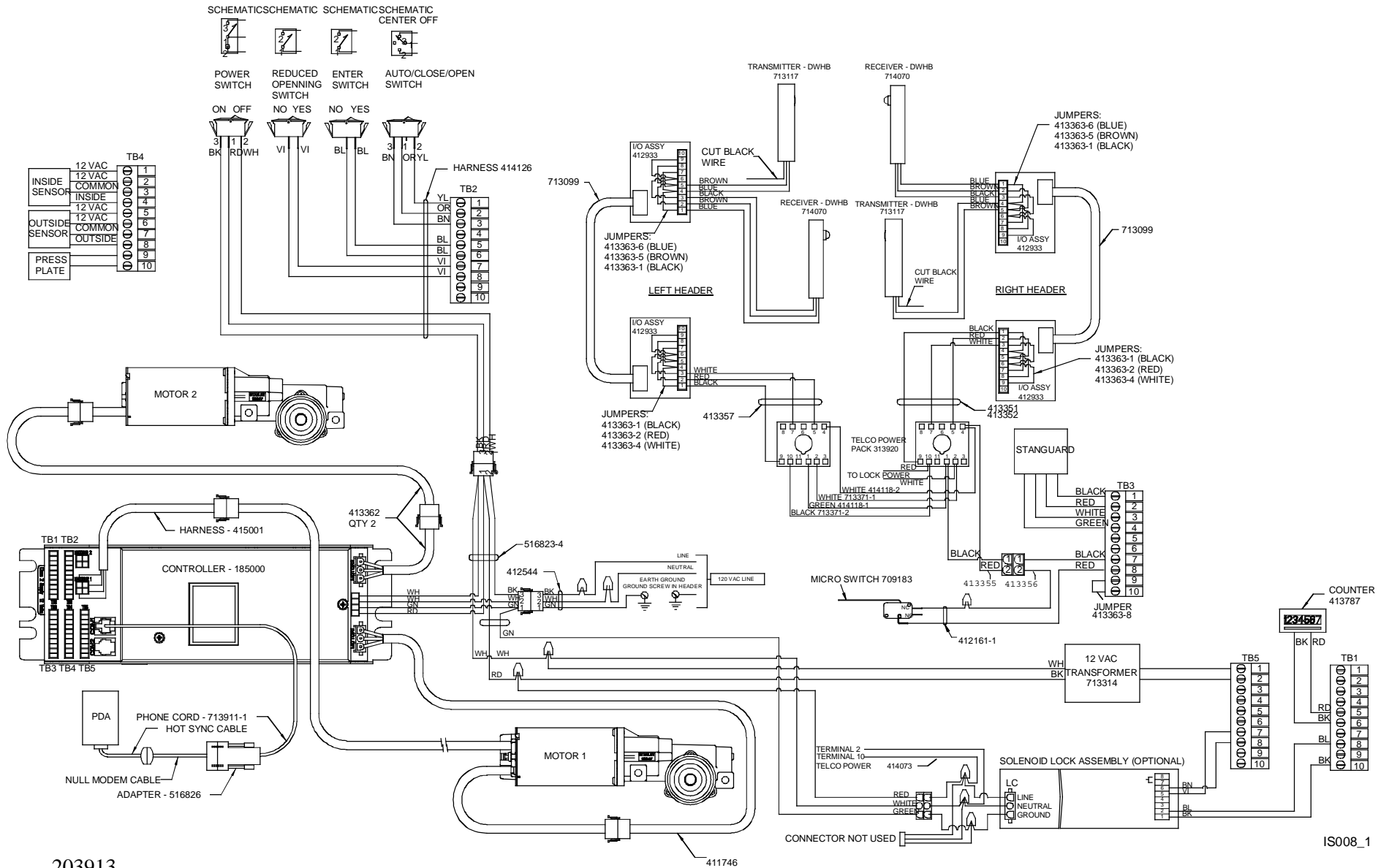

203913

Rev. E, 6/28/05

Page 23 of 30

© 2005, THE STANLEY WORKS. ALL RIGHTS RESERVED.

IS008\_1

**Attachment 3**  
**System Wiring Diagram**  
 (Sheet 2 of 6)

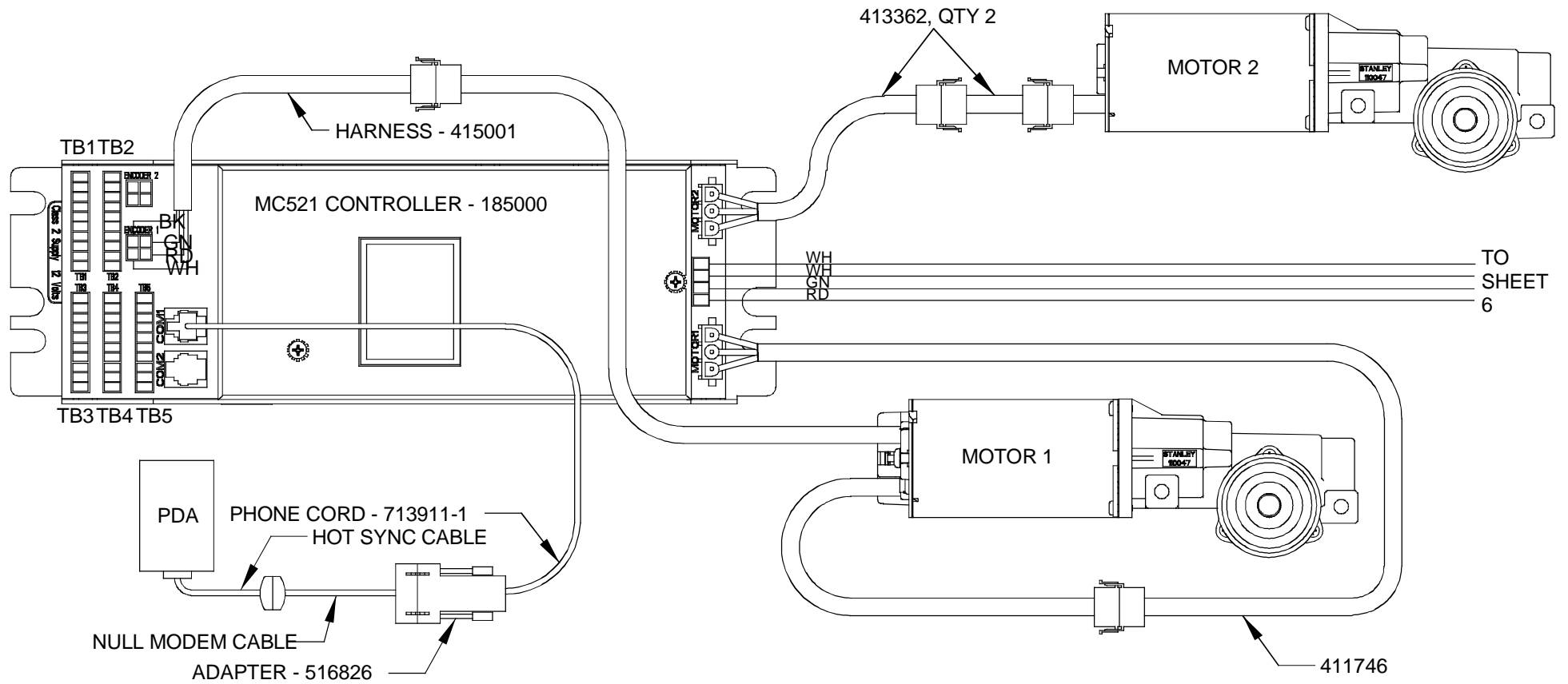

IS008\_2

**Attachment 3**  
**System Wiring Diagram**  
 (Sheet 3 of 6)

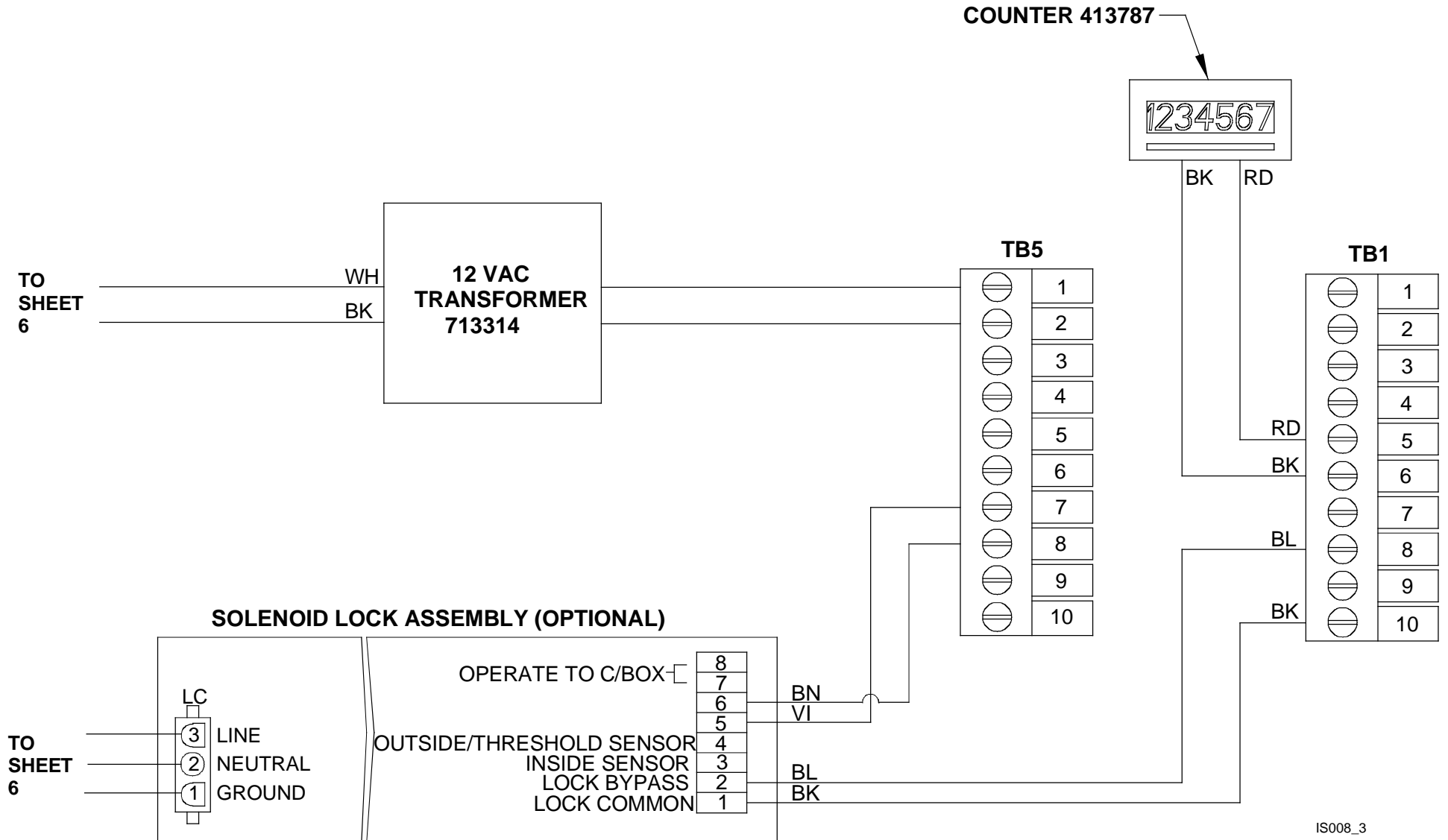

IS008\_3

# Attachment 3

## System Wiring Diagram

(Sheet 4 of 6)

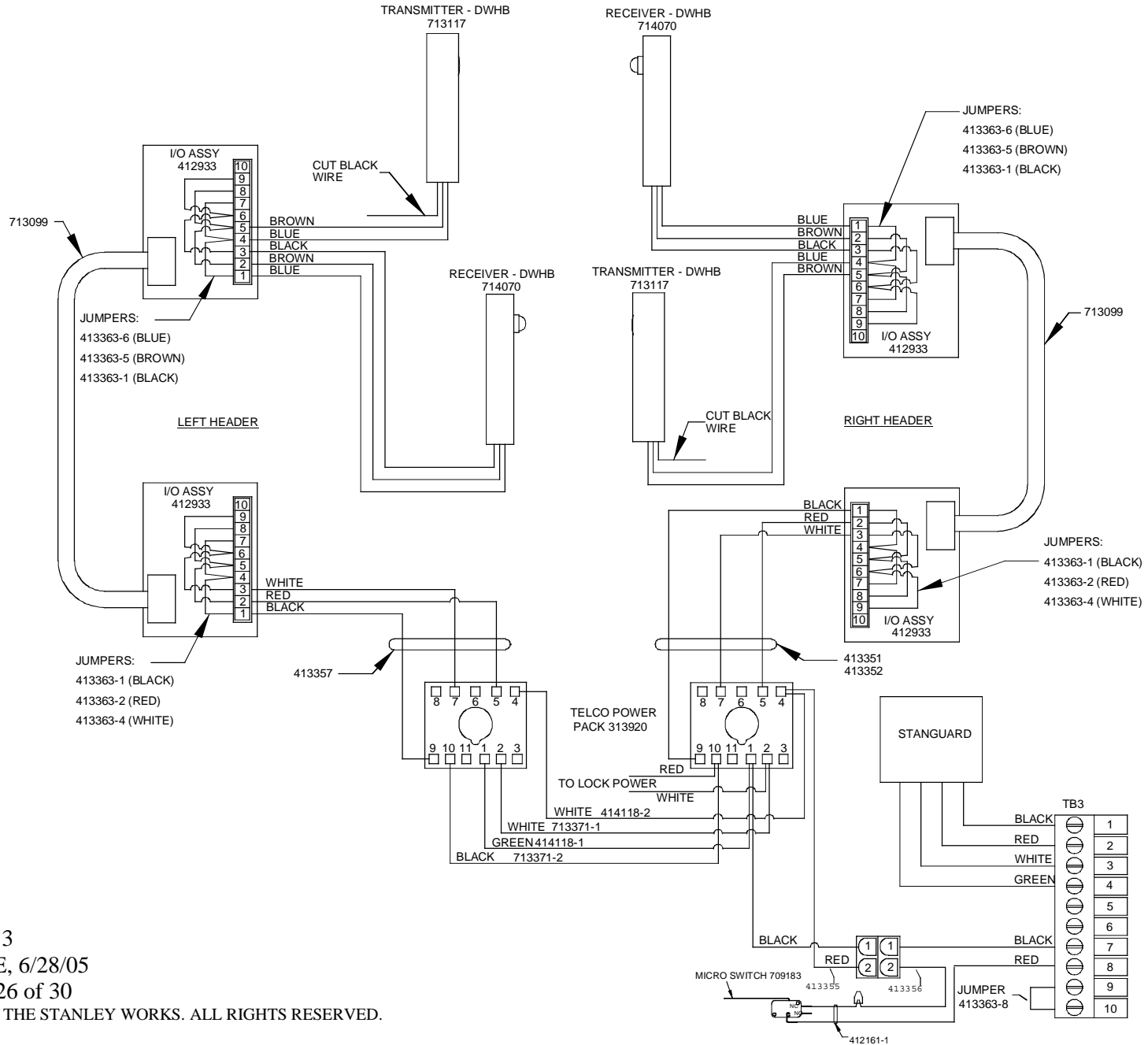

# Attachment 3 System Wiring Diagram (Sheet 5 of 6)

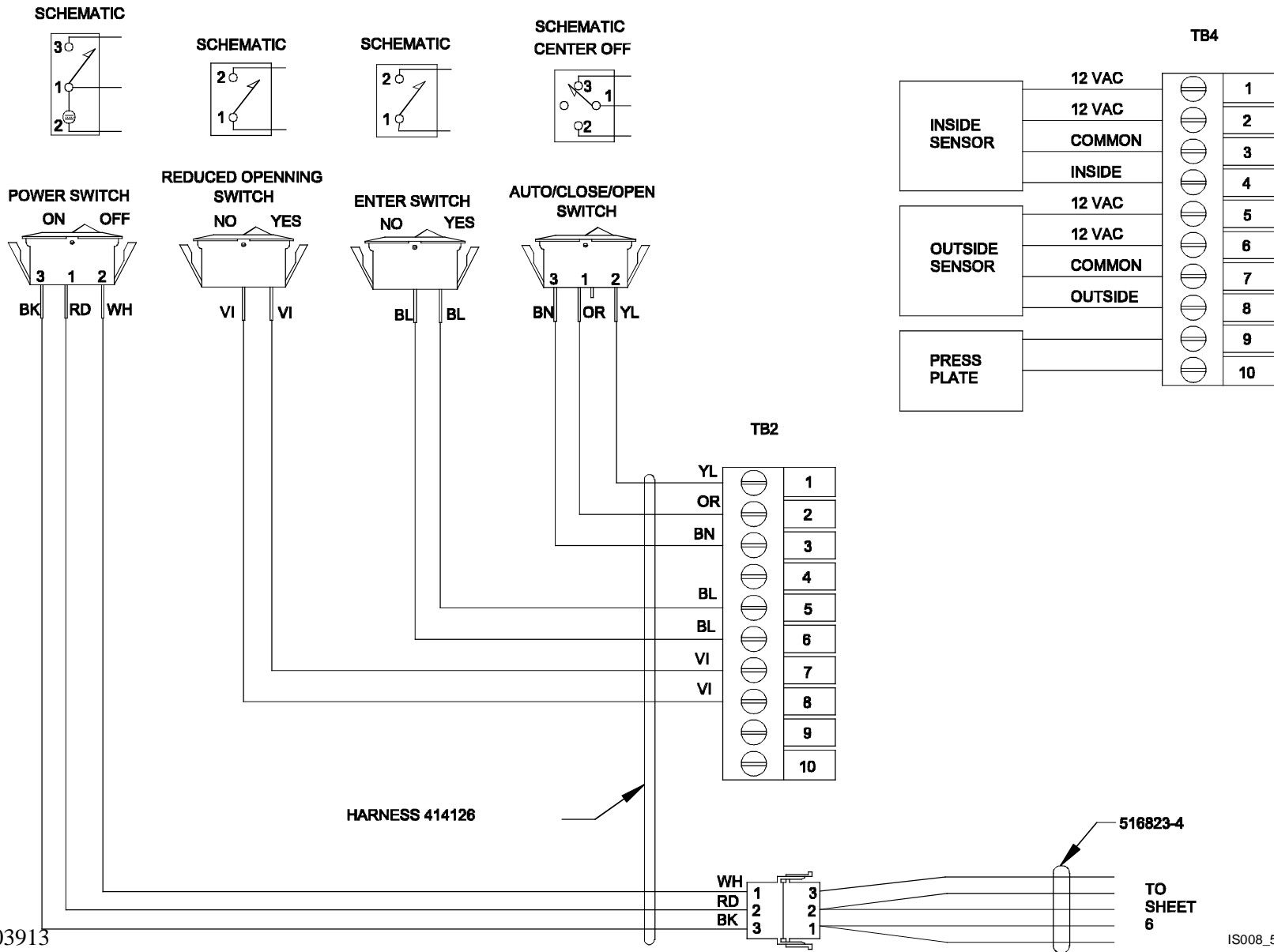

203913

Rev. E, 6/28/05

Page 27 of 30

© 2005, THE STANLEY WORKS. ALL RIGHTS RESERVED.

ISO08\_5

**Attachment 3**  
**System Wiring Diagram**  
 (Sheet 6 of 6)

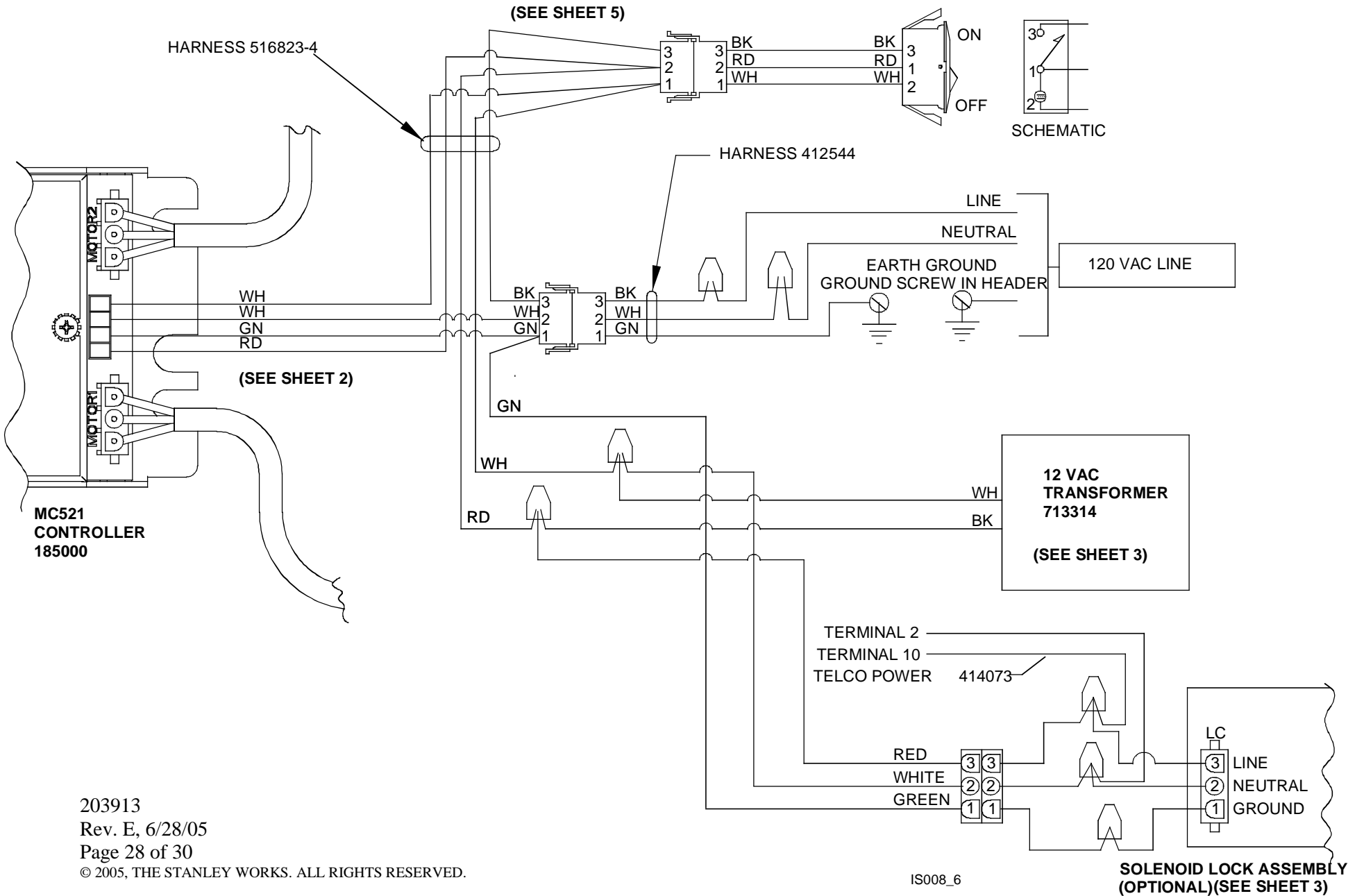

**Attachment 4**  
**Replacement Parts**  
(Sheet 1 of 2)

<b>Part No.</b>	<b>Qty.</b>	<b>Description</b>		
111497	1	Header Assy.		
111508-1	2	Plate, Header Mounting		
185014-1	1	Panel, Fast -LH		
185014-2	1	Panel, Fast -RH		
185015-1	1	Panel, Slow -LH		
185015-2	1	Panel, Slow -RH		
313970	1	Hardware Kit Containing		
		<b>Qty</b>	<b>Part No.</b>	<b>Description</b>
		6	516669	Sensor, Microwave Motion
		4	516721	OPX OA-203C Motion Presence Sensor
		1	934312965	Stanguard Sensor Pkg
		1	111522	Bracket—Stanguard—IS10000
		1	111715	Switch Box Assy-IS10000
		1	313727	Kit-Decal IS10000
		60	711491	Wire-Cable-6 Conductor-18 AWG
		2	313651	Cable Kit IS10000
		1	204003	Inst Instr MC521 Controller
		1	203913	Inst Manual-IS10000
		1	205529	Packaging-Carton-25.5X13.75X10
313971	1	Hardware Kit Containing		
		<b>Qty</b>	<b>Part No.</b>	<b>Description</b>
		1	516394	Hangar Package, Lowes
		6	351245499	Screw, HHM-5/16-18 X 5/8
		1	413992	Bracket-Center Cover-IS10000
		1	413343	Bracket Extension-IS10000
		12	713362-1	Screw, FHM-PH ¼-20 X 3/4
		2	516844	Channel Machining
		2	516843	Angle Support
		2	516847	Angle Support
		1	516413	Kit-Installation-Lowes
		1	516397	Endcap Package-IS10000
		1	205529	Packaging-Carton-25.5X13.75X10

203913

Rev. E, 6/28/05

Page 29 of 30

© 2005, THE STANLEY WORKS. ALL RIGHTS RESERVED.



**Attachment 4**  
**Replacement Parts**

(Sheet 2 of 2)

516394	1	Hanger Package Containing:		
		<b>Qty.</b>	<b>Part No.</b>	<b>Description</b>
		16	413341	Shim, Hanger
		8	413600	Spacer, Hanger
		4	111509	Hanger-Fast
		24	350696499	Screw, Cap, FHL-HEX $\frac{5}{16}$ -18 x 2 $\frac{1}{2}$ "
		1	111863-LRH	Hanger, LH Rear-Slow
		1	111863-LHL	Hanger, LH Lead-Slow
		1	111863-RHR	Hanger, RLH Rear-Slow
		1	111863-RHL	Hanger, RH Lead-Slow
		8	412406	Roller Assy, Anti Riser
		8	711627	Plate, Back up
		8	411499	Wheel Assy, Load
		16	380257499	Nut, Hex-Jam $\frac{3}{4}$ -10
		10	52010200	Clamp, Cable .375 ID
		6	351245499	Screw Hex HD $\frac{5}{16}$ 18 x 5
	516396	1	Weatherstripping Kit Containing:	
		<b>Qty.</b>	<b>Part No.</b>	<b>Description</b>
		2	413344-1	Seal, Vertical- Slow Panel
		3	413344-2	Seal, Horizontal-Slow Panel
		4	413344-3	Seal, Horizontal-Fast Panel
		4	413345-1	Seal, Horizontal-Wall