

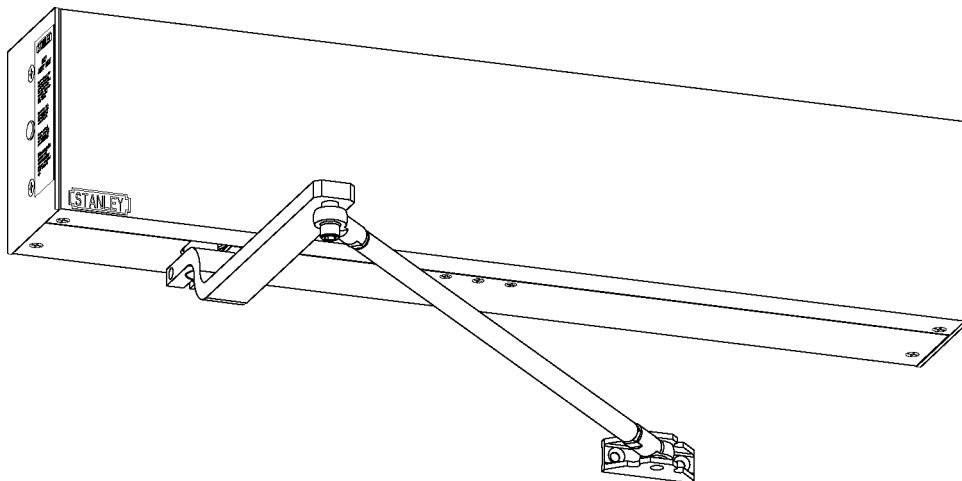

MA900

Installation and Owners Manual

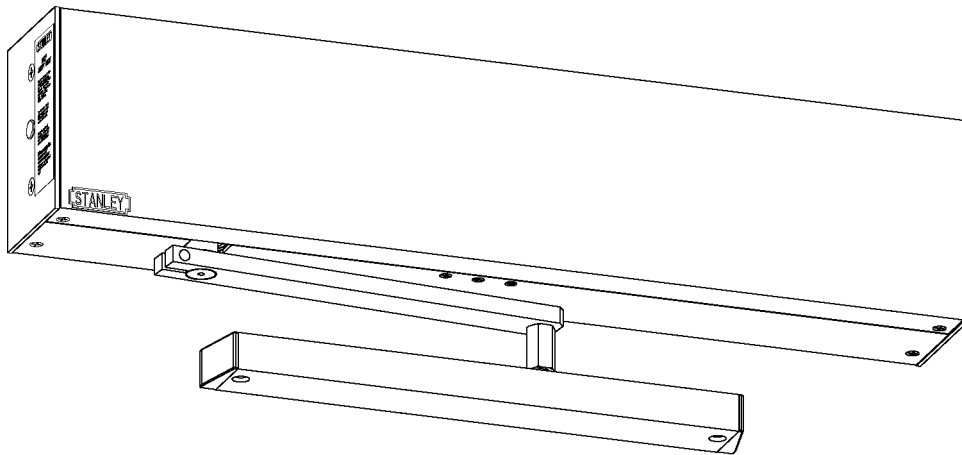

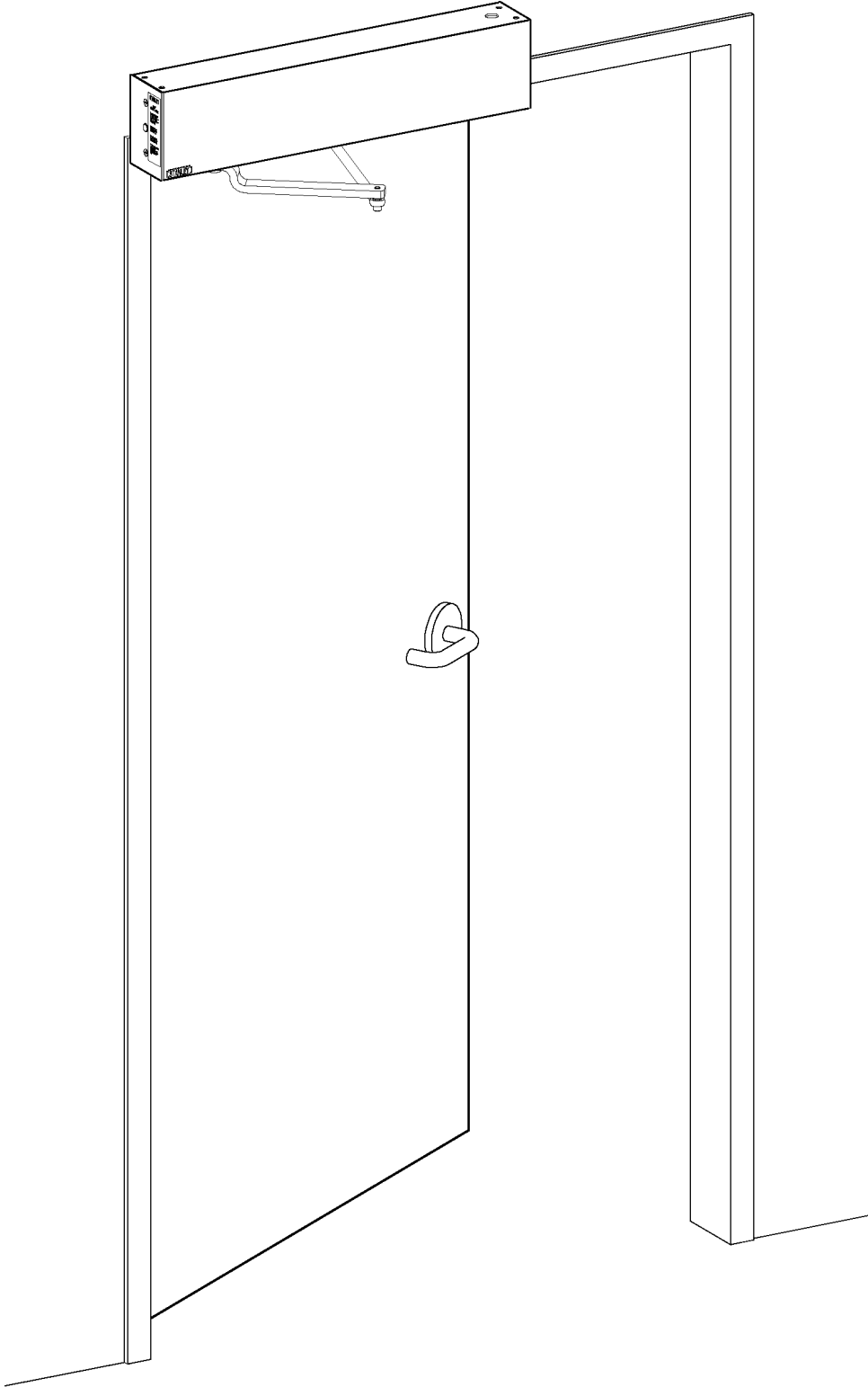

© 1998, The STANLEY WORKS. ALL RIGHTS RESERVED.

Table of Contents

Safety Requirements	4
Introduction	5
Definitions of Terms	6
Stanley MA900 Features and Functions	6
Minimum Installation Requirements	7
Items Supplied	8
Tools Required	9
Installation Procedures	10
Header Assembly Installation	10
Connect Actuation Devices	15
Power Requirements	15
Wiring Diagrams	16
Tune-In Procedures	18
Optional Sequencing Timers	22
Safety Checks	23
Safety Decals	23
Troubleshooting	25

Warranty

The MA900 Series is warranted against defects in material and workmanship for a period of one year from date of installation.

Safety Requirements

Please read this section carefully. It contains important information concerning the operating features of your Stanley MA900 Door Operator, as well as safety precautions to be taken before, during and after installation.



This caution symbol appears throughout the manual. It identifies important safety instructions. Read these instructions carefully. Failure to follow these instructions may result in serious or fatal personal injury or property damage.



Information symbol identifies notes that provide important information about the installation and operation of the MA900.



Do not wear rings, watches or loose clothing while installing or servicing the door operator.



Daily safety checks must be made to assure proper door operation. See Safety Checks section of this manual or the decal on the side of the operator header.



ANSI Standard A156.19 requires that specific labels be applied to the door. See Safety Decals section of this manual for information on applying these labels.



To avoid the risk of electrical shock, connect the power wire to only a properly grounded outlet.



Never let children operate or play near the door. Keep RF transmitters in a location inaccessible to children. Misuse of a door-actuation device may result in serious injury.



Operate the door only when it is fully visible and clear of any obstruction. Keep the door in sight until it is completely closed. **KEEP CHILDREN AND PETS AWAY FROM THE DOOR WHILE IT IS MOVING.**



If damage to any mechanical drive or structural component of the unit is observed, discontinue use and contact an authorized Stanley dealer or the Stanley Customer Service Department.



If permanent wiring is required by local code, disconnect power at the fuse box or circuit breaker box before attempting wiring connections.



Check local building and electrical codes for mandatory installation and wiring requirements.



Read carefully the assembly and mounting sections of this manual. They provide information about the tools, and in some cases the additional hardware, required to insure a safe and speedy installation.

Introduction

This Installation manual provides you with the information you need to install the Stanley MA900 Door Operator. The Stanley MA900 Installation Kit contains hardware, components and materials required for a typical installation. Make sure the operator you have selected meets your application requirements. The Stanley MA900 is available in four configurations (see Figs. 1-4):

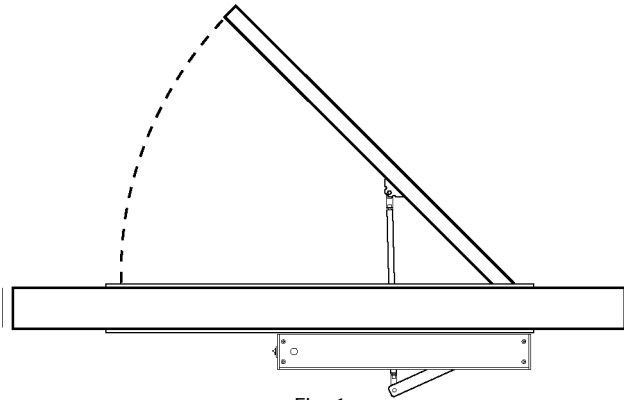

Fig. 1
Right-hand outswing door.
(for RH and LHR door opening)
EDP Number 09 1000

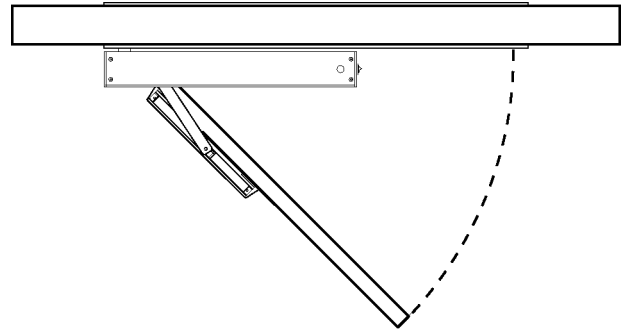

Fig. 2
Right-hand inswing door.
(for RH and LHR door opening)
EDP Number 09 1010

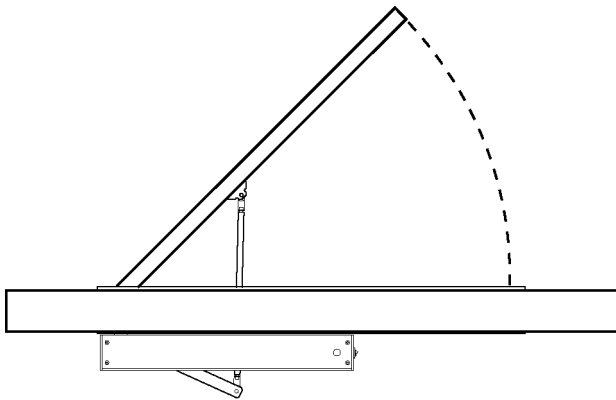

Fig. 3
Left-hand outswing door.
(for LH and RHR door opening)
EDP Number 09 1020

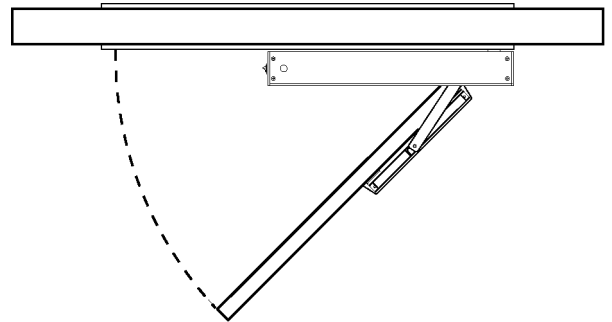

Fig. 4
Left-hand inswing door.
(for LH and RHR door opening)
EDP Number 09 1030



The electrical connection of the Stanley MA900 to the building wiring must be done by a qualified USEA electrician.

Definitions of Terms

door jamb – Either of the two vertical sides of a doorway.

electric strike – Electronically controlled latching/unlatching device.

fail safe lock – An electric lock that automatically unlocks with any power interruption.

fail secure lock – An electric lock that requires power to unlock.

header – The enclosure that contains the operator.

operator – The mechanism that drives the door.

push plate – A wall-mounted actuator switch. When the plate is pushed, a signal is sent to the operator.

reveal – The distance from the mounting surface of the operator to the face of the door.

stack pressure – A force on the door, created by an internal air handling system or external environmental conditions.

strike plate – The metal plate on the door jamb that holds the bolt of the lock when the door is closed.

Stanley MA900 Features and Functions

Magic-Touch™ A feature that allows the door to be actuated by a slight movement of the door.

Manual Operation If power is shut off, the door functions as a manual door.

Lock Delay Delays the operation of the door 1/2 sec to allow a lock to release.

Power Close In a building in which stack pressure exerts a force that prevents the door from closing, the Power Close feature can be actuated to help it to close.

Swing-Safe Technology The electronic safety control senses an obstruction during the opening cycle of the door. The operator immediately reverses the door direction, allowing time for the obstruction or person to clear the swing path area of the door.

Adjustable Time Delay When it reaches the fully open position, the door pauses for a specified time before closing. The time delay is adjustable, and must be set in the range of 5 to 30 sec.

Adjustable Opening Angle The angle of the door at the fully open position can be set in the range of 90° to 120°.

On/Off Switch When the switch is in the On position, power is supplied to the operator. When the switch is in the Off position, the MA900 works as a manual closer.

Mode Switch Controls Hold Open or Operating Mode (Day or Night).

- **Hold Open** - When activated the door is moved and held in the fully open position.

- **Day and Night Operating Modes** - In Day mode all features are fully operational. In Night mode actuators (for example, a push plate or an RF transmitter) are deactivated. If the Magic-Touch™ feature has been turned on, it remains active.

Sequential Operation This feature provides for sequenced operation of two units. For example, in a vestibule the opening of the sec unit can be delayed 1 to 30 sec after the opening of the first.

Easy Interface The MA900 can be easily interfaced with various access control system components, including keypads, card access, proximity, electric strikes and exit devices with electric latch retraction.

Minimum Installation Requirements



To be suitable for the installation of a Stanley MA900, the door and frame must meet the following minimum requirements:



Check with the building manager or other responsible individual to make sure that you are working on the correct door.

1. The MA900 must be mounted on the interior side of the building.
2. The door can weigh no more than 250 lb.
3. The door can be no more than 44 in. wide.
4. If there is a manual closer, it must be removed or made inoperable.
5. The door must be in good working order. The hinges must work properly; the door must swing freely through its entire range.
6. The frame must be made of 16 gauge welded steel or better; or the mounting surface must be masonry; or additional support must be provided behind the operator (see Figs 5 and 6).
7. For an outswing door, the reveal must be in the range 0-6 in. For an inswing door the reveal must be 0 in.
8. Power for the MA900 should be installed before starting the installation of the operator.
See Electrical Specifications section of this manual.

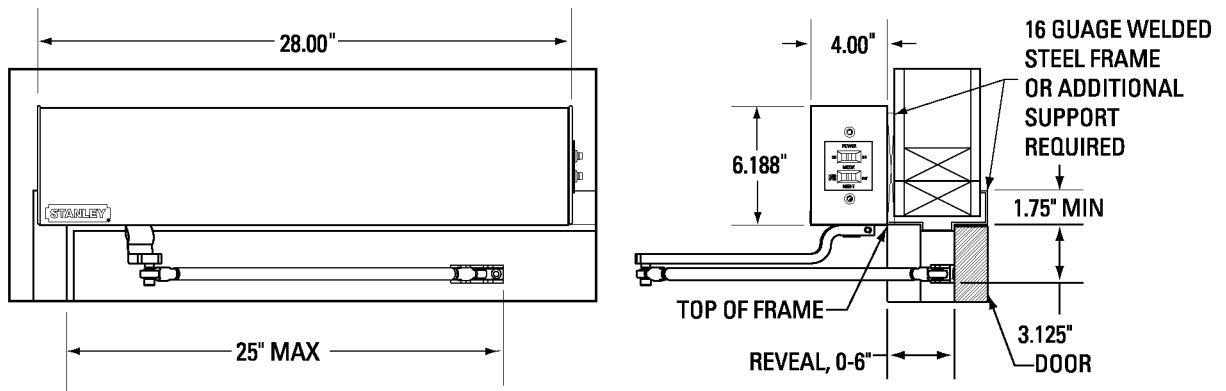

Fig. 5
Typical left hand outswing application

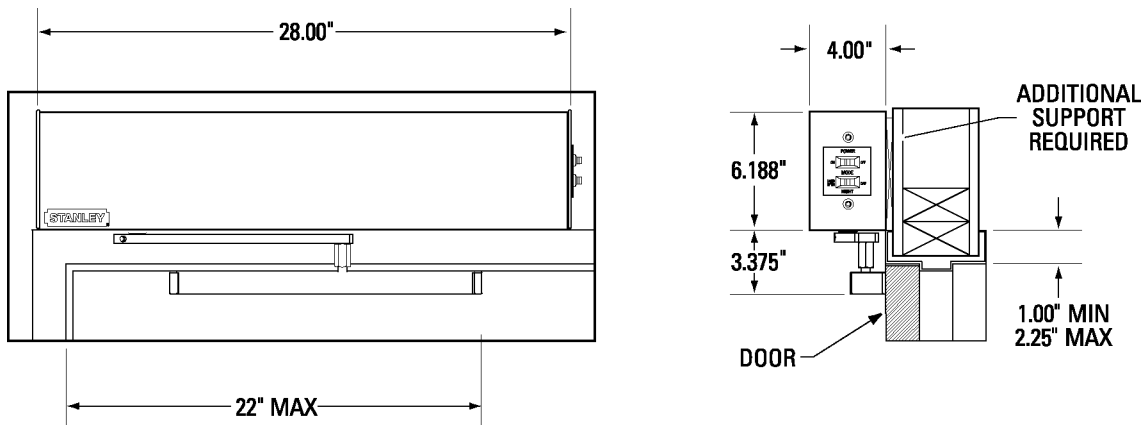

Fig. 6
Typical right hand inswing application

Items Supplied

Operator Components

The Stanley MA900 operator kit contains the following items (see Fig. 7).

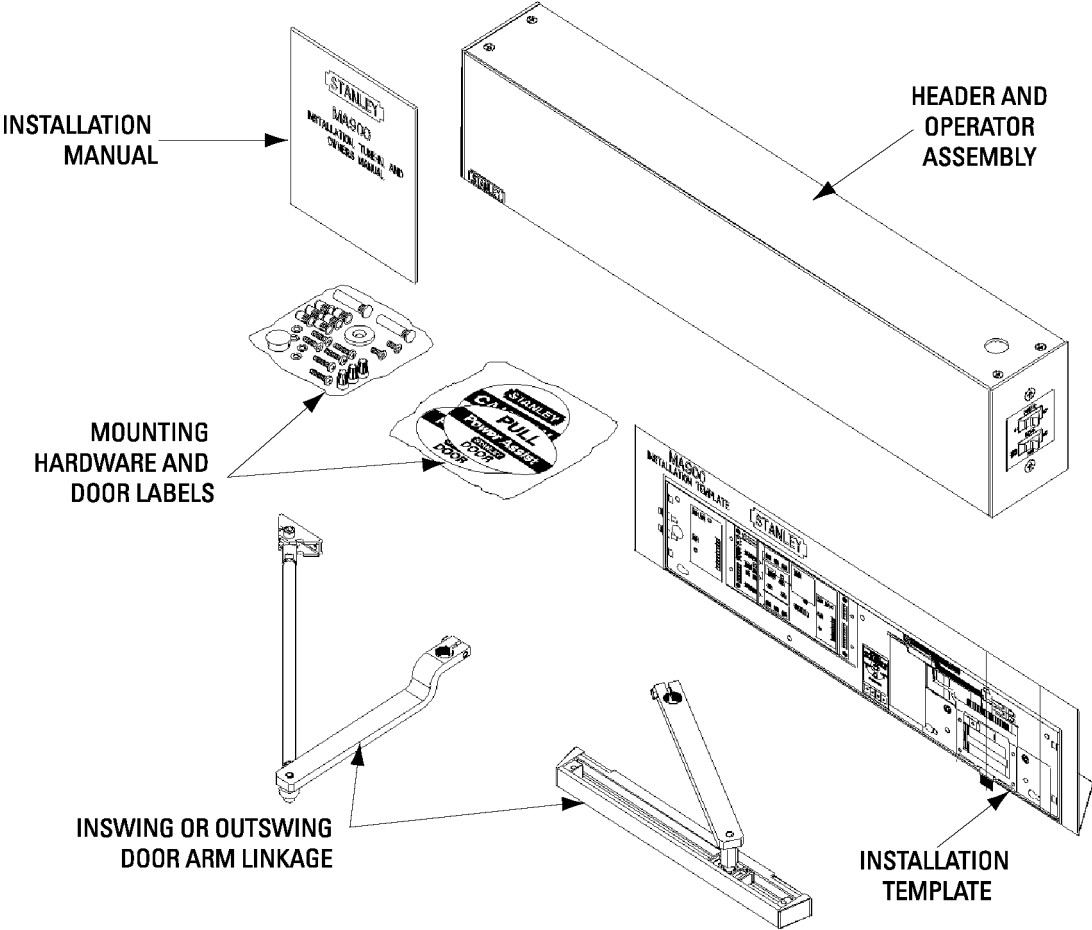











Fig. 7
MA900 Operator Kit Contents

Hardware

The installation and mounting hardware kit contains the following items:

- 8 X  1/4-20 Riv-nuts
- 2 X  1/4-20 X 1" long flat-head screws
- 6 X  1/4-20 X 1" long pan-head screws
- 4 X  1/4" lock washers
- 1 X  Operator arm retainer
- 3 X  1/4-20 X 9/16" long flat-head screws
- 2 X  1-5/8" long sexnuts (through bolts)
- 3 X  wire nuts
- 1 X  plug for 7/8" hole



ALL LABELS
REQUIRED BY
ANSI 156.19

Tools Required

You will need the following tools to install the Stanley MA900:

- Riv-nut tool for 1/4-20 Riv-nut and instructions
- Digital stopwatch
- Force gauge
- Number 2 Phillips screwdriver
- Small flat-blade screwdriver
- 3/32" and 3/8" Allen wrenches
- Center punch
- Hammer
- Tape measure
- Diagonal cutters (wire strippers)
- Step ladder
- Electric drill
- 1/8" drill bit
- 25/64" drill bit
- 3/8" drill bit
- Tape (for example, electrical tape) to hold template on door frame
- 1/2" box-end wrench
- 5/8" box-end wrench (or adjustable wrench)
- Carbide drill bits if the operator is being attached to a masonry surface.

Installation Procedures

Header Assembly Installation

Outswing Door – Mounting Preparation

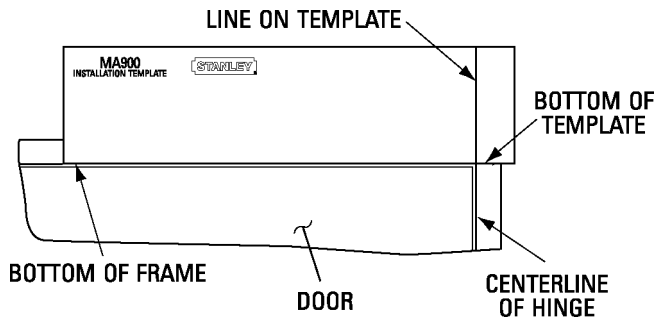

Fig. 8
Template alignment, outswing door

1. Select the right hand or left hand side of the installation template.
2. Position the template (see Fig. 8).
 - Separate the top of the template (for the header) from the bottom (for the door arm) along the perforation.
 - Align the bottom of the header template with the bottom edge of the door frame.
 - Align the indicated vertical line on the template with the center line of the hinge.
 - Use tape to hold the template in position.
3. Verify that the template is aligned properly; reposition if necessary.
4. Use a center punch to make a small depression on the frame at the center of each of the six hole locations marked "A" on the template.
5. If additional support backing is used, use a center punch to make a small depression at the center of each of the three hole locations marked "B" on the template.
6. If the electrical wire is to be run through the back of the header, use a center punch to make a small depression on the frame at the center of the hole location marked "C" on the template.
7. Remove the template.
8. Use a 1/8" bit to drill a pilot hole at each hole location; then use a 25/64" bit to drill each hole marked "A" out to the size of the Riv-nut.
9. Thread a Riv-nut fully onto the Riv-nut tool (see Fig. 9). (The Riv-nut tool is not supplied.)

10. Insert the Riv-nut into a mounting hole in frame.

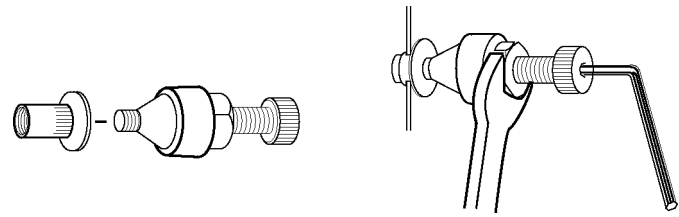

Fig. 9
Installation of Riv-nuts

11. Use a 3/8" Allen wrench and a 5/8" open-end wrench (or small adjustable wrench) as shown in Fig. 9. Hold the Allen wrench and turn the Riv-nut tool counterclockwise (ccw) until the Riv-nut is installed and tightened. Do not over-tighten; this will cause excessive deformation.
12. Remove the Riv-nut tool.
13. Install the remaining five Riv-Nuts in the holes on the frame.
14. Install 1/4-20 x 1" pan-head screws into the lower left and lower right Riv-nuts, and tighten about halfway.
15. If additional support backing is used, drill out the three hole locations marked "B" on the template to the desired size (hardware not provided).
16. If the electrical wire is to be run through the back of the header, drill the hole location marked "C" on the template to the desired size for wire.



The hole for the wire must be free of burrs and rough edges.

Inswing Door – Mounting Preparation

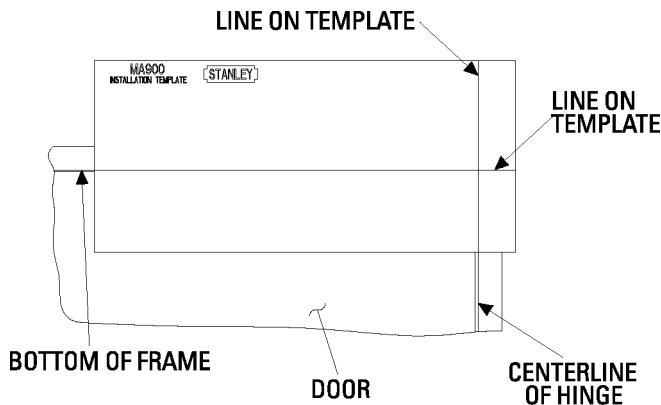

Fig. 10
Template alignment, inswing door

1. Make sure that proper additional support is installed as shown in Fig. 6.
2. Select the right hand or left hand side of the installation template.
3. Position the template (see Fig. 10).
 - Align the indicated horizontal line on the template with the top edge of the door frame.
 - Align the indicated vertical line on the template with the centerline of the hinge.
 - Use tape to hold the template in position.
4. Verify that the template is aligned properly; reposition if necessary.
5. Use a center punch to make a small depression at the center of each of the hole locations marked "A," "B," and "D" on the template.
6. If electrical wire is to be run through the back of the header, use a center punch to make a small depression at the center of the hole location marked "C" on the template.

7. Remove the template.
8. Use a 1/8" bit to drill a pilot hole at each of the two hole locations marked "D" on the template.
9. Drill the header mounting holes marked "A" and "B" to the desired size for mounting hardware (not supplied).
10. Install two mounting screws into lower left and lower right hand mounting holes and tighten about halfway.
11. If electrical wire is to be run through the back of the header drill the hole location marked "C" on the template to the desired size for wire.



The hole for the wire must be free of burrs and rough edges.

Install Header Assembly

1. Install the header assembly over the two screws, then slide it sideways so that the screw occupies the smaller part of the opening (see Fig. 11).



The hole for the wire must be free of burrs and rough edges.

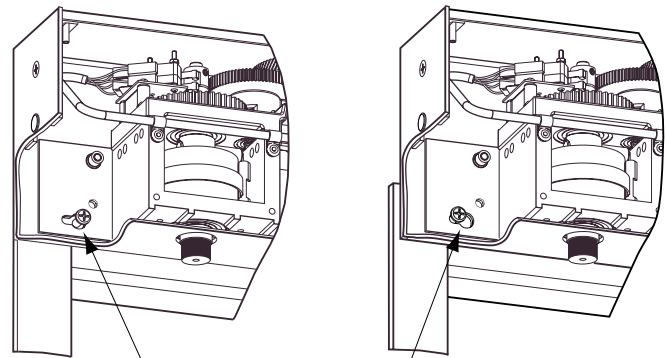

POSITIONING OF HOLE WITH SLOT

Fig. 11
Header mounting

2. Tighten the two screws so that they are snug but not fully tight.
3. Install the remaining four screws and 1/4" lock washers so that they are snug but not fully tight.
4. Fully tighten all mounting screws.

Connect to 117 VAC Power Supply



The electrical connection must be made by a qualified USEA electrician. See Electrical Specifications page 15, for requirements.

1. Depending on the application, run the electrical wire through either the hole in top of the header (wall outlet), or the hole in the back of the header (concealed).



Make sure that the wire access hole on the operator is free of burrs and rough edges.

2. Seal the unused hole with the plug provided.
3. Connect the wires to the leads on the power harness (see Fig. 12).

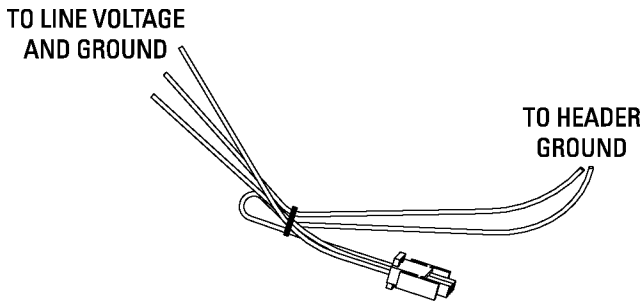

Fig. 12
Wiring harness

Install Door Arm Assembly - Outswing Door



Do not wear rings, watches or loose clothing while installing or servicing the door operator.

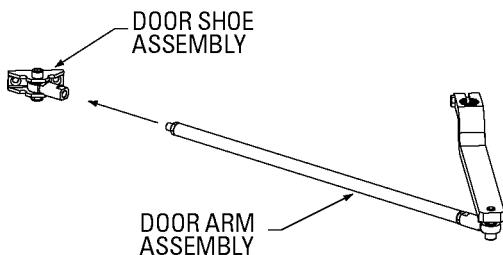

Fig. 13
Outswing door arm assembly

In most cases the door should open to a minimum of 90°. The door arm is attached to the door by means of a door shoe (see Fig. 13). The location of the door shoe varies depending on the depth of the reveal. Use the template provided to position the door shoe.

1. Set the power switch on the side of the header to the "ON" position (power up).
2. Set the mode switch to Hold Open. The operator shaft rotates to its mechanical stop (fully open) and stays there. Verify that the dowel pin on the operator shaft is against the stop (see Fig. 14).

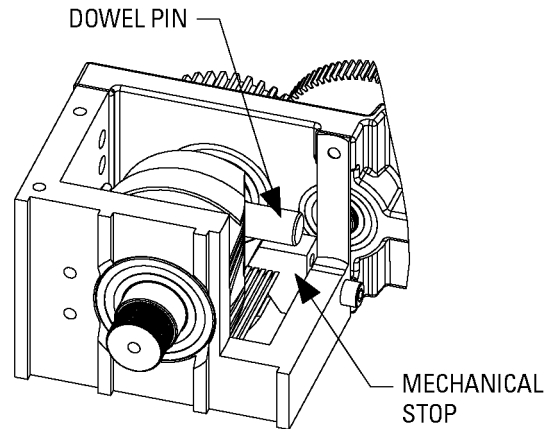

Fig. 14
Full-stop position



If the operator shaft does not come to a full stop with the dowel pin against the stop, decrease the back check time, as described in step 2 of Door Opening Adjustments section of this manual. Increase the stall force as described in step 3 of Door Opening Adjustments section of this manual.

3. Select the right hand or left hand side of the door arm installation template.
4. Position the template:
 - Align the top of the template with the top edge of the door.
 - Align the indicated vertical line on the template with the center line of the hinge.
5. Measure the depth of the reveal.
6. Identify and mark the pair of hole locations that corresponds to the reveal depth on the template.
7. Use tape to attach the template to the door.
8. Verify that the template is aligned properly; reposition if necessary.
9. Use a center punch to make a small depression in the door at the center of each of the two hole locations on the template.

10. Remove the template.
11. If the door is made of metal, use a 25/64" bit to drill holes for the Riv-nuts supplied, or a 3/8" bit to drill holes for the 1-5/8" sex nuts supplied.
12. If the door is made of wood, use a 3/8" bit to drill holes for the 1-5/8" sex nuts supplied.
13. Attach the door shoe to the door using the two 1/4-20 x 1" flat-head screws supplied.
14. Thread the rod into the door shoe.
15. Open the door to the desired fully open position.
16. Slide the door arm onto the operator shaft.

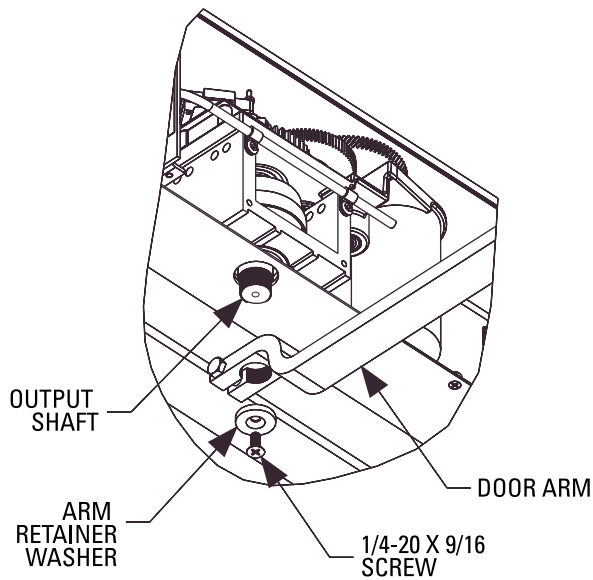

Fig. 15
Attachment of arm to operator shaft

17. Install the operator arm retainer washer and screw to the bottom of the operator shaft (see Fig. 15).
18. Use a 1/2" box end wrench to tighten the bolt that attaches the door arm to the operator shaft.

★ *Make certain this bolt is fully tight.*

19. Set the power switch on the side of the header to the "Off" position (power down).
20. Test door operation by manually pushing the door to its fully open position.
 - If the door opens to the desired angle, go to Tune-In Procedures section of this manual.
 - If the door does not open to the desired angle, loosen the bolt on the operator output arm. Power up, set the mode switch to Hold Open, and repeat the procedure from step 15.

Install Door Arm Assembly - Inswing Door



Do not wear rings, watches or loose clothing while installing or servicing the door operator.

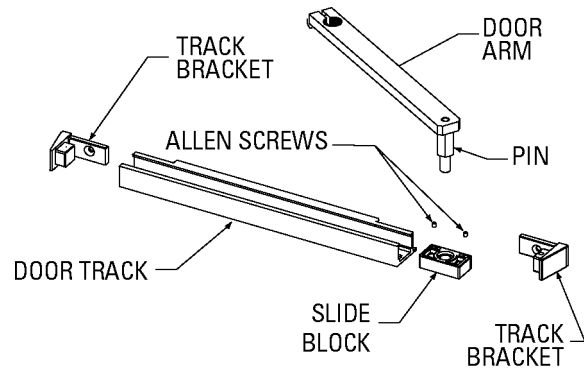

Fig. 16
Inswing door arm assembly

See Fig. 16. In most cases the door should open to a minimum of 90°. The door arm terminates in a block, which travels in a track that is secured to the door by two brackets.

1. Power up.
2. Set the mode switch to Hold Open. The operator shaft rotates to its mechanical stop (fully open) and stays there. Verify that the dowel pin on the operator shaft is against the stop (see Fig. 17).

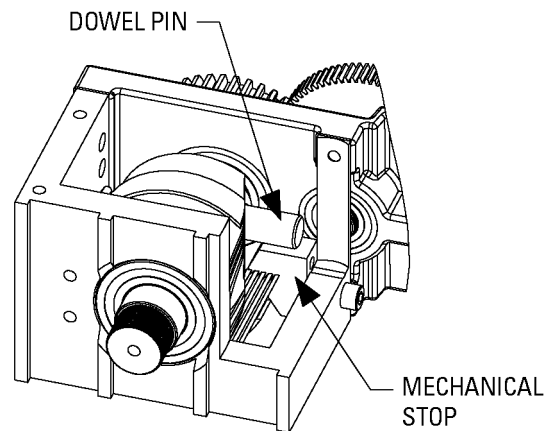

Fig. 17
Full stop position

★ *If the operator shaft does not come to a full stop with the dowel pin against the stop, decrease the back check time, as described in step 2 of Door Opening Adjustments section of this manual. Increase the stall force as described in step 3 of Door Opening Adjustments section of this manual.*

3. Identify the two 1/8" holes made previously on the door for mounting the track brackets.
4. If the door is made of metal, use a 25/64" bit to drill holes for the Riv-nuts supplied, or a 3/8" bit to drill holes for the sex nuts supplied.
5. If the door is made of wood, use a 3/8" bit to drill holes for the sex nuts supplied.
6. Attach the two track brackets, using the 1/4-20 x 1" flat-head screws supplied.
7. Assemble the slide block into the door track.
8. Assemble the Allen screws into the slide block so that the block slides smoothly and has no side-to-side movement.
9. Slide one end of the track onto the track bracket as shown in Fig. 18.

10. Press the other end of the track onto the track bracket as shown in Fig. 19 and assemble using the two 1/4-20 x 9/16" flat-head screws supplied.
11. Tighten the screws fully.
12. Assemble the pin into the door arm.
13. Assemble the door arm and pin assembly into the slide block in the door track.
14. Assemble the door arm onto the operator output shaft. Do not tighten the hex bolt.
15. Assemble the operator arm retainer using the 1/4-20 x 9/16" flat-head screw supplied.
16. Open the door to the desired position.
17. Tighten the bolt on the door arm.
18. Set the mode switch to the Day position.
19. Power down.
20. Test door operation by manually pushing the door to its fully open position.
 - If the door opens to the desired angle, go to Tune-In Procedures section of this manual.
 - If the door does not open to the desired angle, loosen the bolt on the operator output arm. Power up, set the mode switch to Hold Open, and repeat the procedure from step 16.

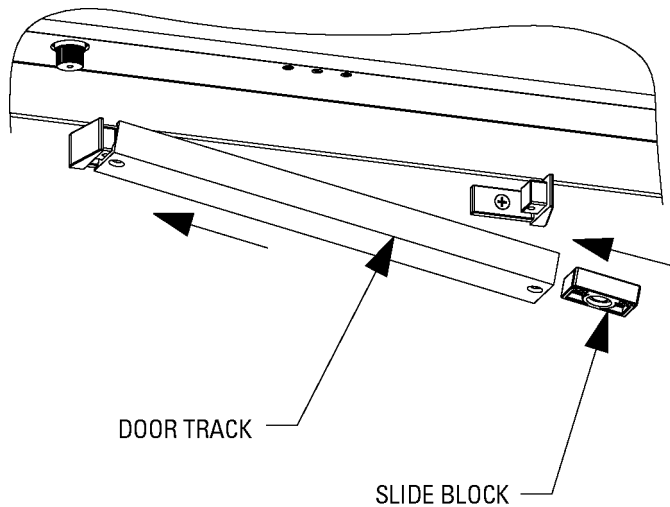

Fig. 18
Sliding one end of track onto track bracket

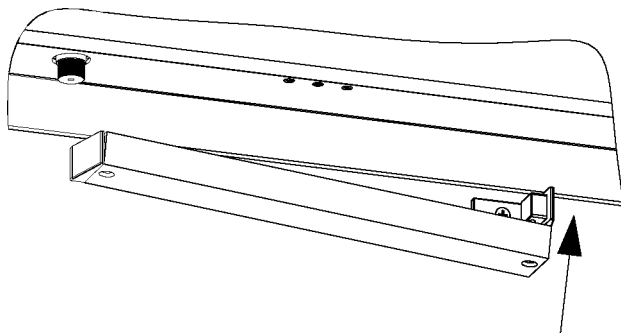



Fig. 19
Pressing other end of track onto track bracket

Connect Actuation Devices

See the electrical specifications below for specific wiring requirements.

Electrical Specifications

The MA900 can be wired to accommodate several applications requirements. Figures 21 through 25 show how to wire the MA900 for each specific application.



Shut off power at a circuit breaker, or unplug the operator, before making any changes to wiring.

Power Requirements

See Fig. 20 for proper location of concealed wiring.

117 VAC, 15 Amp service for one or two operators.

Dedicated 20 Amp service for three or four operators.



If an electrical cord is used to power the operator, it must be UL Listed.

The electrical outlet and wire should be mounted out of reach. Recommendation: at least 7 feet above the floor.

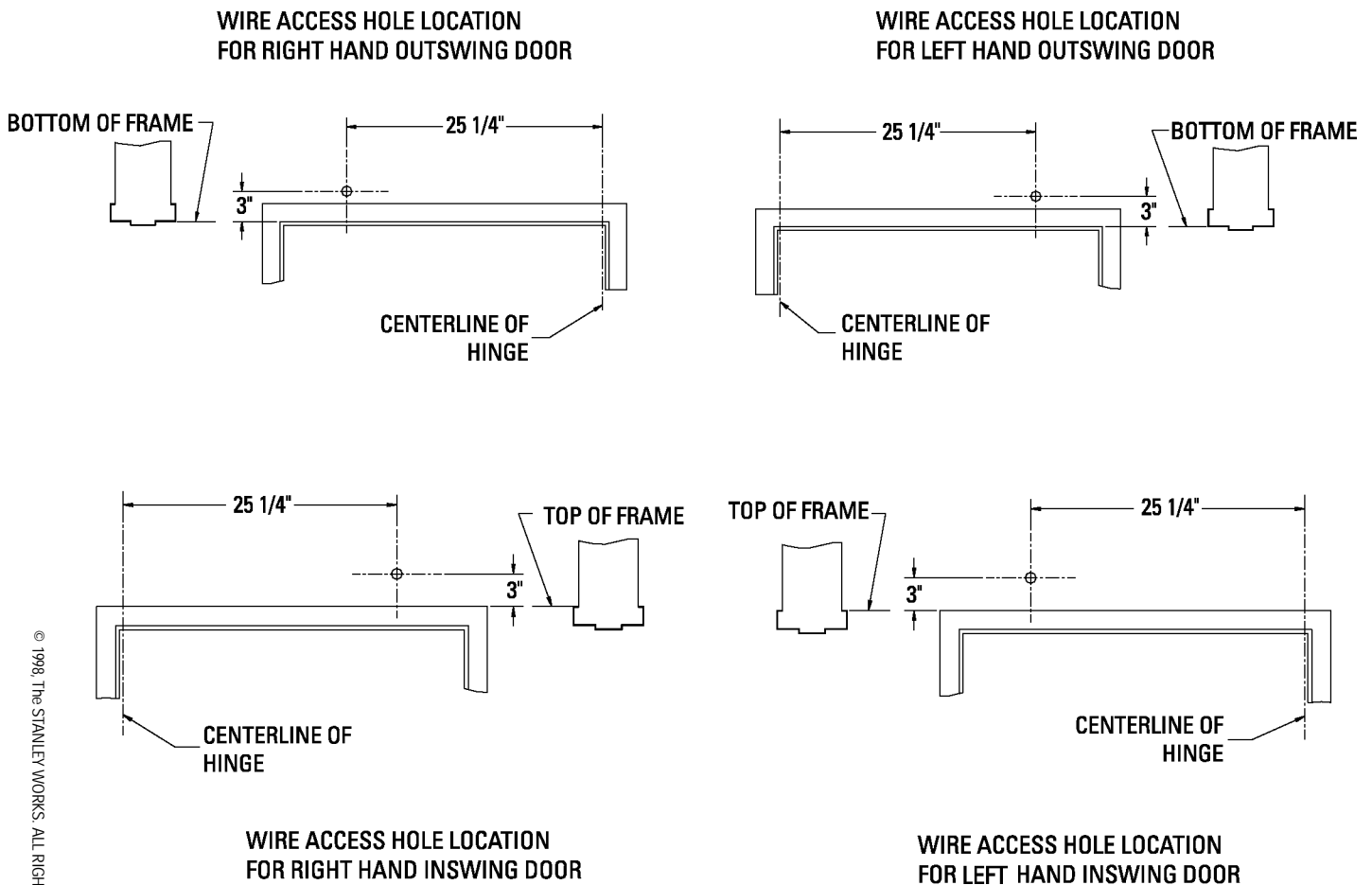

© 1998, The STANLEY WORKS. ALL RIGHTS RESERVED.

Fig. 20
Position of wire access hole for concealed wiring

Wiring Diagrams

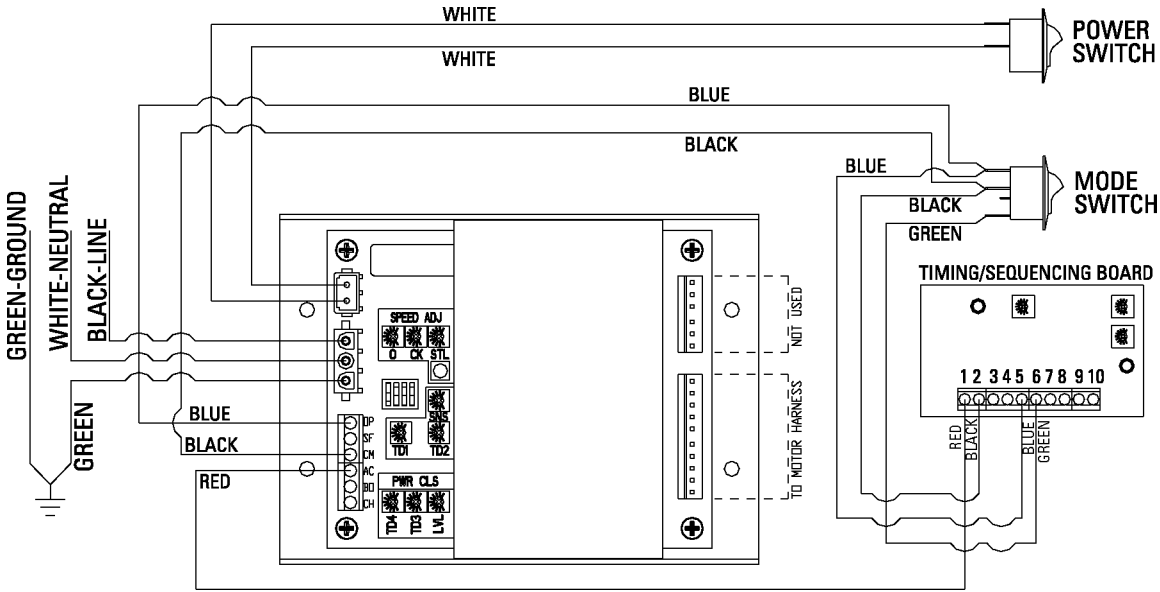

Fig. 21
As wired from factory

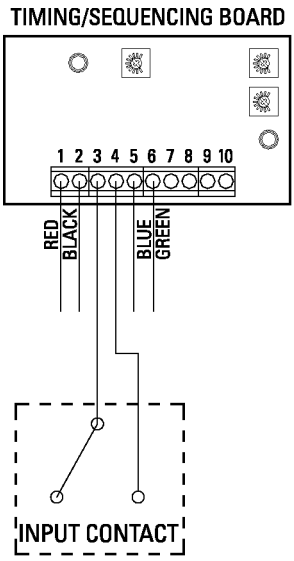

Fig. 22
Wiring diagram for single door

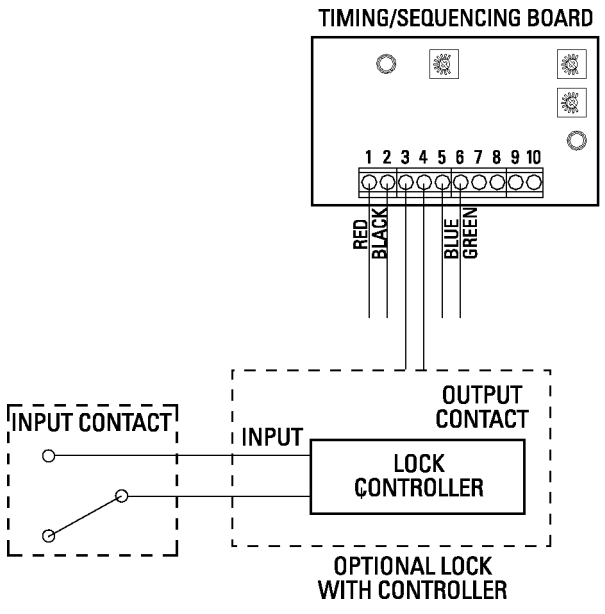

Fig. 23
Wiring diagram for single door with electric lock and controller

© 1998, The STANLEY WORKS. ALL RIGHTS RESERVED.

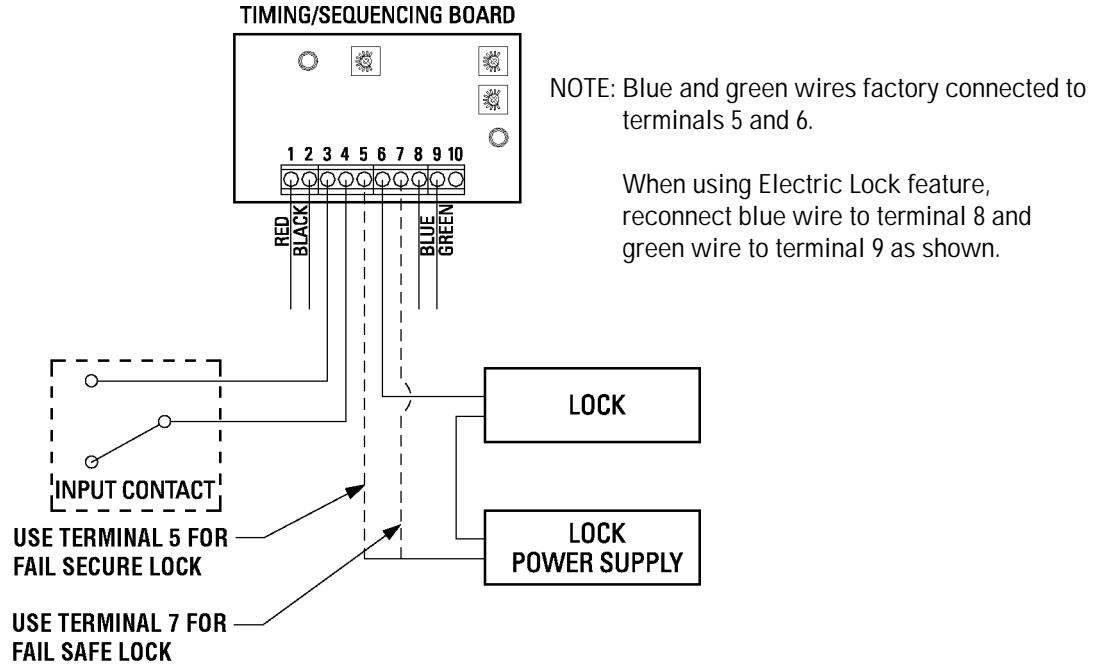

Fig. 24
Wiring diagram for single door with electric lock (no controller)

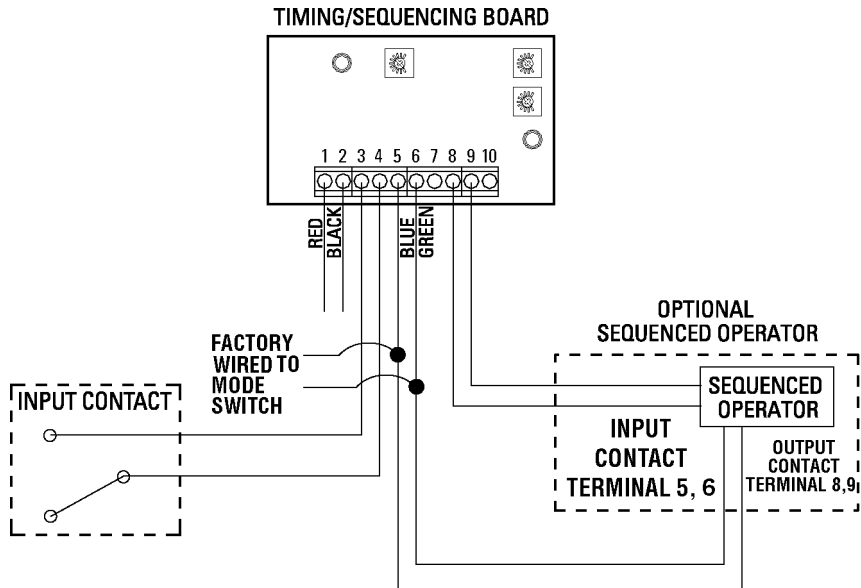

Fig. 25
Wiring diagram for vestibule function

Tune-In Procedures

Tuning-in is the process of adjusting the operating characteristics of the Stanley MA900 — opening time, closing time, etc.

The door must operate in accordance with the ANSI (American National Standards Institute) Standard for Power Assist and Low Energy Power Operated Doors, A156.19.



The tune-in procedures must be followed completely, and in the order presented here, to make certain that the door is in full compliance with the ANSI standard.

Check your local code requirements to assure compliance in your area.

2. Power down.
3. Using a 3/32" Allen wrench, loosen the set screw on the back-check cam (top cam) (see Fig. 26).
4. Use the Allen wrench to rotate the back-check cam.
5. On a right-outswing or left-inswing door, rotate the cam counter clockwise (ccw) to increase, clockwise (cw) to decrease, the back-check angle.
6. On a left-outswing or right-inswing door, rotate the cam cw to increase, ccw to decrease, the back-check angle.
7. Use the 3/32" Allen wrench to tighten the Allen screw.
8. Power up.
9. Test door operation by setting the mode switch to Hold Open, or by using an external actuation device. If necessary, power down and readjust the cam.

Cam Adjustments



Do not wear rings, watches or loose clothing while installing or servicing the door operator.

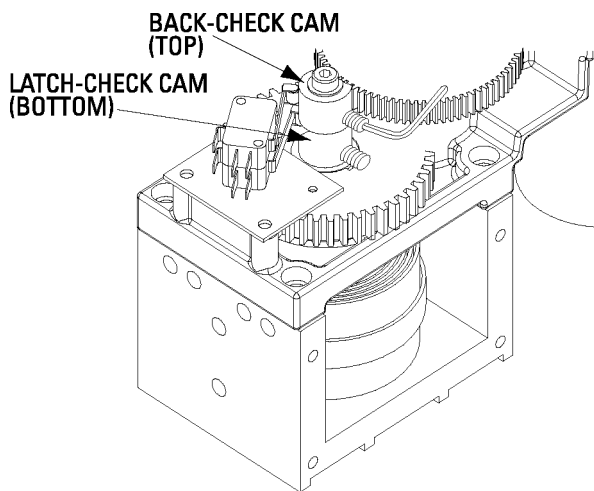

Fig. 26

Overall view of operator assembly, with callouts to cams

Back-Check Cam

The door opens at normal speed until it is almost fully open; then back check is activated, and the door moves slowly to the fully open position. The ANSI standard specifies that the back check must not occur before the door is open at least 60°. Normally the back check occurs about 20° before the door reaches the fully open position.

1. Power up. Test door operation by setting the mode switch to Hold Open, or by using the external actuation device. Make sure that back check occurs after the door is open at least 60°, and at least 10° before the door is fully open. If it is in compliance with the ANSI standard, go to Latch-Check Cam, below. If it is not in compliance with the ANSI standard, go to step 2.

Latch-Check Cam

The door closes at normal speed until it is almost fully closed; then latch check is activated and the door moves slowly to the fully closed position. The ANSI standard specifies that the latch check must occur 10° before the door reaches the fully closed position.

1. Power down. Test door operation by moving the door to the open position and releasing the door. Make sure that the latch check occurs 10° before the door is fully closed. If it is in compliance with the ANSI standard, go to Adjust Opening and Closing Times, below. If it is not in compliance with the ANSI standard, go to step 2.
2. Power down.
3. Using a 3/32" Allen wrench, loosen the set screw on the latch-check cam (bottom cam) (see Fig. 26).
4. Use the Allen wrench to rotate the latch-check cam.
 - On a outswing or inswing door, rotate the cam ccw to increase, cw to decrease, the latch-check angle.
 - On a left-outswing or right-inswing door, rotate the cam clockwise to increase, counter clockwise to decrease the latch-check angle.
5. Use the 3/32" Allen wrench to tighten the Allen screw.
6. Power up.
7. Test door operation by manually pushing the door open and checking the position at which latch check occurs. If necessary, power down and readjust the cam.

Adjust Opening and Closing Times



Adjusting elements are close to live electrical parts.

Table 1.

Minimum opening time to back check or 80°, which ever occurs first, or minimum closing time from 90° to latch check or 10°. Back check shall not occur before 60° opening.

"D" Door Leaf Width - in. (mm)	"W" Door Weight in lb (kg)				
	100 (45.4)	125 (56.7)	150(68.0)	175(79.4)	200(90.7)
30 (762)	3.0*	3.0	3.0	3.0	3.5
36 (914)	3.0	3.5	3.5	4.0	4.0
42 (1067)	3.5	4.0	4.0	4.5	4.5
44 (1118)	4.0	4.5	4.5	5.0	5.5

* The value for the 30 in. wide, 100 lb door actually calculates to 2.5 sec with rounding. 3.0 sec was used as a more conservative value.

Doors of other weights and widths can be calculated using the formula:

$$T = D\sqrt{W} / 133 \text{ in US units}$$

$$T = D\sqrt{W} / 2260 \text{ in SI (metric) units}$$

Where: T = Time, sec
D = Door width, in. (mm)
W = Door weight, lb. (kg)

Matrix values for "T" time have been rounded up to the nearest half sec. These values are based on kinetic energy of 1.25 lb-ft.

The ANSI standard specifies that doors be adjusted so that:

- Closing time from 90° to 10° (latch check) is 3 sec or longer, as stated in Table 1.
- The time from 10° to fully closed is not less than 1.5 sec.

**ADJUST
RHEOSTAT**

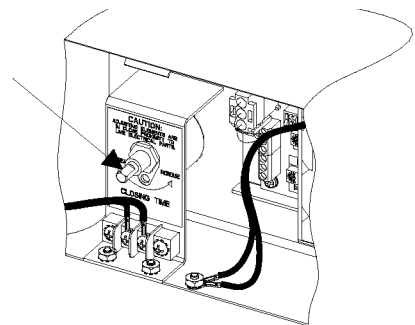

Fig. 27
Closeup of rheostat

Closing time is controlled by the rheostat. Use your fingers to rotate the rheostat knob ccw to increase, cw to decrease, the closing time (see Fig. 27).

Controller Adjustments



Adjusting elements are close to live electrical parts.

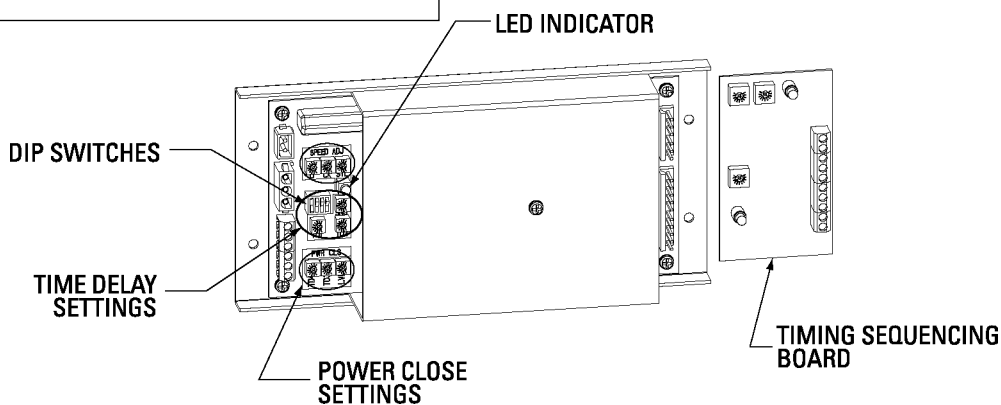

Fig. 28
Over-all view of controller

See Figure 28.
The next several adjustments are made in the controller.

Door Opening Adjustments

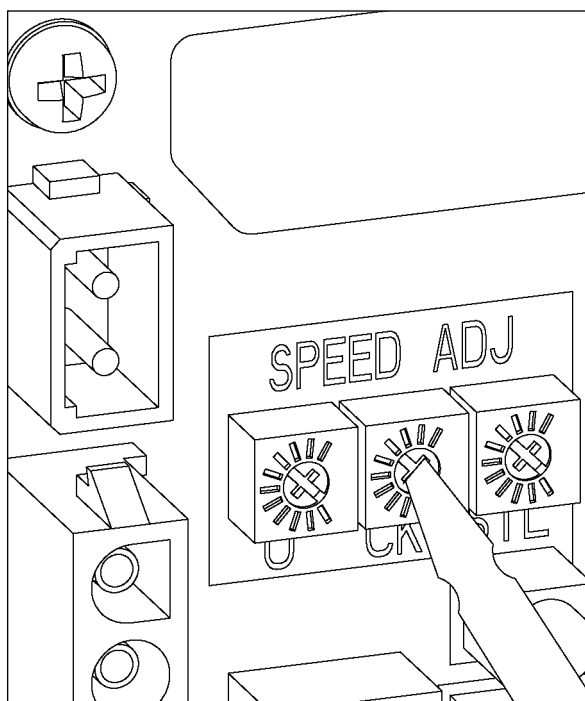

Fig. 29
Closeup of the three potentiometers*

1. *O (opening time)*: Opening time to back check or 80°, whichever occurs first, must be 3 sec or longer, as specified in Table 1. Turn the potentiometer cw to decrease, ccw to increase, the opening time.
2. *CK (back-check time)*: Back-check time is the time it takes the door to move from the back check to fully open. The total time from fully closed to fully open must be 4 sec or longer. For most applications, the total time fully closed to fully open should be the opening time (set in step 1) plus 1 sec. Turn the potentiometer ccw to increase, cw to decrease, the back check time.
3. *STL (stall force)*: The operator applies stall force to the door while it is being held open to prevent it from creeping closed. Adjust the stall force so that the operator applies enough force to prevent the door from creeping closed. Turn the potentiometer cw to increase, ccw to decrease, the stall force.



While the door is in Stall mode, the LED indicator is on.

Use a small screwdriver to make the following three adjustments (see Fig 29.). Use a stopwatch for time measurements. The ANSI standard specifies that doors be adjusted as follows:

Dip Switches

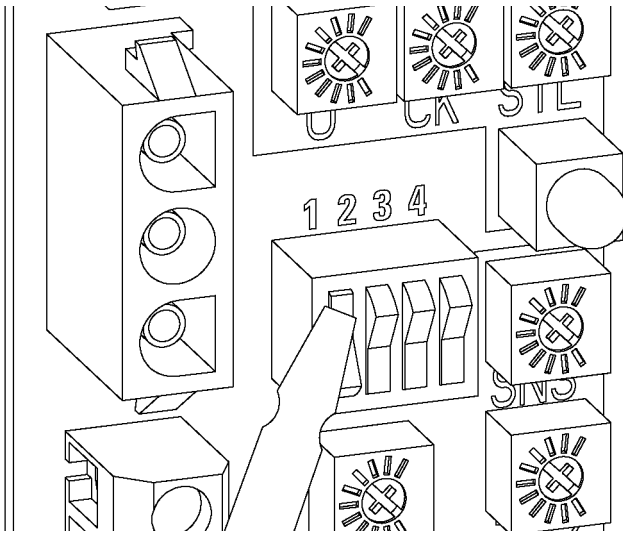

Fig. 30
Dip switches

Four operating features are controlled by dip switches (see Fig. 30). A dip switch has two positions, up (A) and down (B). Use a small screwdriver or a pencil point to set the dip switches.

From left to right these are:

1. *Lock Delay*: Delays the operation of the door 1/2 sec to allow a lock to release.
2. *Power Close*: Used to assist door closing when stack pressure exerts an outward or inward force that keeps the door from closing fully.
3. *Magic-Touch™*: Allows the door to be actuated by a slight movement of the door.
4. *Power Close Cancel*: Turns off Power Close after a specified time.

The features are:

1. A Lock Delay is Off
B Lock Delay is On
2. A Power Close is Off
B Power Close is On
3. A Magic-Touch™ is On
B Magic-Touch™ is Off
4. A Power Close Cancel is Off
B Power Close Cancel is On



While Power Close is active, the LED indicator is on, and the Magic-Touch™ feature is inactive.

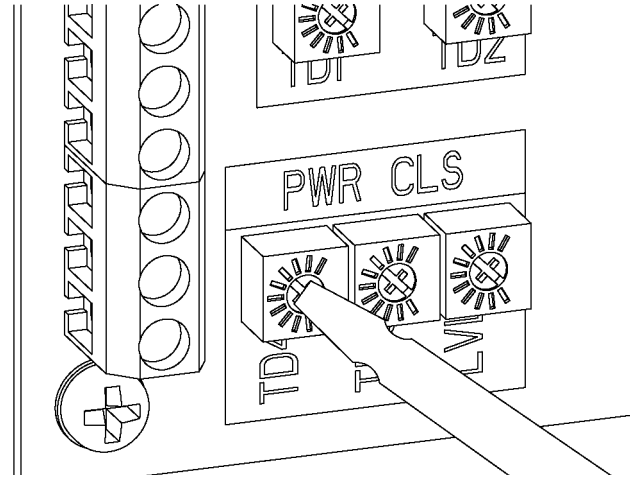

Fig. 31
Power Close potentiometers

The Power Close feature is controlled by three potentiometers (see Fig. 31):

1. *TD3 Enable Time Delay*: Controls the time between the start of the door close to the actuation of Power Close. This time must be set so that Power Close is actuated when the door is approximately one inch from fully closed. Turn the potentiometer cw to increase, ccw to decrease, the time delay.
2. *TD4 Cancel Time Delay*: Controls the time for which Power Close remains active. Turn the potentiometer cw to increase, ccw to decrease, the time.
3. *LVL Power Close Force*: Controls the amount of force applied by the Power Close feature. Turn the potentiometer cw to increase, ccw to decrease, the Power Close force.

Swing-Safe Technology

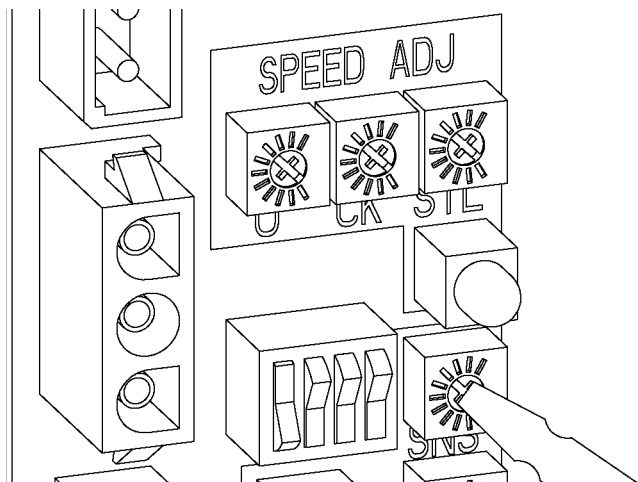

Fig. 32
Reversal force potentiometer

This electronic safety control will sense an obstruction during the opening cycle of the door. The operator will immediately reverse the door direction, allowing time for the obstruction or person to clear the swing path area of the door.

Reversal force SNS: Controls the amount of force required to cause the door to stop and reverse. The ANSI standard specifies that this force must be less than 15 lb applied 1 inch from the latch edge of the door at any point in the cycle. Use a force gauge to measure the force. Turn the potentiometer cw to decrease, ccw to increase, the reversal force. (see Fig. 32).

Operation Timers

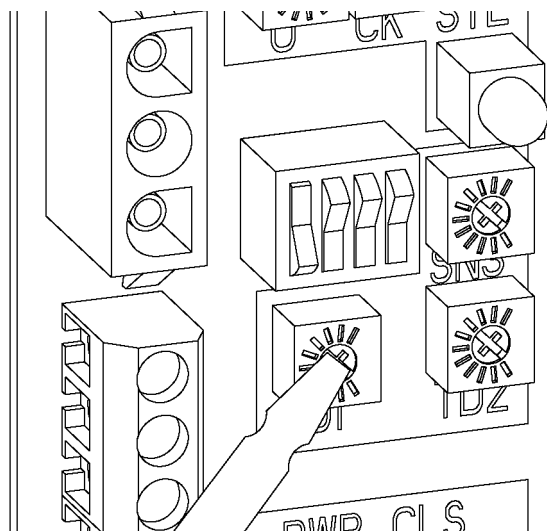

Fig. 33
Operational timers

1. **Hold Open Time – External Switch:** TD1 controls the time interval from receipt of the signal from an actuator (push plate or radio-frequency transmitter) to the start of the door-close operation. The time delay is adjustable from 1-30 sec. The ANSI Standard requires that the delay be set for a minimum of 5 sec. Turn the potentiometer cw to increase, ccw to decrease, the Hold Open time.
2. **Hold Open Time – Magic-Touch™:** TD2 controls the time interval from Magic-Touch™ actuation to the start of the door-close operation. The time delay is adjustable from 1-30 sec. The ANSI Standard requires that the time delay be set for a minimum of 5 sec. Turn the potentiometer cw to increase, ccw to decrease, the Hold Open time.

Optional Sequencing Timers

DELAY, DELAY TIMER FOR VESTIBULE OR LOCK

#1, FIRST ACTUATION HOLD TIMER

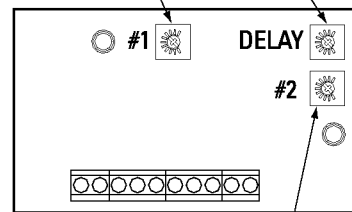

#2, SECOND ACTUATION HOLD TIMER

Fig. 34
Sequencing timers

Single Door Function

Each potentiometer on the timing and sequencing module (see Fig. 34) should be set to its minimum setting; *fully ccw*.

Vestibule Function

Delay: Controls the time delay between the start of the opening operation of the first door and the start of the opening operation of the second door. Turn the potentiometer cw to increase, ccw to decrease, the time delay.

#1: Controls the length of time the first actuation signal is held. The potentiometer should be set to the minimum; *fully ccw*.

#2: Controls the length of time the second actuation signal is held. The potentiometer should be set to the minimum; *fully ccw*.

Electric Lock Function

Delay: Controls the time delay between the lock signal and the start of the opening operation of the second door. The adjustment should be set so that the lock has enough time to unlock before the door operator begins the open cycle. Turn the potentiometer cw to increase, ccw to decrease, the time delay.

#1: Controls the length of time the first actuation signal is held. This adjustment should be set to hold the lock open long enough for the door operator to open. Turn the potentiometer cw to increase, ccw to decrease, the time delay.

#2: Controls the length of time the second actuation signal is held. The potentiometer should be set to the minimum; fully ccw.

Safety Checks

The following safety checks must be made daily to assure proper door operation:

- For safe operation, refer to the Daily Safety Check Sheet for safety procedures. If you need a copy, call your local Stanley distributor.
- Test the doors daily, and after any power outage. Verify operation of any sensors and/or mats.
- Check the condition of the door, hinges, and safety decals, as well as rails, finger guards, door pivots and mat moldings (if applicable).
- If there are any problems, DISCONTINUE DOOR OPERATION IMMEDIATELY! Notify your local authorized Stanley distributor for repair.

Safety Decals



The installation is not complete until the safety decals are in place.

This section provides procedures for installing the MA900 safety decals. The decals will help pedestrians to use the doors safely.

Decals Included

The safety decal kit contains the items shown in Fig. 35, below:

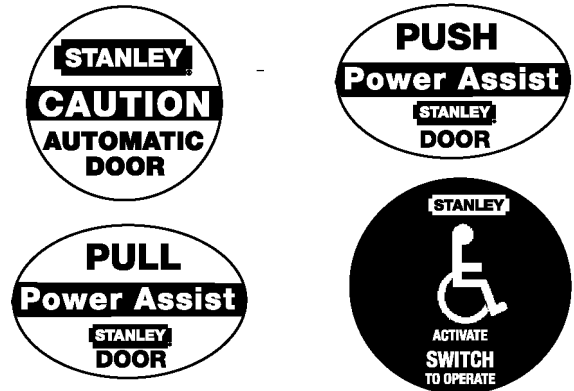

Fig. 35
Safety decals

Decal Placement Requirements

The requirements set forth in the ANSI Standard A156.19 are summarized below.

All low energy doors shall be marked with signs, one on each side of the door, with the words CAUTION AUTOMATIC DOOR. Each sign shall be mounted on the door at a height 58" +/- 5" (1475 +/- 125 mm) from the floor to the center line of the sign. Each sign shall be a minimum of 6" (152 mm) in diameter, and have black lettering on a yellow background.

Decal Installation Procedures

1. Thoroughly clean the door surface where the decal is to be mounted.
2. Locate the center line of the decal, 58" +/- 5" above the finished floor.
3. Remove the smaller section of the decal backing.
4. Hold the decal up to the door at the desired location. Be sure that the decal is straight.
5. Apply the sticky surface of the top of the decal to the door.
6. Use a rigid, straight-edged tool (for example, a ruler) to smooth the top of the decal on the door.
7. Slowly remove the larger section of the decal backing, using the rigid, straight-edged tool as a squeegee. This will force out air bubbles.

When an external actuator (e.g., a wall switch) is used to actuate the door operator, the door shall be provided with signs on both

sides with a message **ACTIVATE SWITCH TO OPERATE**. The lettering shall be white and the background shall be blue (see Fig. 36).

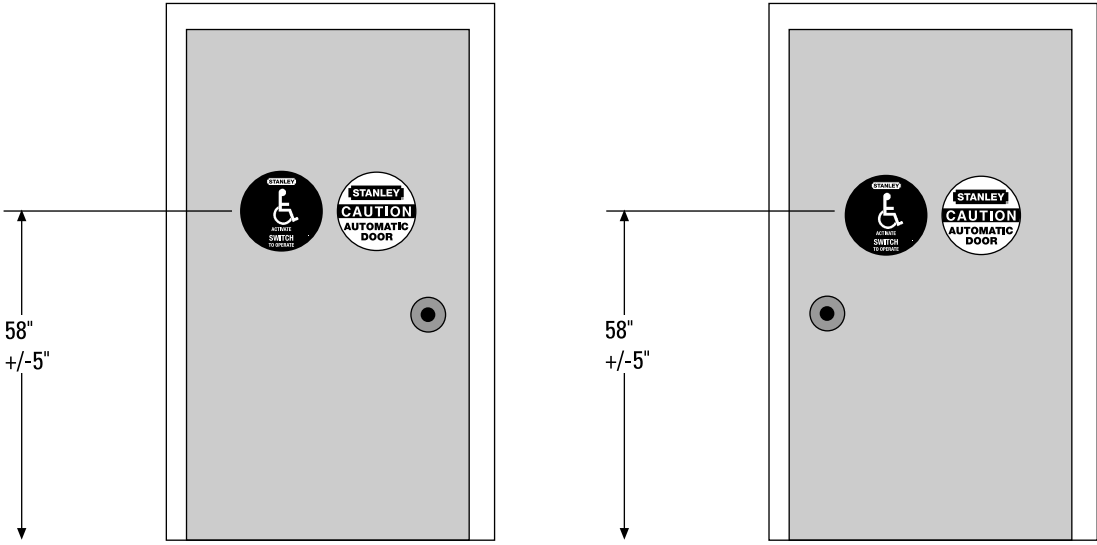

Fig. 36
Front and back views of door with decals in place for external actuation

When door motion is used to actuate the door operator (Magic-Touch™), the door shall be provided with the message **PUSH TO OPERATE** on the push side, and the message **PULL TO OPERATE**

on the pull side. The lettering shall be white and the background shall be blue (see Fig. 37).

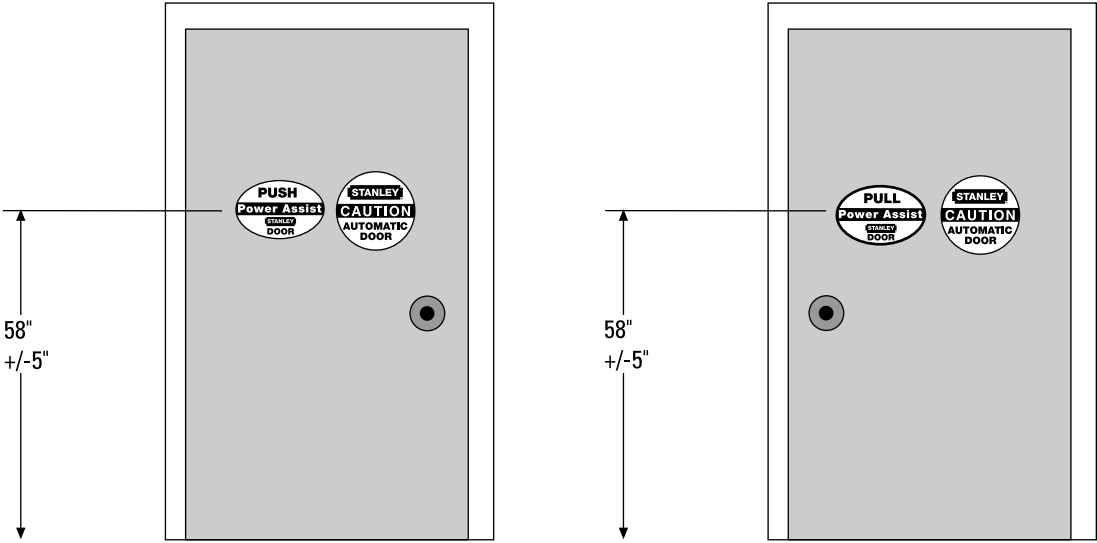

Fig. 37
Front and back views of a door with decals in place for Magic-Touch™

Door will not open, or will not fully open.

1. *Is the door locked?*
 Yes • Unlock the door.
 No • Step 2.
2. *Is the power switch set to OFF?*
 Yes • Set the power switch to the on position.
 No • Step 3.
3. *Is the mode switch set to NIGHT?*
 Yes • Set the mode switch to DAY.
 No • Step 4.
4. *Set the mode switch to HOLD OPEN. Does door open?*
 Yes • Re-tune the operator.
 - Rotate fully ccw the output time DELAY potentiometer on the sequencing board.
 - Step 5.
 No • Check circuit breaker at electrical panel.
 - Check the fuse on the control board and replace if necessary.
 - Have a qualified electrician check the power connection.
5. *Do any green or red LEDs light with input signal?*
 Yes • Step 6.
 No • Check connections to the sequencing module.
 - Check connections to the control board.
 - Check connections to actuation devices and re-wire or replace if necessary.
6. *Does the door open to the desired fully open position when manually operated?*
 Yes • Step 7.
 No • Remove and replace the door arm and re-tune the operator.
 - Step 7.
7. *Does the door operate freely when manually opened.*
 Yes • Contact authorized Stanley distributor.
 No • Verify door arm shoe (outswing) or track (inswing) location and re-install if necessary.
 - Verify operator header mounting location and re-install if necessary.
 - Disconnect the door arm from the operator. If door does not swing freely replace or repair worn or damaged door components and re-install the door arm.

The door will not close or will not fully close.

1. *Is the Mode Switch set to HOLD OPEN?*
 Yes • Set the Mode Switch to DAY.
 No • Step 2.
2. *Does wind or stack pressure keep the door from closing?*
 Yes • Turn on the POWER CLOSE feature and re-tune the operator.
 No • Step 3.
3. *Does the LED on the timing/sequencing module stay on?*
 Yes • Rotate fully ccw the input time delay relay, #1, on the sequencing module.
 - Check the connections to the timing/sequencing module.
 - Check the connections to the control board.
 - Check connections to actuation devices and re-wire or replace if necessary.
 - Contact authorized Stanley distributor for replacement.
 No • Step 4.
4. *Does the door operate freely when manually opened and closed?*
 Yes • Contact authorized Stanley distributor for replacement.
 No • Verify door arm shoe (outswing) or track (inswing) location and re-install if necessary.
 - Verify operator header mounting location and re-install if necessary.
 - Disconnect the door arm from the operator. If door does not swing freely replace or repair worn or damaged door components and re-install the door arm.

The door does not operate smoothly.

1. *Are there any obstructions in the swing path of the door? (e.g. Rug rubbing on the bottom of the door)*
 Yes • Remove obstruction.
 No • Re-tune the operator.
 - Step 2.
2. *Does the door operate freely when manually opened and closed?*
 Yes • Contact your authorized Stanley distributor for replacement.

- No
- Verify door arm shoe (outswing) or track (inswing) location and re-install if necessary.
 - Verify operator header mounting location and re-install if necessary.
 - Disconnect the door arm from the operator. If door does not swing freely replace or repair worn or damaged door components and re-install the door arm.

- Verify operator header mounting location and re-install if necessary.
- Disconnect the door arm from the operator. If door does not swing freely replace or repair worn or damaged door components and re-install the door arm.
- Disconnect the door arm from the operator. If door does not swing freely replace or repair worn out or damaged components and re-install the door arm as described in the manual.

The door continues to open and close.

1. *Are there any obstructions in the swing path of the door? (e.g. Rug rubbing on the bottom of the door)*

Yes • Remove obstruction.

No • Re-tune the operator.
• Step 2.

2. *Does the door fully open when manually operated?*

Yes • Step 3.

No • Remove and replace the door arm and re-tune the operator as described in the manual.
• Step 3.

3. *Does the door operate freely when manually opened and closed?*

Yes • Contact your authorized Stanley distributor for replacement.

No • Verify door arm shoe (outswing) or track (inswing) location and re-install if necessary.
• Verify operator header mounting location and re-install if necessary.
• Disconnect the door arm from the operator. If door does not swing freely replace or repair worn or damaged door components and re-install the door arm.

The door is very noisy during operation.

1. *Are there any obstructions in the swing path of the door? (e.g. Rug rubbing on the bottom of the door)*

Yes • Remove obstruction.

No • Step 2.

2. *Does the door operate freely when manually opened and closed?*

Yes • Contact authorized Stanley distributor for replacement.

No • Verify door arm shoe (outswing) or track (inswing) location and re-install if necessary.

The door operates too quickly, too slowly, or seems to be out of adjustment.

1. *Are there any obstructions in the swing path of the door? (e.g. Rug rubbing on the bottom of the door)*

Yes • Remove obstruction.

No • Re-tune the operator.
• Step 2.

2. *Does the door fully open when manually operated?*

Yes • Step 3.

No • Remove and replace the door arm and re-tune the operator.
• Step 3.

3. *Does the door operate freely when manually opened and closed?*

Yes • Re-tune the operator as described in the manual.

• Contact your authorized Stanley distributor for replacement.

No • Verify door arm shoe (outswing) or track (inswing) location and re-install if necessary.

• Verify operator header mounting location and reinstall if necessary.

• Disconnect the door arm from the operator. If door does not swing freely replace or repair worn or damaged door components and re-install the door arm.



© 1998, The STANLEY WORKS. ALL RIGHTS RESERVED.