

Stanley Access Technologies



MC521 Controller
Installation and Operation Manual

Includes Instruction for:

DuraGlide™ 2000/3000, 5200/5300, DuraGuard™ and DuraStorm™
Automatic Slide Door Systems

204003

Rev. D 3/11/07

Prohibition on Copying

Any unauthorized reproduction, disclosure or distribution of copies by any person of any portion of this work may be a violation of copyright law of the United States of America and other countries, could result in the awarding of statutory damages of up to \$250,000 (17 USC 504) for infringement, and may result in further civil and criminal penalties. All rights reserved.

TABLE OF CONTENTS

1. PURPOSE..... 2
1.1 Discussion..... 2
1.2 Applicability 2
2. PREREQUISITES 2
2.1 Special Items Required..... 2
3. PRECAUTIONS..... 2
4. INSTALLATION INSTRUCTIONS 3
4.1 Installing the MC521 Controller..... 3
5. WIRING INSTRUCTIONS 3
5.1 Evaluating Power Requirements..... 3
5.2 Connecting Main Power Wiring..... 3
5.3 Connecting Accessories (As Applicable) 3
6. TUNE-IN INSTRUCTIONS 4
6.1 Tuning In the MC521 Controller Using the Palm Pilot..... 5
6.2 Tuning In the MC521 Controller Using the Controller Pushbuttons..... 8
6.3 Final Tune-In Adjustments 11
6.4 Spare Parts List..... 12

Attachments

Attachment 1, MC521 Controller Controls and Indicators 13
Attachment 2, MC521 System Wiring Diagram..... 15
Attachment 3, MC521 Terminal Block Connections —TB1 Through TB5..... 19
Attachment 4, ANSI/BHMA and UL Compliance Requirements for Sliding Doors.....20
Attachment 5, Palm Troubleshooting Aid.....22
Attachment 6, Palm Troubleshooting Screen Descriptions.....24

1. PURPOSE

1.1 **Discussion**

This manual provides installation instructions, wiring instructions, and tune-in instructions for the MC521 Controller.

On Dura-Glide sliding doors, the MC521 Controller replaces both the microprocessor control box and the interface board. The door activation devices (SU-100 motion sensors, carpets, push plates, etc.), lock, function switch, doorway holding beams, and door position switches previously connected to the interface board must be connected to the MC521 Controller.

Attachment 1 illustrates the MC521 controller controls and indicators. Attachment 2 illustrates system wiring for Dura-Glide series sliders.

1.2 **Applicability**

This manual is applicable to the Dura-Glide series sliding doors. Instructions for connecting optional accessories are not provided in this manual.

2. PREREQUISITES

2.1 **Special Items Required**

- Stanley Access Technologies document No. 203975, “Stan Vision Installation and Operation” (if installed)
- Stanley Access Technologies document No. 203957, “SU-100 Motion Sensor Installation and Operation” (if installed)
- SU-100 tune-in remote control (if SU-100 Motion Sensor is installed)
- Stanley Access Technologies document No. 203768, “Stanguard™ Threshold Sensor Installation and Operation” (if installed)
- Optex OA-203C manufacturer’s installation and tune-in instructions (if installed)
- Palm Programming kit No. 713861 (available from factory) or one of the following compatible Palm models: M125, 130, 500, 505, 515, Zire 71, Tugsten C, TX, W, T, T2, LifeDrive, and Treo 650, 700p.
- Degreaser
- Instructions for any other device to be wired into the MC521 controller.

3. PRECAUTIONS

3.1 **All ANSI/BHMA and UL Requirements in Attachment 4 must be met before the door is put into operation.**

4. INSTALLATION INSTRUCTIONS

4.1 **Installing the MC521 Controller**

NOTE

This manual covers new door installations in which the MC521 is factory-installed and wired.

5. WIRING INSTRUCTIONS

5.1 **Evaluating Power Requirements**

5.1.1 EVALUATE door system power requirements as follows:

- ENSURE power source is a dedicated 115 VAC, 50/60 Hz source with 20A circuit rating. If four operators are used, the source should have a 30A rating.
- ENSURE *no more than* four operators will be connected to one circuit.
- ENSURE power source is *not* shared with other equipment, i.e., cash registers, EAS systems, or other electromagnetic interference generators.

5.2 **Connecting Main Power Wiring**

WARNING

1. To prevent injury to personnel, incoming electrical power to the header must be deenergized before connecting electrical service to the control box.
2. All electrical wiring must conform to National Electrical Code Requirements.

5.2.1 DEENERGIZE incoming electrical power to header.

5.2.2 Refer to Attachment 2, and, using wire nuts, CONNECT incoming line, neutral, and ground wires to the controller power harness.

5.2.3 IF adhesive wire clamps will be used, DEGREASE metal surfaces on inside of header cover where clamps will mount.

5.2.4 SECURE wiring to top of the header track tube, and ENSURE the following:

- All wires are clear of belts and belt brackets.
- Header cover opens and closes without interference.

5.3 **Connecting Accessories (As Applicable)**

5.3.1 Refer to Attachments 2 and 3, and CONNECT any of the following subsystems to the MC521 controller:

- Function switch (rotary, rocker and “POWER” switch wiring)
- Stanguard threshold sensor
- Doorway holding beam
- Cycle counter
- Breakout switch
- Solenoid lock

- SU-100 motion sensor(s) wiring (refer to Stanley Document #203957)
- OA-203C presence sensor(s) wiring
- Push plate wiring
- Door position switch closed contact (with door closed)
- Stanvision

6. TUNE-IN INSTRUCTIONS

WARNING

The door path must be free of objects and remain clear until the First Install Sequence (FIS) is complete. During this sequence the sensors are inactive and the door has no SAFETY. To stop the door, turn power off or put the doors into breakout.

NOTE

1. The MC521 Controller can be tuned-in using a PDA or using the pushbutton switches located on the controller. Tune-in using the PDA is the preferred method.
2. During normal operation, the digital display indicates status codes. The “UP” and “DOWN” pushbutton switches can be used to enter and display data values. The user interface values are shown in Tables 2 through 4.
3. If a solenoid lock is installed with no lock circuit board, set Lock Logic to the actual lock type (Fail Safe or Fail Secure). If a Fail Safe or Fail Secure Lock is being installed with a lock circuit board, the Lock Logic must be set to Fail Secure.
4. **Handing:** Manually open door noting rotation of belt pulleys. If counter clockwise (CCW) use right hand during FIS. If clockwise (CW) use left hand during FIS. See figure below.
5. The first installation sequence (FIS) is used to perform the initial configuration. Upon completion of FIS, all setup parameters are stored in non-volatile memory. Subsequent power cycles will reload the configuration parameters that were configured during FIS.
6. Decimal points on digital display are encoder 1 signals.
7. After changing values, the values must be saved in EEPROM.

HANDING

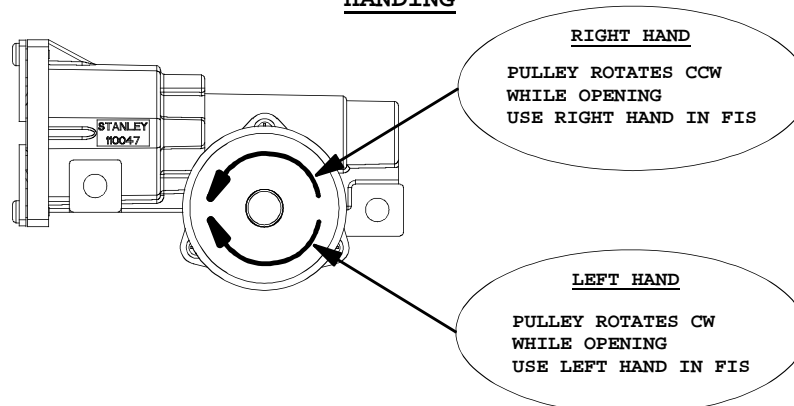

6.1 Tuning In the MC521 Controller Using the Palm Pilot

NOTE

The following steps provide instructions for tuning the MC521 controller using the Palm Pilot. MC521 application software is required. Connect Palm to MC521 controller, turn on header POWER switch, and perform the following steps.

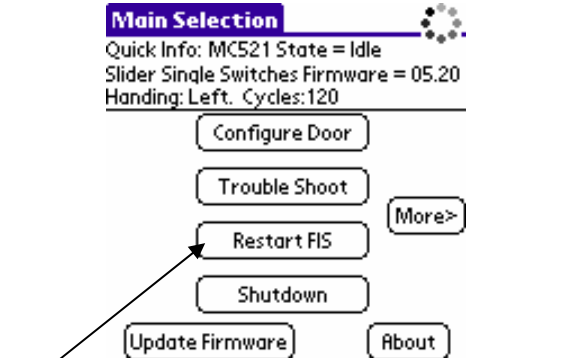
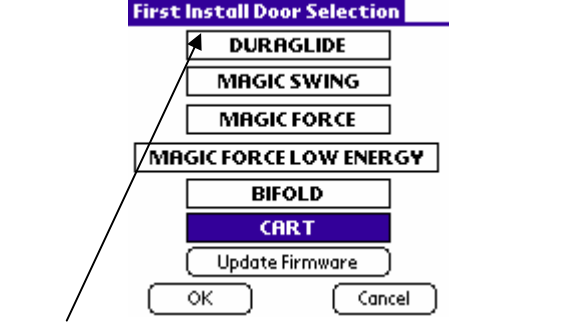
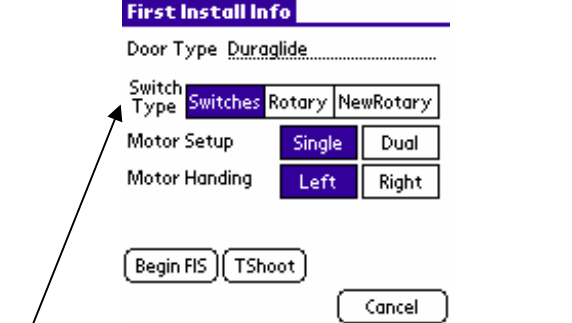
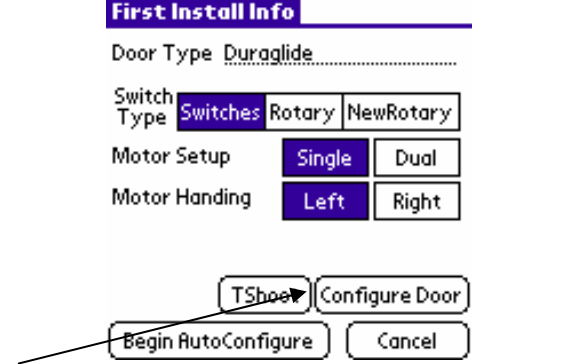
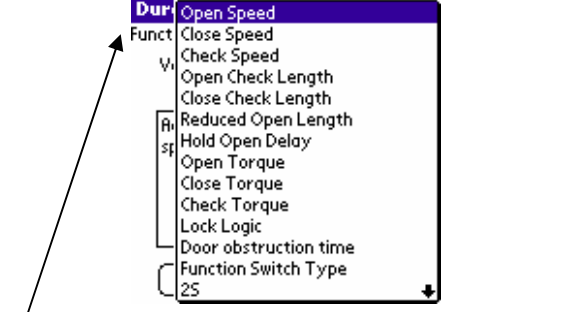
 <p>Step 1: Select MC521 Tool Box from the list of applications.</p>	 <p>Step 2: Select Restart FIS on the Main selection menu. (FIS = First Install Sequence) Note: Firmware is the software revision. Cycles are door cycles in memory and are only accurate on revision C (5.19) and higher.</p>
 <p>Step 3: Select Duraglide.</p>	 <p>Step 4: Select applicable Switch Type, Motor Setup, and Motor Handing.</p>
 <p>Step 5: If additional configuration is needed press Configure Door.</p>	 <p>Step 6: Configure additional settings and press Update after each setting has been changed. Once completed, press Cancel to go back to the Main selection menu.</p>

First Install Info

Door Type Duraglide

Switch Type **Switches** Rotary NewRotary

Motor Setup **Single** Dual

Motor Handling **Left** Right

TShoot Configure Door

Begin AutoConfigure Cancel

Step 7: Press **Begin AutoConfigure**

Warning !!! WARNING !!!

The door path must be free of objects and remain free until complete.

Press OK to continue when ready.

OK Cancel

Step 8: Press **OK**.

FIS in progress

Put function switch to Hold Open to begin auto configure sequence.

Operate Cancel

Step 9: Put door function switch to **Hold Open** then immediately back to **Closed**. The same function can be done remotely from the Palm by pressing **Operate**.

Operate Motor 1 or Motor 2

Warning: Using this can cause the door to operate and move.

Use Cancel to exit.

Motor 1 or Motor 2 sends the command to operate the respective motor.

Cancel **Motor 1** Motor 2

Step 10: For all doors *except* cart doors press **Motor 1** to operate and have door(s) move. For cart doors, press **Motor 2** when configuring the second door.

WARNING: During this sequence the sensors are inactive and the door has no SAFETY. To stop the door, turn power off or put the doors into breakout.

Step 11: Door will go through a learn sequence to configure itself. The door will perform the following operations in learn mode:

- Open fully at check speed.
- Close fully at check speed.
- Open at full speed halfway and stop.
- Open fully in check speed.
- Close at close speed halfway and stop.
- Finish closing at check speed.

Main Selection

Quick Info: MCS21 State = Idle
Slider Single Switches Firmware = 05.20
Handing: Left. Cycles:120

Configure Door

Trouble Shoot More>

Restart FIS

Shutdown

Update Firmware About

Step 12: If the door is not operating correctly select **Trouble Shoot** to enter the Trouble Shooting menu.

Turbo	TB1	TB2	TB3	TB4	TB5
1					
2					
3					
4					
5					
6					
7					
8					
9					
10					

Operate Cancel

Step 13: View the I/O grid to verify the sensors and inputs. Dark indicates input/output contact is closed. Light indicates input/output contact is open. Gray never changes.

Main Selection

Quick Info: MC521 State = Idle
Slider Single Switches Firmware = 05.20
Handing: Left. Cycles:120

Configure Door

Trouble Shoot

Restart FIS

Shutdown

Update Firmware

About

More>

Step 14: Press **More>** to access more functions.

More tools

Quick Info: MC521 State = Idle
Slider Single Switches Firmware = 05.20
Handing: Left. Cycles:121

Clone Settings

Summary Listing

Cancel

Step 15: Press **Clone Settings** to pull all of the settings out of one controller and put them into another door.

Copy Door Settings

Quick Info: MC521 State = Idle
Slider Single Switches Firmware = 05.20
Handing: Left. Cycles:122

Fetch Settings

Status: Ready to fetch settings.....

Cancel

Step 16: To pull all of the settings out of one controller and put them into another door, press **Fetch Settings**.

Notes: The Fetch Settings feature will only work if both doors are the same and both doors have the same software version. FIS must be performed on controllers before Push Settings can be used.

Copy Door Settings

Quick Info: MC521 State = Idle
Slider Single Switches Firmware = 05.20
Handing: Left. Cycles:122

Fetch Settings

Push Settings

Status: Ready to push settings.....

Cancel

To put the settings into another controller, plug the Palm into the other controller and press **Push Settings**.

Note: The Push Settings feature will only work if both doors are the same and both doors have the same software version.

More tools

Quick Info: MC521 State = Idle
Slider Single Switches Firmware = 05.20
Handing: Left. Cycles:121

Clone Settings

Summary Listing

Cancel

Step 17: Press **Summary Listing** to view all current settings.

<p>Summary </p> <p>Quick Info: MC521 State = Idle Slider Single Switches Firmware = 05.20 Handing: Left. Cycles:122</p> <hr/> <table> <thead> <tr> <th>Setting</th> <th>Value</th> </tr> </thead> <tbody> <tr> <td>Open Speed</td> <td>30</td> </tr> <tr> <td>Close Speed</td> <td>10</td> </tr> <tr> <td>Check Speed</td> <td>4</td> </tr> <tr> <td>Open Check Length</td> <td>11</td> </tr> <tr> <td>Close Check Length</td> <td>5</td> </tr> <tr> <td>Reduced Open Length</td> <td>50</td> </tr> <tr> <td>Hold Open Delay</td> <td>10</td> </tr> <tr> <td>Open Torque</td> <td>32</td> </tr> </tbody> </table> <p><input type="button" value="Next"/> <input type="button" value="Cancel"/></p>		Setting	Value	Open Speed	30	Close Speed	10	Check Speed	4	Open Check Length	11	Close Check Length	5	Reduced Open Length	50	Hold Open Delay	10	Open Torque	32
Setting	Value																		
Open Speed	30																		
Close Speed	10																		
Check Speed	4																		
Open Check Length	11																		
Close Check Length	5																		
Reduced Open Length	50																		
Hold Open Delay	10																		
Open Torque	32																		
<p>Step 18: Review the information on the summary listing.</p>																			

6.2 Tuning In the MC521 Controller Using the Controller Pushbuttons

NOTE

1. To change the INDEX:
Hold ENTER switch while pressing UP or DOWN to get to desired INDEX
2. To change a VALUE:
Unlock the keypad by setting index 99 to value 01.
After the desired INDEX is selected, release ENTER and *within 2.5 seconds* press UP or DOWN to get the desired VALUE. (If the the UP or DOWN buttons are not pressed within 2.5 seconds of releasing the ENTER button, the display will change from the VALUE back to the STATUS.)
3. To display STATUS CODE:
A few seconds after the VALUE is selected, the display indicates the STATUS CODE
4. To show the INDEX and VALUE
To show the INDEX, hold ENTER. Once ENTER is released the display will show the VALUE of that INDEX.
5. Read the descriptions entirely before performing each step. Check the INDEX and VALUE after each step.
6. To store changes in permanent memory:
Cycling door open one time will store changes.
7. To lock keypad:
Lock keypad by setting index 99 to value 01 or by turning power OFF and then ON.
8. To access the door cycle counter function:
 - a. Ensure that the keypad is locked by setting index 99 to 01.
 - b. Ensure that the index is set to any index but 99.
 - c. Press the up or down key to access the door cycle counter.
 - d. The display will show “dc” followed by four pairs of digits, followed by “dc”. For example, if the door count was 12345678 cycles the controller will display “dc” “12” “34” “56” “78” “dc”.

Table 1. FIS Procedure using Pushbuttons

Step	Description	Display		
		Index	Value	Status Code
1	Set Function switch to “Closed.”			
2	Turn power on.			
3	Unlock keypad.	99	00	00
4	Restart FIS.	96	01	A0
5	Select door type: Slide, <u>01</u> single motor or <u>02</u> dual motor.	00	01 (single) 02 (dual)	A0
6	Select handing: <u>00</u> Right or <u>01</u> Left. Manually open door noting rotation of belt pulleys. If counterclockwise (CCW) use right hand during FIS. If clockwise (CW) use left hand during FIS.	01	00 (right) 01 (left)	A0
7	Accept FIS. As soon as the VALUE is changed to 01, display will go to 20 (Open Speed value) and then to A1. (Note: 20 is the default value.) When A1 is displayed go to next step.	03	01	A1
8	Make changes: Function switch <u>01</u> Rocker or <u>00</u> Rotary. The INDEX will start at 00.	11	01 rocker 00 rotary	A1
9	Select Lock Logic: Lock Logic, 00 = Fail Safe; 01 = Fail Secure. Note: For locks with circuit board, set to 01 Fail Secure. For locks with no circuit board, set to Fail Safe or Fail Secure.	07	00 Fail Safe 01 Fail Secure	
10	WARNING: During this sequence the sensors are inactive and the door has no SAFETY. To stop the door, turn power off or put the doors into breakout. Function switch: Switch to OPEN, momentarily, then CLOSED/LOCKED. Wait for the learn sequence to end. Display will show <u>A2</u> when finished.			A2
11	Lock keypad.	99	01	00
12	Final Tune in.			

Table 2. Index List

Index	Description
00-89	Settings Values, see Table 3.
90-95	Reserved.
96	Command – Restart FIS. Entering “01” will cause FIS to restart.
97	Firmware – Entering “01” will display “FE” followed by two pairs of digits followed by “FE”. For example, if the firmware was 0609 the controller will display “FE” “06” “09” “FE”.
98	Command – Restart auto configuration. Entering “01” will cause auto configuration.
99	Command – Lock. Entering “01” will lock all value inputs except this index. This prevents inadvertent changes to input values. Values may be unlocked by entering “00” in this index.

Table 3. Settings

Index	Min. Value	Max. Value	Description	Defaults	
				Single	Dual
00	05	35	Open speed, increment by 1.	20	20
01	05	12	Close speed, revolutions per second.	10	10
02	03	10	Check speed, revolutions per second.	04	04
03	00	99	Open check length, percent of full opening.	--	--
04	00	99	Close check length, percent of full opening.	--	--
05	00	99	Reduced open position, percent of full opening (00=full open, 99=full close).	--	--
06	01	99	Hold open delay (0 to 25 sec.).	03	03
07	00	01	Lock Logic, 01 = Fail Secure, 00 = Fail Safe Note: For locks with circuit board, set to 01 Fail Secure. For locks with no circuit board, set to Fail Safe or Fail Secure.	01	01
08	00	99	Open torque, percent of full scale.	33	33
09	00	99	Close torque, percent of full scale.	22	15
10	00	99	Check torque, percent of full scale.	24	15
11	00	02	Dura-Glide function switch type: 00=double pole rotary, 01=rocker, 02=single pole rotary (Single pole rotary not available until further notice).	01	01
12	00	01	2S Operation, 0=off, 1=on	00	00
13	01	99	Obstruction Time Delay (.01 – 2.55 sec) Heavy and dual motor doors may require a longer obstruction time (45 on buttons or 1.0 sec. on Palm).	30	100
14	00	60	*Open Acceleration, (larger value=faster acceleration).	07	07
15	00	60	*Open Braking, (larger value=increased braking).	08	08
16	00	60	*Close Acceleration, (larger value=faster acceleration).	04	04
17	00	60	*Close Braking, (larger value=increased braking).	02	02
18	00	02	00 = Off (Delay Egress) 01 = 15 sec. delay 02 = 30 sec delay	00	00

* These parameters are only available on software revision C (5.19) and higher.
Note: Door must be cycled open for changes to be stored in permanent memory.

Table 4. Status Codes

Status Code	Description
00	Normal operation—All OK.
20	Breakout.
A0	First installation sequence (FIS).
A1	Auto-configuration sequence.
A2	Auto-configuration confirmation sequence.
A9	Invalid Door Type selected. Switch Power OFF and then ON and Restart FIS
b0	Invalid mode.
b1	Encoder error.
dc	Display door cycle counter
EE	Obstruction in Learn Mode
0b	Obstruction after Learn Mode
dE	Delayed Egress

6.3 Final Tune-In Adjustments

- 6.3.1 Refer to ANSI A156.10, "American National Standard for Power Operated Doors," and Attachment 4 and DETERMINE ANSI and UL door operating requirements.
- 6.3.2 IF Stanguard threshold sensor is installed, refer to Stanley Access Technologies document No. 203768, "Stanguard™ Threshold Sensor Installation and Operation," and TUNE-IN Stanguard threshold sensor.
- 6.3.3 IF SU-100 motion sensor(s) are installed, refer to Stanley Access Technologies document No. 203957, "SU-100 Motion Sensor Installation and Operation," and TUNE-IN SU-100 motion sensor(s).
- 6.3.4 IF OA-203C presence sensor(s) are installed, refer to manufacturer's instructions and TUNE-IN OA-203C presence sensor(s).
- 6.3.5 To ensure that all settings have been stored in EEPROM memory, turn power OFF and then back ON. Repeat step 5.3.1.

6.4 Spare Parts List

Description	Part Number
MC521 Controller, includes 3 terminal blocks	313969
MC521 Controller Manual	204003
Harness, Rocker Switch to Control Box, 98 inches	414098
Harness, Rocker Switch to Control Box, 180 inches	414099
Harness, Holding Beam to Control Box, 24 inches	414106
Harness, Rotary Switch to Control Box, 180 inches	414107 - 1
Harness, Rotary Switch to Control Box, 480 inches	414107 - 2
Harness, Holdbeam/Breakout, 48 inches	414111
Harness, Power, 18 inches	415000
Harness, Encoder Cable Adapter, 12 inches	415001
Harness, Solenoid Lock, 67 inches (See Note)	516922-1
Harness, Solenoid Lock, 124 inches (See Note)	516922-2
Harness, Solenoid Lock Pigtail	516921
Power Supply 24VDC	516871
Terminal Block Plug, 10 position	714055
Palm Cable, Black (For M Series, I705, Zire 71, Tungsten C, T2, T3, W)	415044
Palm Cable, Yellow (For Tungsten E2 and X, Treo 650, Life Drive)	516864
Harness, motor, 14 feet	413362
Harness, motor, 17 feet	413362-1
Harness, line connect, 6 feet	412544
Harness, line connect, 10 feet	412545
Harness, Rocker Switch to Control Box, 252 inches	414126
Harness, Solenoid Lock Power Signal, 264 inches	516823-4
Harness Motor Extension, 42 inches	411746
Counter, External Accessory	413787
MC521 Palm Extension Retro Kit, 6 feet	313995
MC521 Palm Extension Retro Kit, 40 feet	313996
Harness, Encoder Adapter Stanvision	415078
Harness, Encoder Extension 40 inches	415079
NOTE: When replacing a solenoid lock harness, solenoid lock pigtail harness 516921 is required for solenoid locks that do not have a pigtail.	

Attachment 1

MC521 Controller Controls and Indicators

(Sheet 1 of 2)

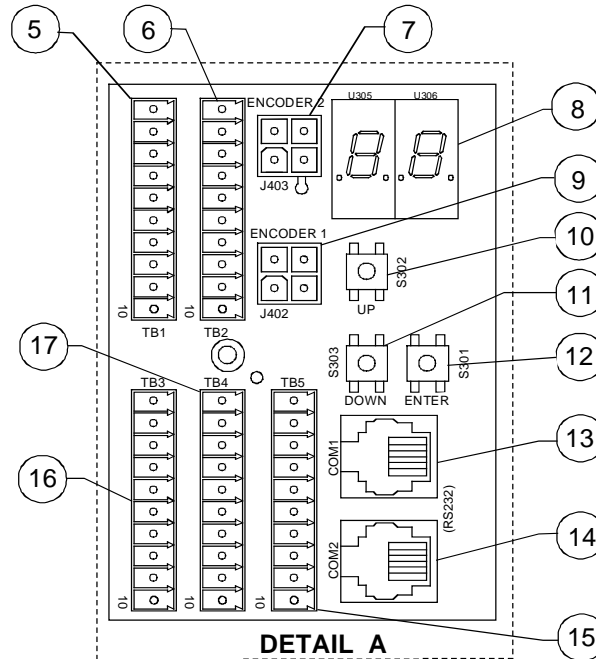
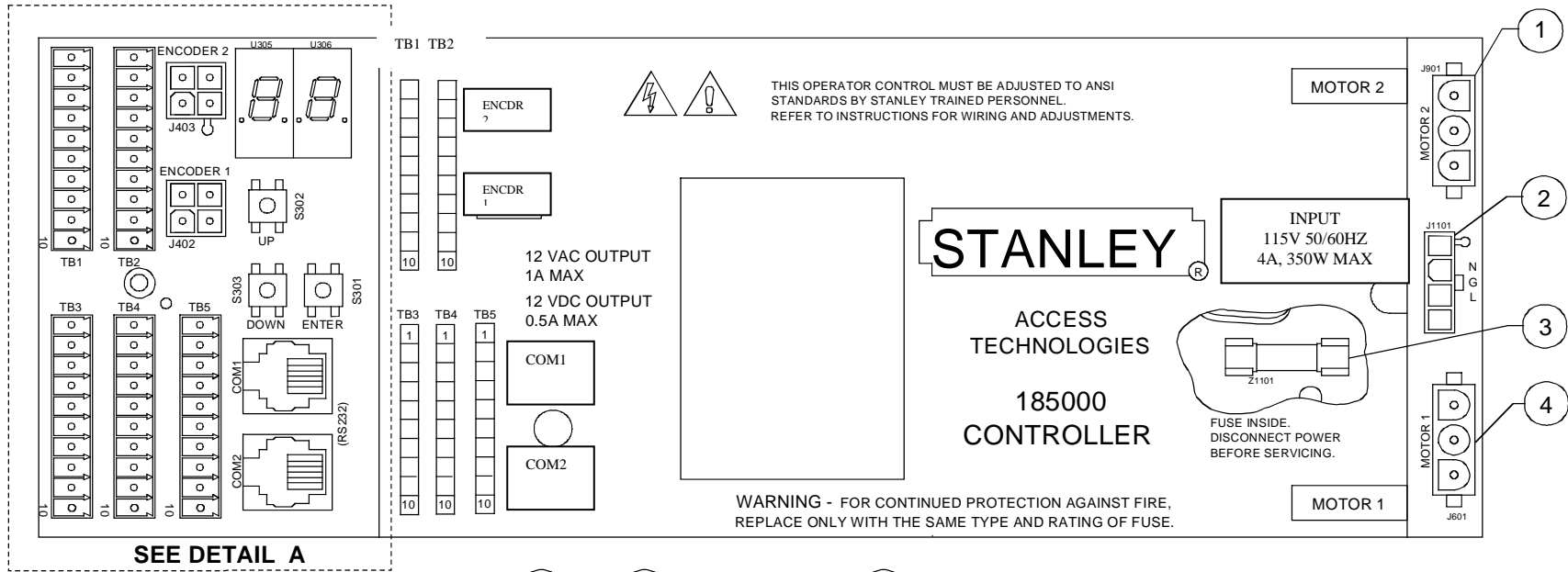

204003

Rev. D, 3/11/07

Page 13 of 24

© 2007, THE STANLEY WORKS. ALL RIGHTS RESERVED.

UC001A

Attachment 1
MC521 Controller Controls and Indicators
(Sheet 2 of 2)

ITEM	CONTROL/ INDICATOR	DESCRIPTION
1	Motor 2 Connector J109	Motor No. 2 connector.
2	Power Connector J1101	Connection point for incoming line, neutral, and common power wiring.
3	Fuse Z1101	Controller fuse-- 5 Amp, 250V
4	Motor 1 Connector J601	Motor No. 1 connector.
5	Terminal Block Connector TB1	Connection point for door cycle counter and solenoid lock control.
6	Terminal Block Connector TB2	Connection point for function switch (rotary or rocker).
7	Encoder 2 Connector J403	Not Used
8	Two Digit Display	Displays Controller Status. Also serves as the display for tune-in by pushbutton switches and indicates encoder movement.
9	Encoder 1 Connector J402	Connection point for motor encoder No. 1.
10	Up Pushbutton Switch S302	Used manual setup and tuning of door when PDA is not available.
11	Down Pushbutton Switch S303	Used for manual setup and tuning of door when PDA is not available.
12	Enter Pushbutton Switch S301	Used for manual setup and tuning of door when PDA is not available.
13	COM1 Jack	RS232 COM1 connector. Connection point for PDA harness.
14	COM2 Jack	RS232 COM2 connector. Future provision.
15	Terminal Block Connector TB5	Connection point for side-screen sensor and closed position switch.
16	Terminal Block Connector TB3	Connection point for Stanguard, doorway holding beam, and breakout switch. Using jumper wires across TB3 terminals 1 to 5 and 2 to 6, internal transformer supplies power to multiple external sensors.
17	Terminal Block Connector TB4	Connection point for inside sensor, outside sensor and push plate.

Attachment 2

MC521 System Wiring Diagram

(Sheet 2 of 4)

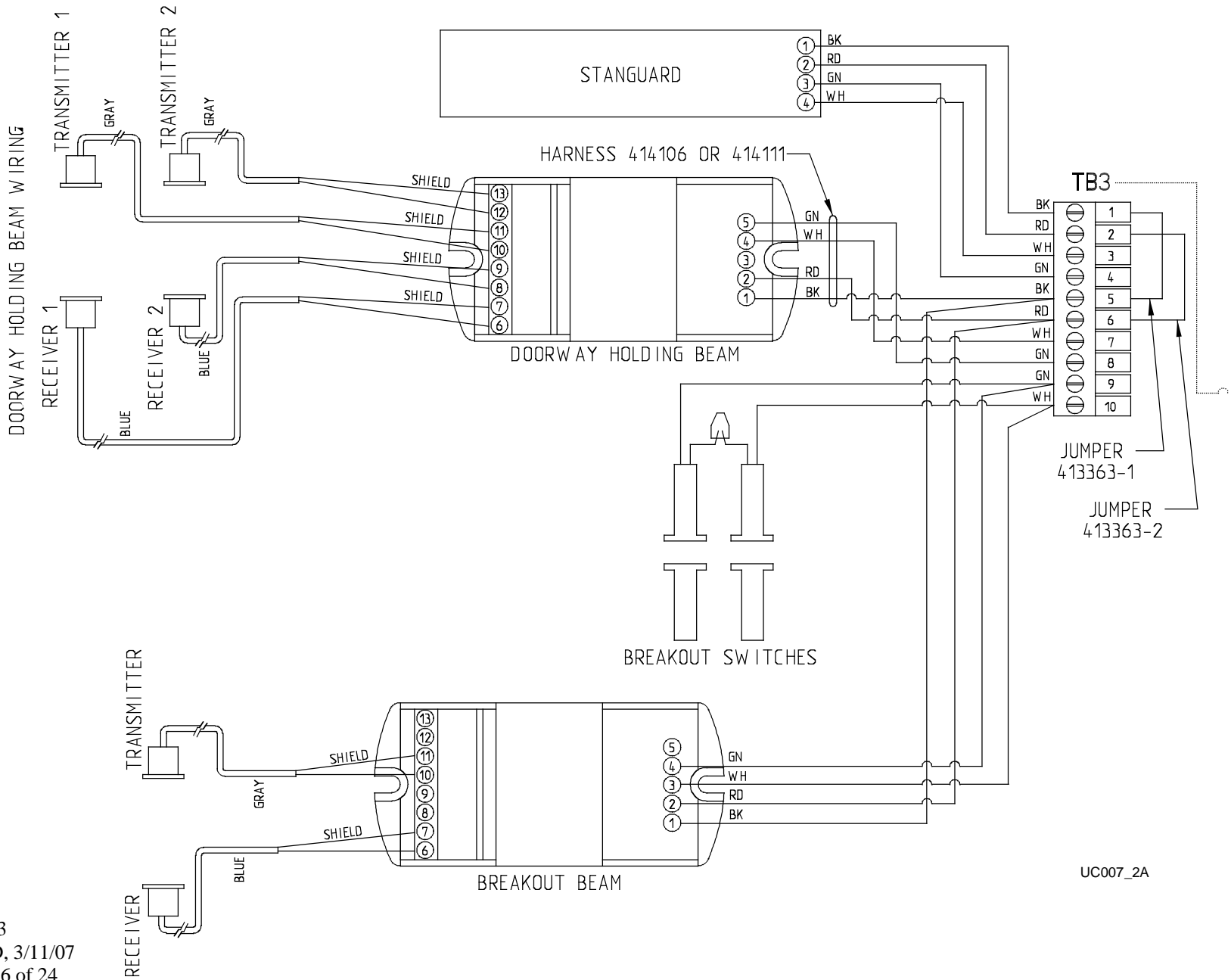

UC007_2A

Attachment 2

MC521 System Wiring Diagram

(Sheet 3 of 4)

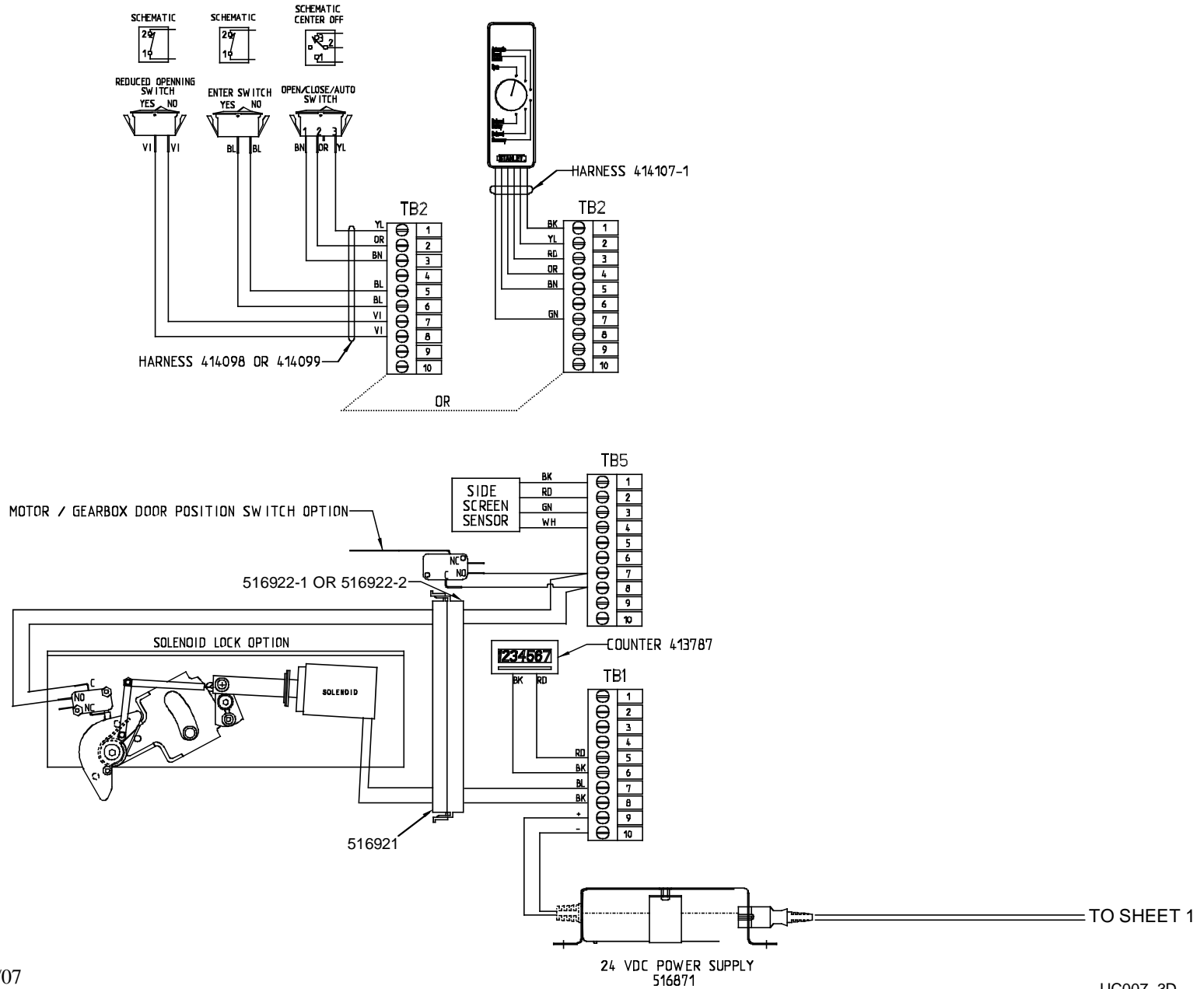

Attachment 2

MC521 System Wiring Diagram

(Sheet 4 of 4)

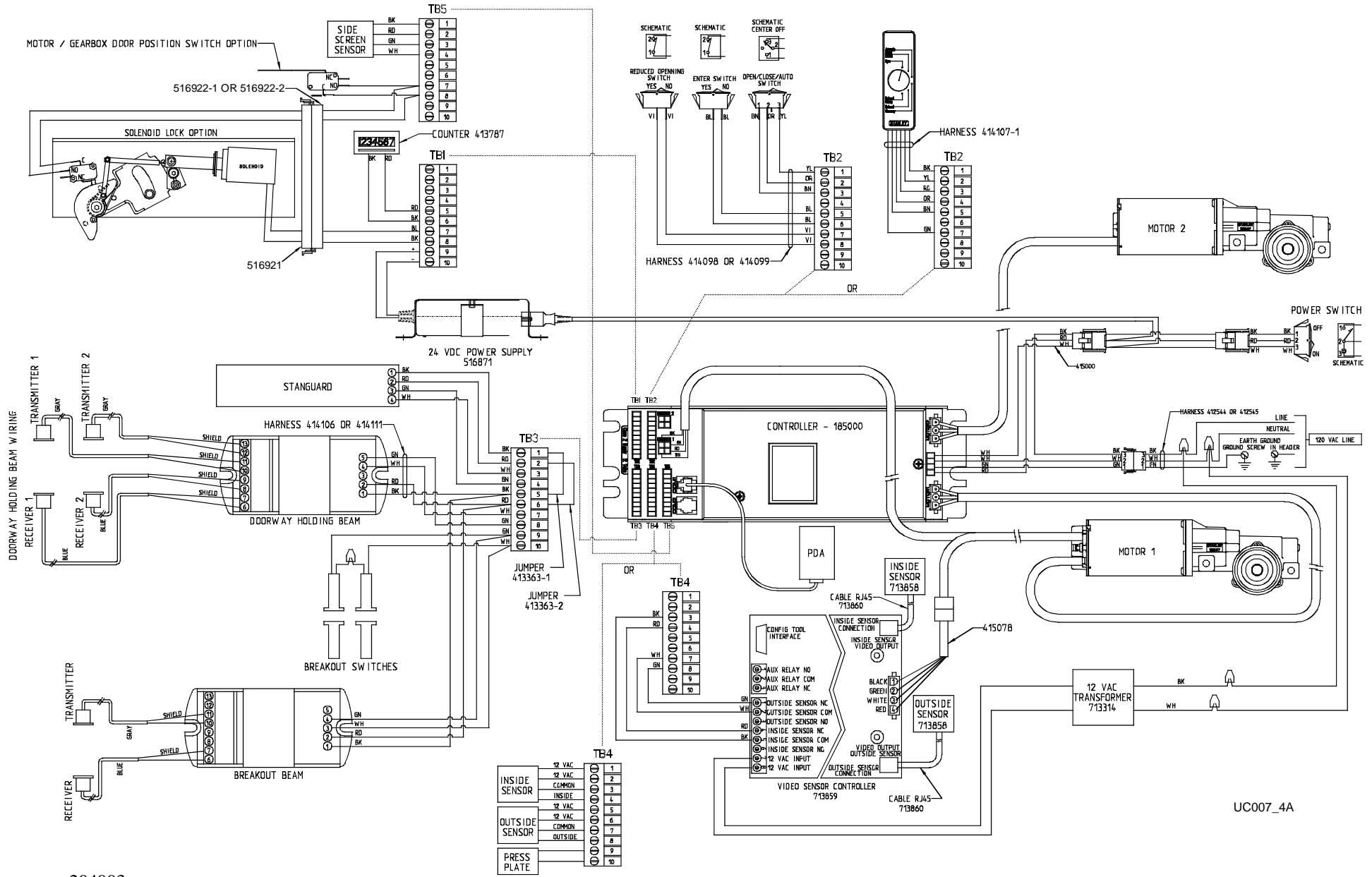

204003

Rev. D, 3/11/07

Page 18 of 24

© 2007, THE STANLEY WORKS. ALL RIGHTS RESERVED.

Attachment 3

MC521 Terminal Block Connections —TB1 through TB5

(Sheet 1 of 1)

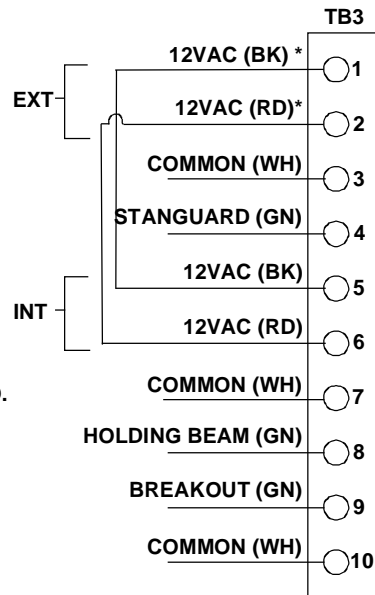
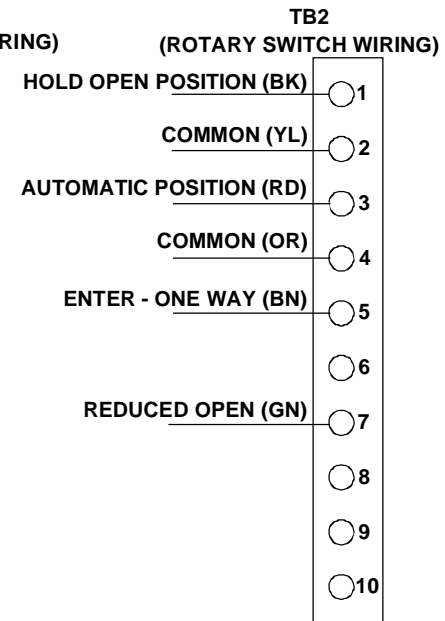
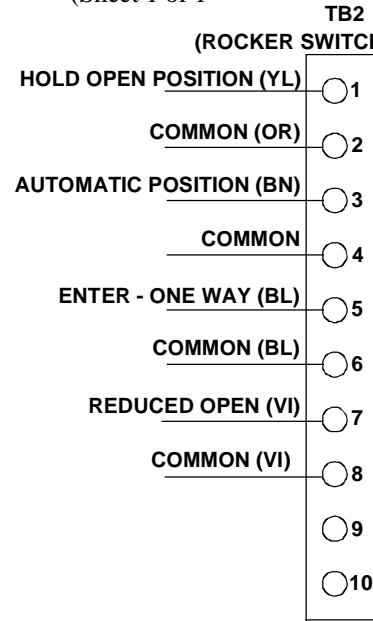
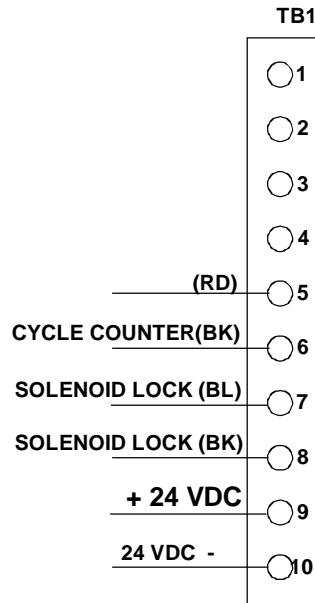

* REMOVE IF EXTERNAL POWER SUPPLY IS USED.

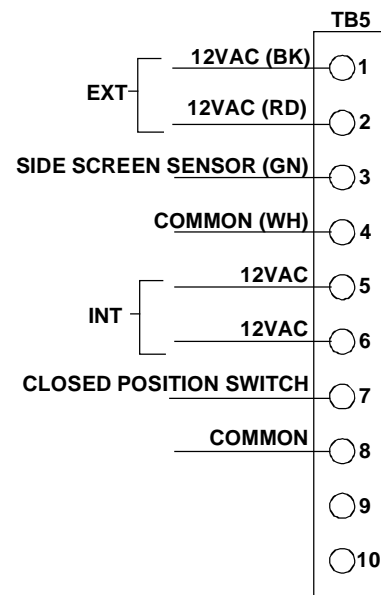
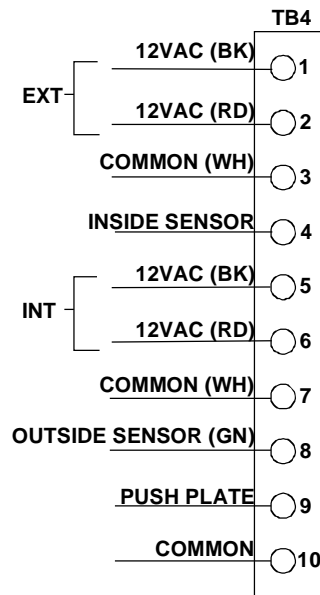

Attachment 4
ANSI/BHMA and UL Compliance Requirements for Sliding Doors
(Sheet 1 of 2)

Final adjustment and proper operation of the door system must be and shall be performed in the field.

Note: These instructions are for informational purposes and do not substitute for review against the current revision of the referenced standards. Where a requirement exists in multiple standards, such as the ANSI/BHMA standard and the UL standard, the more restrictive condition applies. Other local codes and fire codes likely exist, and must also be followed.

1.0 ANSI/BHMA A156.10 Sliding Door Systems

Sliding door systems must be installed and adjusted for compliance with the current version of ANSI/BHMA A156.10, “American National Standard for Power Operated Pedestrian Doors”.

Critical aspects of the installation for compliance with A156.10 include:

- Control mat size, layout, molding height, active areas and sensitivity.
- Sensor pattern size, sensitivity, and function.
- Knowing Act guidelines and secondary activating zone.
- Entrapment protection rules including door speeds, forces, and time delays.
- Signage. (Decals and application instructions are provided with the door system.)

2.0 UL 325 Compliance

All power operated door systems must be installed in compliance with the current edition of UL 325, “Standard for Safety for Door, Drapery, Gate, Louver, and Window Operators and Systems”.

2.1 Wiring

- 2.1.1 To reduce the risk of electric shock proper and reliable grounding is mandatory. See **Main Power Wiring** instructions and **Wiring Diagrams** in this guide for grounding techniques.
- 2.1.2 Permanent wiring is to be employed as required by the National Electrical Code and/or local codes.
- 2.1.3 Connection of external devices is shown in the wiring diagrams and terminal block layouts elsewhere in this guide. Refer to these figures for proper wiring of external devices to ensure compliance with UL 325.

2.2 Knowing Act

Doors activated by a manual switch (Knowing Act switch in ANSI/BHMA terms) must have the switch installed in a location from which operation of the door can be observed by the person operating the switch.

Attachment 4
ANSI/BHMA and UL Compliance Requirements for Sliding Doors
(Sheet 2 of 2)

- 2.3 To ensure that a sliding door operates in accordance with UL 325 entrapment protection criteria the following must be established:
- Manual opening force (sliding doors without breakout) or breakout force with power on or off must be less than 50 lbf (222.4 N).
 - Closing force must be less than 30 lbf (133.4 N).
 - A closing sliding door must not develop kinetic energy in excess of 7 ft-lbf (9.49 J). This is achieved by proper setting of the closing speed. See section entitled "Closing Speed".
 - Maximum recommended door weight:
 - Dura-Glide 5000 Series = 150 lbs (70 kg) per panel.
 - Dura-Glide/Dura-Guard/Dura-Storm and similar 2000/3000 Series = 220 lbs (100 kg) per panel.
 - IS10000/Double Diamond and similar Industrial Series = 300 lbs (90 kg) per panel

2.4 Closing Speed

Closing speed is measured over a travel distance of 2 or 3 feet. On smaller bi-part doors there may only be 2 feet of movement before the door system enters close-check (latch check). The time measurement should start once the door has achieved closing speed, usually 6 inches from full open. Mark this point on the floor with tape or other object. Measure from this point 2 or 3 feet toward the closed position and mark the next point. Use a stopwatch to measure the time it takes for the sliding panel to travel this distance during normal closing cycles. Make sure the door system is not braking or entering close-check during the measurement. Repeat the measurement 3 times and use the average value. The allowed time for a sliding panel to cover this distance during the closing cycle is given in the table below.

Door Weight (pounds)	Closing speed (seconds) 2 foot measurement	Closing time (seconds) 3 foot measurement
160 or less	2.0	3.0
161 to 180	2.1	3.2
181 to 200	2.2	3.3
201 to 220	2.3	3.5
221 to 240	2.4	3.7
241 to 260	2.5	3.8
261 to 280	2.6	4.0
281 to 300	2.7	4.1

Attachment 5
Palm Troubleshooting Aid

(Sheet 1 of 2)

Terminal & Pin	Description	State
TB1-5	External Cycle Counter Output	Dark = low (counter increments)
TB1-8	Solenoid Lock Output	Dark = unlocked
	w/o PCB, fail secure	Dark = unlocked
	w/o PCB, fail safe	Dark = locked

Rotary Function Switch States for TB2

	Hold Open	Closed/ Locked	Automatic	Oneway	Reduced	Reduced/ Oneway
TB2-1						
TB2-3						
TB2-5					Don't care	Don't care
TB2-7						

Rocker Function Switch States for TB2

	Hold Open	Closed/ Locked	Automatic	Oneway	Reduced	Reduced/ Oneway
TB2-1						
TB2-3						
TB2-5	Don't care	Don't care				
TB2-7	Don't care	Don't care				

Attachment 5
Palm Troubleshooting Aid
(Sheet 2 of 2)

Terminal & Pin	Description	State
TB3-4	Stanguard Input/Output	Dark = triggered or detecting
TB3-8 & TB4-8	Holding Beam Input & Outside Sensor (connected internally)	Dark = detecting
TB3-9	Breakout Input	Dark = no breakout
TB4-4 & TB4-9	Inside Sensor Input & Push Plate Input (connected internally)	Dark = detecting
TB4-8 & TB3-8	Outside Sensor & Holding Beam Input (connected internally)	Dark = detecting
TB4-9 & TB4-4	Push Plate Input & Inside Sensor Input (connected internally)	Dark = detecting
TB5-3	Side Screen Sensor Input	Dark = detecting
TB5-7	Closed-Door Position Switch Input	Dark = closed
TB5-10	Spare	

Attachment 6
Palm Troubleshooting Screen Descriptions
(Sheet 1 of 1)

T1P5 Swing/Slide = External Cycle Counter Output
T1P8 Swing = Bodyguard Data Line Output or Lock Output
Slide = Solenoid Lock Output
T2P1 Swing/Slide = Hold Open Function Switch Input
T2P3 Swing/Slide = Automatic Function Switch Input
T2P5 Slide = Enter/One Way Switch Input
T2P7 Slide = Reduced Open Switch Input
T2P9 Slide = Reduced Open/One Way Single Pole Rotary Input
T3P4 Swing = Stall Input
Slide/Bifold = Stanguard Input/Output
T3P8 Swing = Safety Input
Slide = Holding Beam Input
T3P9 Swing/Slide = Breakout Input
T4P4 Swing = Operate Sensor Input
Slide = Inside Sensor Input
T4P8 Swing = Safety Input
Slide = Outside Sensor Input
T4P9 Swing/Slide = Push Plate Input
T5P3 Swing = Sentrex Operate Sensor Input (Internal, From MicroBoard)
Slide = Side Screen Sensor Input
T5P7 Swing = Holding Beam Input
Slide = Closed-Door Position Switch Input
T5P10 Spare Output