

Stanley Access Technologies



MC521 Controller
Installation and Operation Manual

204003

Rev. C 2/3/05

Prohibition on Copying

Any unauthorized reproduction, disclosure or distribution of copies by any person of any portion of this work may be a violation of copyright law of the United States of America and other countries, could result in the awarding of statutory damages of up to \$250,000 (17 USC 504) for infringement, and may result in further civil and criminal penalties. All rights reserved.

TABLE OF CONTENTS

1. PURPOSE.....2
1.1 Discussion.....2
1.2 Applicability2
2. PREREQUISITES.....2
2.1 Special Items Required.....2
3. INSTALLATION INSTRUCTIONS3
3.1 Installing the MC521 Controller3
4. WIRING INSTRUCTIONS.....3
4.1 Evaluating Power Requirements3
4.2 Connecting Main Power Wiring.....3
4.3 Connecting Accessories (As Applicable)3
5. TUNE-IN INSTRUCTIONS.....4
5.1 Tuning In the MC521 Controller Using the Palm Pilot.....5
5.2 Tuning In the MC521 Controller Using the Controller Pushbuttons.....8
5.3 Final Tune-In Adjustments10
5.4 Spare Parts List11

Attachments

Attachment 1, MC521 Controller Controls and Indicators..... 12
Attachment 2, MC521 System Wiring Diagram..... 14
Attachment 3, MC521 Terminal Block Connections —TB1 Through TB5..... 17

1. PURPOSE

1.1 **Discussion**

This manual provides installation instructions, wiring instructions, and tune-in instructions for the MC521 Controller.

On Dura-Glide sliding doors, the MC521 Controller replaces both the microprocessor control box and the interface board. The door activation devices (SU-100 motion sensors, carpets, push plates, etc.), lock, function switch, doorway holding beams, and door position switches previously connected to the interface board must be connected to the MC521 Controller.

Attachment 1 illustrates the MC521 controller controls and indicators. Attachment 2 illustrates system wiring for Dura-Glide series sliders.

1.2 **Applicability**

This manual is applicable to the Dura-Glide series sliding doors. Instructions for connecting optional accessories are not provided in this manual.

2. PREREQUISITES

2.1 **Special Items Required**

- Stanley Access Technologies document No. 203975, “Stan Vision Installation and Operation” (if installed)
- Stanley Access Technologies document No. 203957, “SU-100 Motion Sensor Installation and Operation” (if installed)
- SU-100 tune-in remote control (if SU-100 Motion Sensor is installed)
- Stanley Access Technologies document No. 203768, “Stanguard™ Threshold Sensor Installation and Operation” (if installed)
- Optex OA-203C manufacturer’s installation and tune-in instructions (if installed)
- Palm Programming kit No. 713861
- Palm model M125, 130, 500, 505, 515, Zire 71, Tugsten C, W, T, T2, T3.
- Degreaser

3. INSTALLATION INSTRUCTIONS

3.1 **Installing the MC521 Controller**

NOTE

This manual covers new door installations in which the MC521 is preinstalled and wired.

4. WIRING INSTRUCTIONS

4.1 **Evaluating Power Requirements**

4.1.1 EVALUATE door system power requirements as follows:

- ENSURE power source is a dedicated 115 VAC, 50/60 Hz source with 20A circuit rating. If four operators are used, the source should have a 30A rating.
- ENSURE *no more than* four operators will be connected to one circuit.
- ENSURE power source is *not* shared with other equipment, i.e., cash registers, EAS systems, or other electromagnetic interference generators.

4.2 **Connecting Main Power Wiring**

WARNING

1. To prevent injury to personnel, incoming electrical power to the header must be deenergized before connecting electrical service to the control box.
2. All electrical wiring must conform to National Electrical Code Requirements.

4.2.1 DEENERGIZE incoming electrical power to header.

4.2.2 Refer to Attachment 2, and, using wire nuts, CONNECT incoming line, neutral, and ground wires to the controller power harness.

4.2.3 IF adhesive wire clamps will be used, DEGREASE metal surfaces on inside of header cover where clamps will mount.

4.2.4 SECURE wiring to top of the header track tube, and ENSURE the following:

- All wires are clear of belts and belt brackets.
- Header cover opens and closes without interference.

4.3 **Connecting Accessories (As Applicable)**

4.3.1 Refer to Attachments 2 and 3, and CONNECT any of the following subsystems to the MC521 controller:

- Door position switch (rotary, rocker and “POWER” switch wiring)
- Stanguard threshold sensor
- Doorway holding beam
- Cycle counter
- Breakout switch
- Solenoid lock

- SU-100 motion sensor(s) wiring (refer to Stanley Document #203957)
- OA-203C presence sensor(s) wiring
- Push plate wiring
- Door position switch closed contact (with door closed)
- Stanvision

5. TUNE-IN INSTRUCTIONS

WARNING

The door path must be free of objects and remain clear until the First Install Sequence (FIS) is complete. During this sequence the sensors are inactive and the door has no SAFETY. To stop the door, turn power off or put the doors into breakout.

NOTE

1. The MC521 Controller can be tuned-in using a PDA or using the pushbutton switches located on the controller. Tune-in using the PDA is the preferred method.
2. During normal operation, the digital display indicates status codes. The “UP” and “DOWN” pushbutton switches can be used to enter and display data values. The user interface values are shown in Tables 2 through 4.
3. If a Fail Safe or Fail Secure Lock is being installed the Lock Logic must be set to Fail Secure. The Fail Secure setting is the default and must not be changed at this time.
4. Handing: Manually open door noting rotation of belt pulleys. If counter clockwise (CCW) use right hand during FIS. If clockwise (CW) use left hand during FIS. See figure below.
5. The first installation sequence (FIS) is used to perform the initial configuration. Upon completion of FIS, all setup parameters are stored in non-volatile memory. Subsequent power cycles will reload the configuration parameters that were configured during FIS.
6. Decimal points on digital display are encoder 1 signals.
7. After changing values, the values must be saved in EEPROM.

HANDING

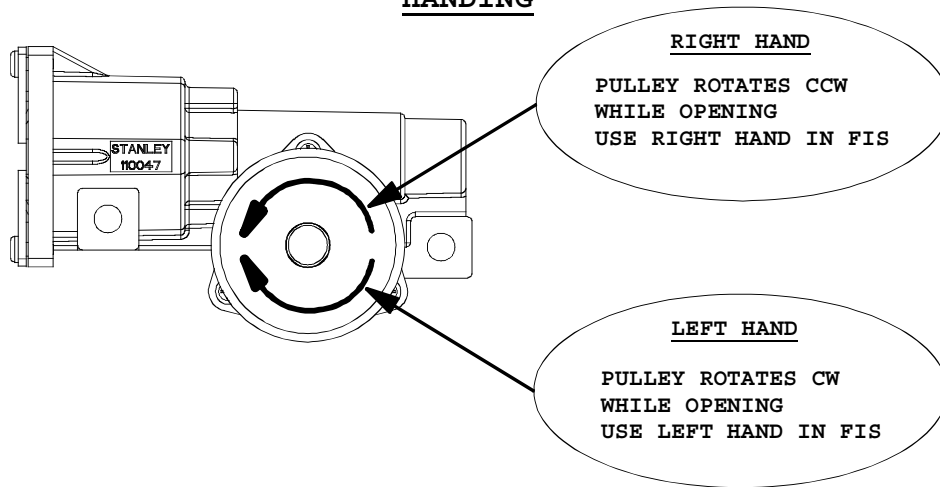

5.1 Tuning In the MC521 Controller Using the Palm Pilot

NOTE

The following steps provide instructions for tuning the MC521 controller using the Palm Pilot. MC521 application software is required. Connect Palm to MC521 controller and perform the following steps.

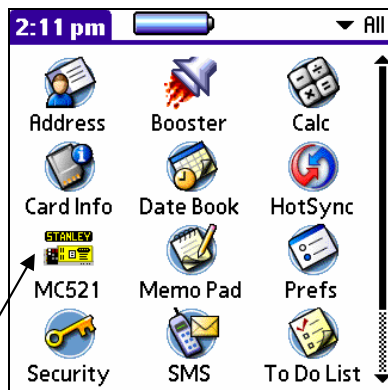

Step 1: Tap MC521 from the list of applications.

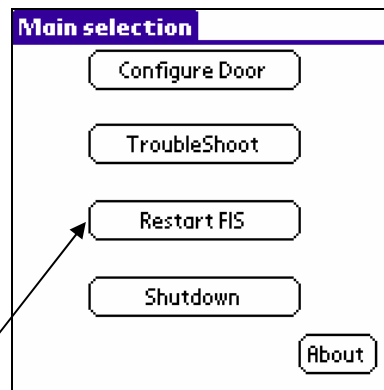

Step 2: Tap Restart FIS on the Main selection menu.

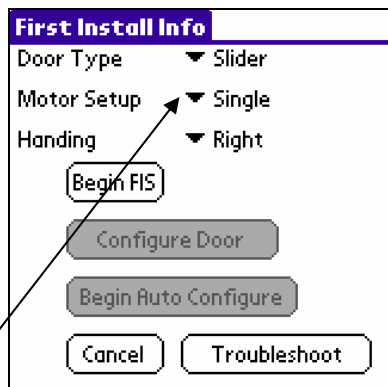

Step 3: To select values from list, tap on the down arrow to open list and select desired setting from list.

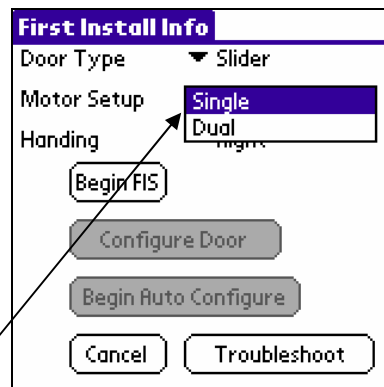

Step 4: Select motor setup by selecting the desired setting from list.

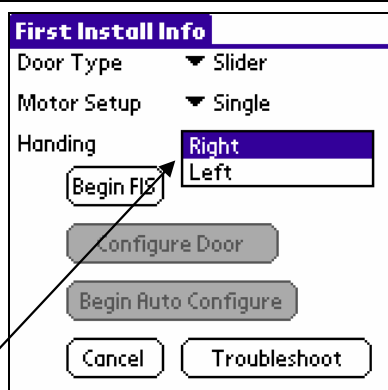

Step 5: Select the handing. Tap Begin FIS when finished. *See page 4 to determine handing.

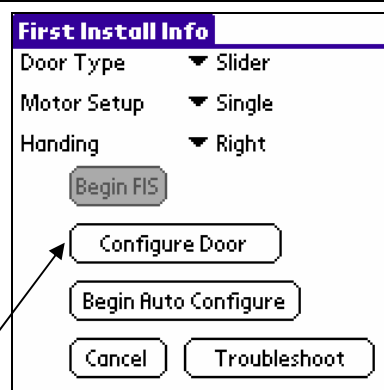

Step 6: Tap Configure Door.

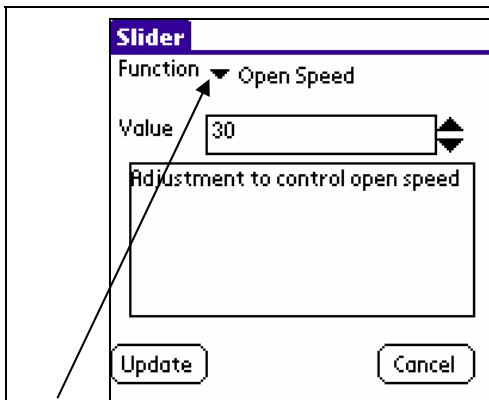

Step 7: Tap on down arrow to the right of **Function** to open drop down box.

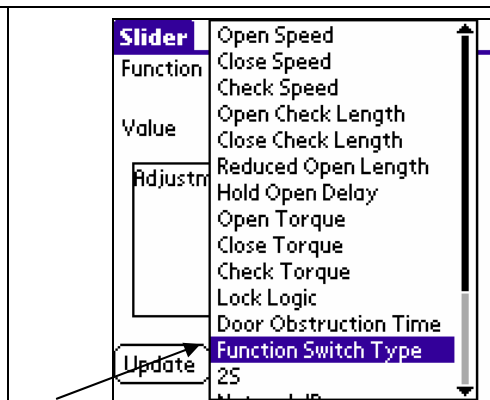

Step 8: Select **Function Type Switch** from list. This step **must** be done during setup.

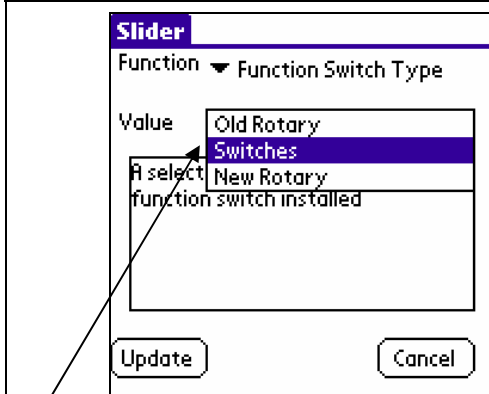

Step 9: Select the appropriate Switch Type from list in **Value** drop down box.

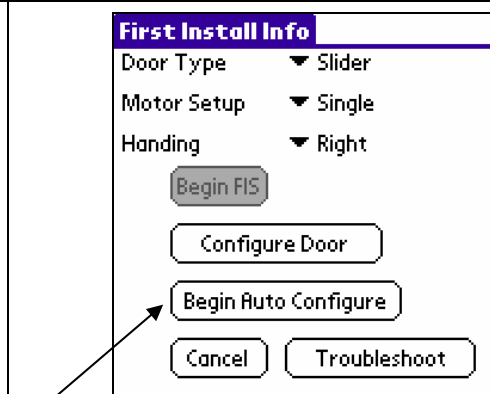

Step 10: Tap **Begin Auto Configure**.

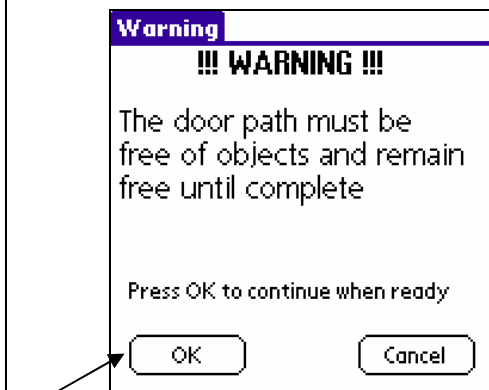

Step 11: Tap **OK**.

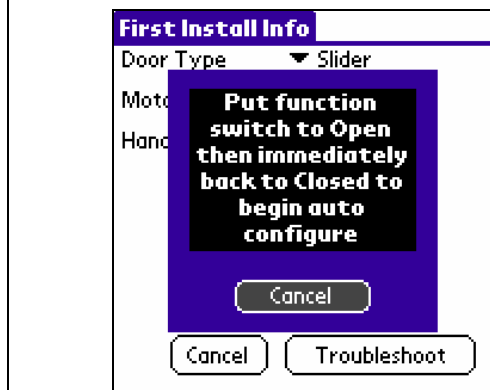

Step 12: Put door function switch to **Open** then immediately back to **Closed**.

WARNING: During this sequence the sensors are inactive and the door has no SAFETY. To stop the door, turn power off or put the doors into breakout.

Step 13: Door will go through a learn sequence to configure itself. The door will perform the following operations in learn mode:

- Open fully at check speed
- Close fully at check speed
- Open halfway at open speed and stop, finish opening at check speed
- Close halfway at close speed and stop, finish closing at check speed.

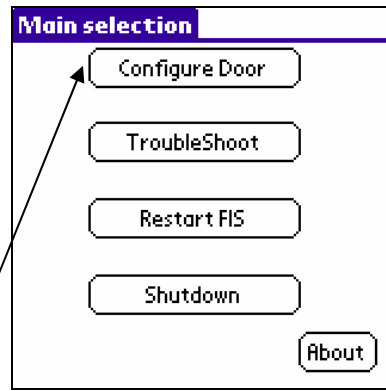

Step 14: If the door requires additional changes to be made to the settings, tap **Configure Door**.

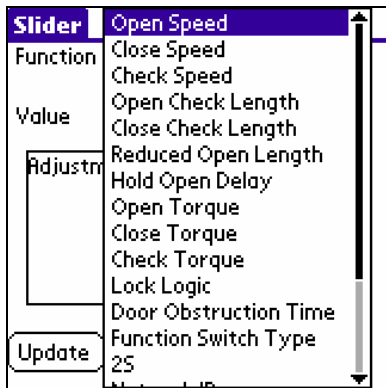

Step 15: Configure settings as needed and press **Update** after each setting has been changed. Once completed, press **Cancel** to go back to the Main selection menu.

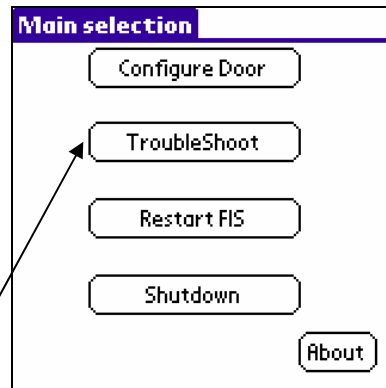

Step 16: If the door is not operating correctly tap **TroubleShoot** to enter the Trouble Shooting menu.



Step 17: View the recent status to verify that the door is operating normally. If more information is needed press **View I/O**.

Note: Firmware is the software revision. Cycles are door cycles in memory and are only accurate on revision C (5.19) and higher.

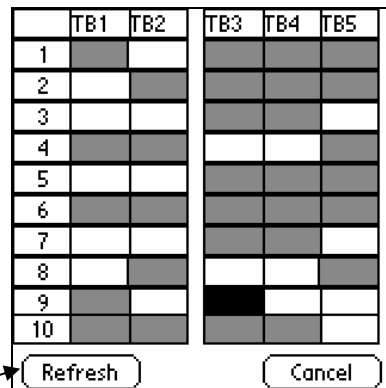

Step 18: View the I/O grid to verify the sensors and inputs. Press **Refresh** as needed to update the I/O. Black indicates input/output contact is closed. White indicates input/output contact is open. Gray never changes.

5.2 Tuning In the MC521 Controller Using the Controller Pushbuttons

NOTES

1. To change the INDEX:
Hold ENTER switch while pressing UP or DOWN to get to desired INDEX
2. To change the VALUE:
After the desired INDEX is selected release ENTER and press UP or DOWN to get the desired VALUE..
3. To display STAUS CODE:
A few seconds after the VALUE is selected the display indicates the STATUS CODE
4. To show the INDEX and VALUE
To show the INDEX hold ENTER, once released ENTER the display will show the VALUE of that INDEX.
5. Read the descriptions entirely before performing each step. Check the INDEX and VALUE after each step.

Table 1. FIS Procedure using Pushbuttons

Step	Description	Display		
		Index	Value	Status Code
1	Set Function switch to "Closed."			
2	Turn power on.			
3	Unlock keypad.	99	00	00
4	Restart FIS.	96	01	A0
5	Select door type: Slide, <u>01</u> single motor or <u>02</u> dual motor.	00	01 (single) 02 (dual)	A0
6	Select handing: <u>00</u> Right or <u>01</u> Left. Manually open door noting rotation of belt pulleys. If counter clockwise (CCW) use right hand during FIS. If clockwise (CW) use left hand during FIS.	01	00 (right) 01 (left)	A0
7	Accept FIS. As soon as the VALUE is changed to 01, display will go to 30 (Open Speed value) and then to A1. (Note: 30 is the default value.) When A1 is displayed go to next step.	03	01	A1
8	Make changes: Function switch <u>01</u> Rocker or <u>00</u> Rotary. The INDEX will start at 00.	11	01 rocker 00 rotary	A1
9	WARNING: During this sequence the sensors are inactive and the door has no SAFETY. To stop the door, turn power off or put the doors into breakout. Function switch: Switch to OPEN, momentarily, then CLOSED/LOCKED. Wait for the learn sequence to end. Display will show <u>A2</u> when finished.			A2
10	Lock keypad.	99	01	00
11	Final Tune in.			

Table 2. Index List

Index	Description
00-89	Settings Values, see Table 3.
90-95	Reserved.
96	Command - Restart FIS. Entering "01" will cause FIS to restart.
97	Command - Update EEPROM. Entering "01" will update operating parameters.
98	Command - Restart auto configuration. Entering "01" will cause auto configuration.
99	Command - Lock. Entering "01" will lock all value inputs except this index. This prevents inadvertent changes to input values. Values may be unlocked by entering "00" in this index.

Table 3. Settings

Index	Min. Value	Max. Value	Description	Defaults	
				Single	Dual
00	05	35	Open speed, increment by 1.	30	30
01	05	12	Close speed, revolutions per second.	10	10
02	03	10	Check speed, revolutions per second.	04	04
03	00	99	Open check length, percent of full opening.	--	--
04	00	99	Close check length, percent of full opening.	--	--
05	00	99	Reduced open position, percent of full opening (00=full open, 99=full close).	--	--
06	01	99	Hold open delay (0 to 25 sec.).	03	03
07	00	01	Lock Logic, 01 = Fail Secure, Note: Always set to 01 Fail Secure.	01	01
08	00	99	Open torque, percent of full scale.	33	33
09	00	99	Close torque, percent of full scale.	22	15
10	00	99	Check torque, percent of full scale.	24	15
11	00	02	Dura-Glide function switch type: 00=double pole rotary, 01=rocker, 02=single pole rotary (Single pole rotary not available until further notice).	01	01
12	00	01	2S Operation, 0=off, 1=on	00	00
13	01	99	Obstruction Time Delay (.01 – 2.55 sec) Heavy and dual motor doors may require a longer obstruction time (45 on buttons or 1.0 sec. on Palm).	11	11
14	00	60	*Open Acceleration, (larger value=faster acceleration).	07	07
15	00	60	*Open Braking, (larger value=increased braking).	08	08
16	00	60	*Close Acceleration, (larger value=faster acceleration).	04	04
17	00	60	*Close Braking, (larger value=increased braking).	02	02

*** These parameters are only available on software revision C (5.19) and higher.**

Table 4. Status Codes

Status Code	Description
00	Normal operation—All OK.
20	Breakout.
A0	First installation sequence (FIS).
A1	Auto-configuration sequence.
A2	Auto-configuration confirmation sequence.
b0	Invalid mode.
b1	Encoder error.

5.3 Final Tune-In Adjustments

- 5.3.1 Refer to ANSI A156.10, "American National Standard for Power Operated Doors," and DETERMINE ANSI door operating requirements.
- 5.3.2 IF Stanguard threshold sensor is installed, refer to Stanley Access Technologies document No. 203768, "Stanguard™ Threshold Sensor Installation and Operation," and TUNE-IN Stanguard threshold sensor.
- 5.3.3 IF SU-100 motion sensor(s) are installed, refer to Stanley Access Technologies document No. 203957, "SU-100 Motion Sensor Installation and Operation," and TUNE-IN SU-100 motion sensor(s).
- 5.3.4 IF OA-203C presence sensor(s) are installed, refer to manufacturer's instructions and TUNE-IN OA-203C presence sensor(s).
- 5.3.5 To ensure that all settings have been stored in EEPROM memory, turn power OFF and then back ON. Repeat step 5.3.1.

5.4 Spare Parts List

Description	Part Number
MC521 Controller, includes 3 terminal blocks	185000
MC521 Controller Manual	204003
Harness, Rocker Switch to Control Box, 98 inches	414098
Harness, Rocker Switch to Control Box, 180 inches	414099
Harness, Holding Beam to Control Box, 24 inches	414106
Harness, Rotary Switch to Control Box, 180 inches	414107 - 1
Harness, Rotary Switch to Control Box, 480 inches	414107 - 2
Harness, Holdbeam/Breakout, 48 inches	414111
Harness, Power, 18 inches	415000
Harness, Encoder Cable Adapter, 12 inches	415001
Harness, Solenoid Lock, Power/Signal, 61 inches	516823 - 1
Harness, Solenoid Lock, Power/Signal, 85 inches	516823 - 2
Harness, Solenoid Lock, Power/Signal, 142 inches	516823 - 3
Adapter, Female DB9 to RJ11	516826
Harness, Phone Cord, 50 feet	713911
Harness, Phone Cord, 25 feet	713911-1
Terminal Block Plug, 10 position	714055
Harness, motor, 14 feet	413362
Harness, motor, 17 feet	413362-1
Harness, line connect, 6 feet	412544
Harness, line connect, 10 feet	412545
Harness, Rocker Switch to Control Box, 252 inches	414126
Harness, Solenoid Lock Power Signal, 264 inches	516823-4
Harness Motor Extension, 42 inches	411746

Attachment 1

MC521 Controller Controls and Indicators

(Sheet 1 of 2)

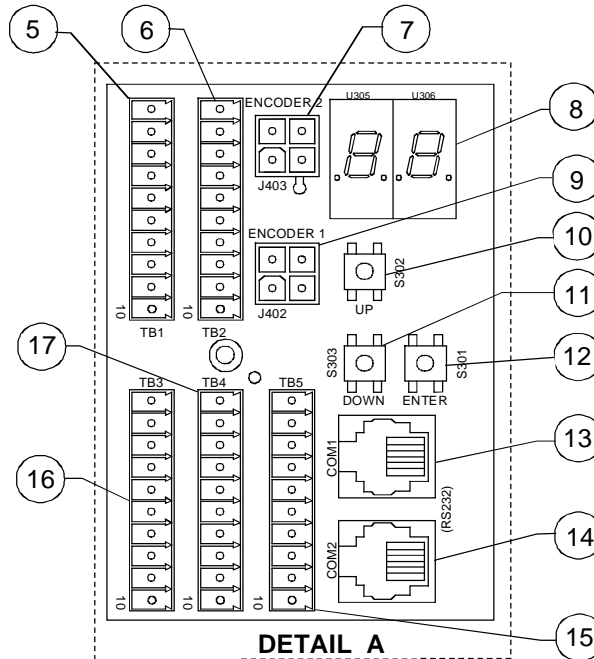
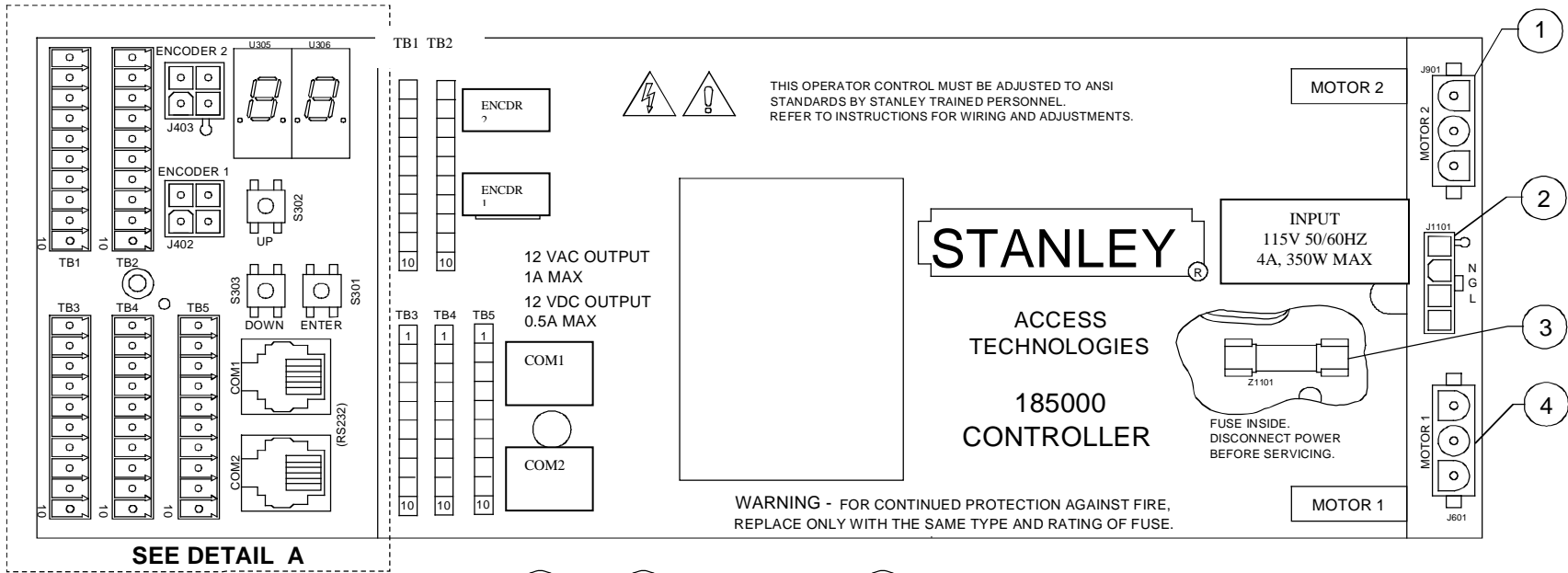

Attachment 1
MC521 Controller Controls and Indicators
(Sheet 2 of 2)

ITEM	CONTROL/ INDICATOR	DESCRIPTION
1	Motor 2 Connector J109	Motor No. 2 connector.
2	Power Connector J1101	Connection point for incoming line, neutral, and common power wiring.
3	Fuse Z1101	Controller fuse-- 5 Amp, 250V
4	Motor 1 Connector J601	Motor No. 1 connector.
5	Terminal Block Connector TB1	Connection point for door cycle counter and solenoid lock control.
6	Terminal Block Connector TB2	Connection point for function switch (rotary or rocker).
7	Encoder 2 Connector J403	Not Used
8	Two Digit Display	Displays Controller Status. Also serves as the display for tune-in by pushbutton switches.
9	Encoder 1 Connector J402	Connection point for motor encoder No. 1.
10	Up Pushbutton Switch S302	Used manual setup and tuning of door when PDA is not available.
11	Down Pushbutton Switch S303	Used for manual setup and tuning of door when PDA is not available.
12	Enter Pushbutton Switch S301	Used for manual setup and tuning of door when PDA is not available.
13	COM1 Jack	RS232 COM1 connector. Connection point for PDA harness.
14	COM2 Jack	RS232 COM2 connector. Future provision.
15	Terminal Block Connector TB5	Connection point for side-screen sensor and closed position switch.
16	Terminal Block Connector TB3	Connection point for Stanguard, doorway holding beam, and breakout switch. Using jumper wires across TB3 terminals 1 to 5 and 2 to 6, internal transformer supplies power to multiple external sensors.
17	Terminal Block Connector TB4	Connection point for inside sensor, outside sensor and push plate.

Attachment 2

MC521 System Wiring Diagram

(Sheet 1 of 3)

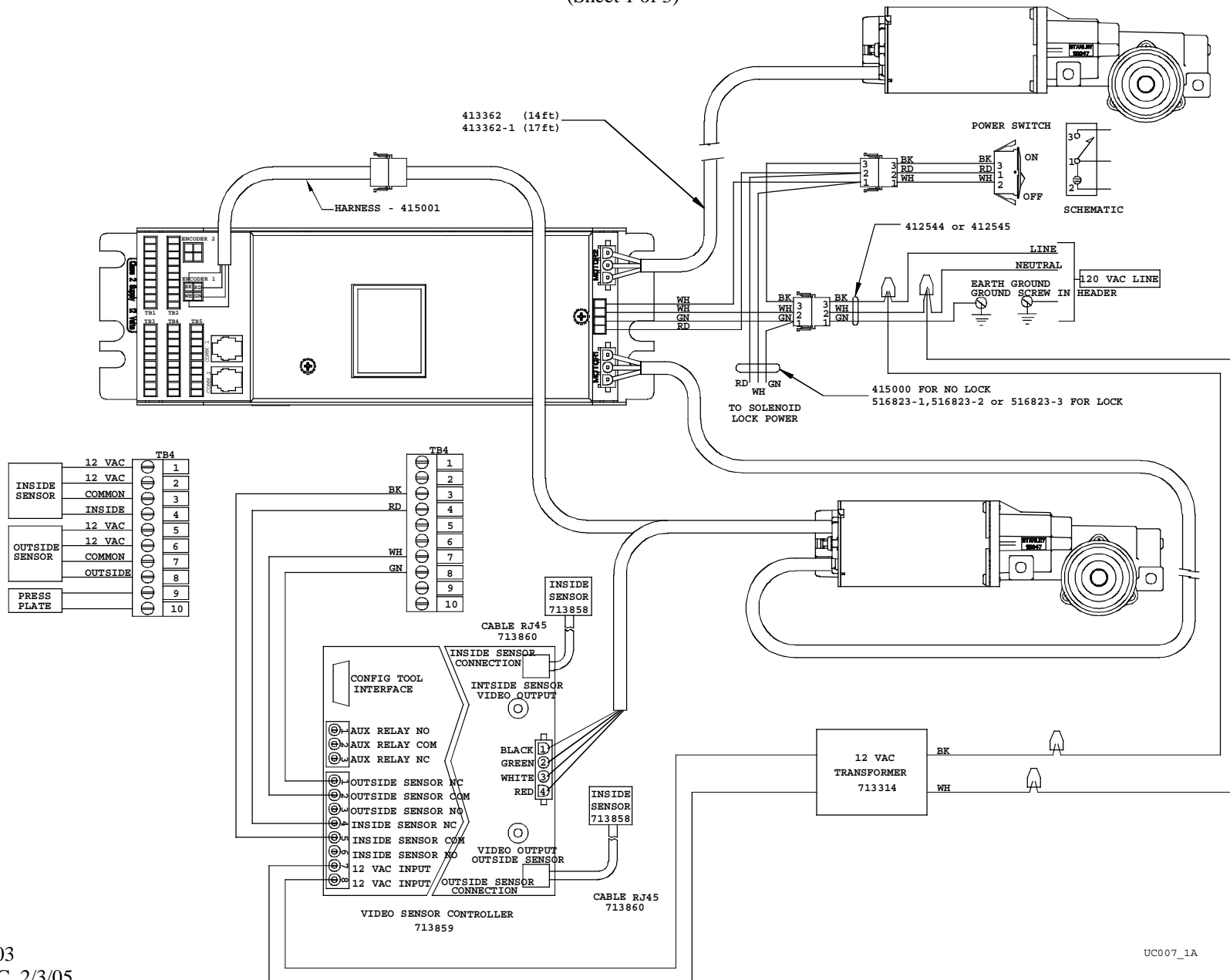

Attachment 2

MC521 System Wiring Diagram

(Sheet 3 of 3)

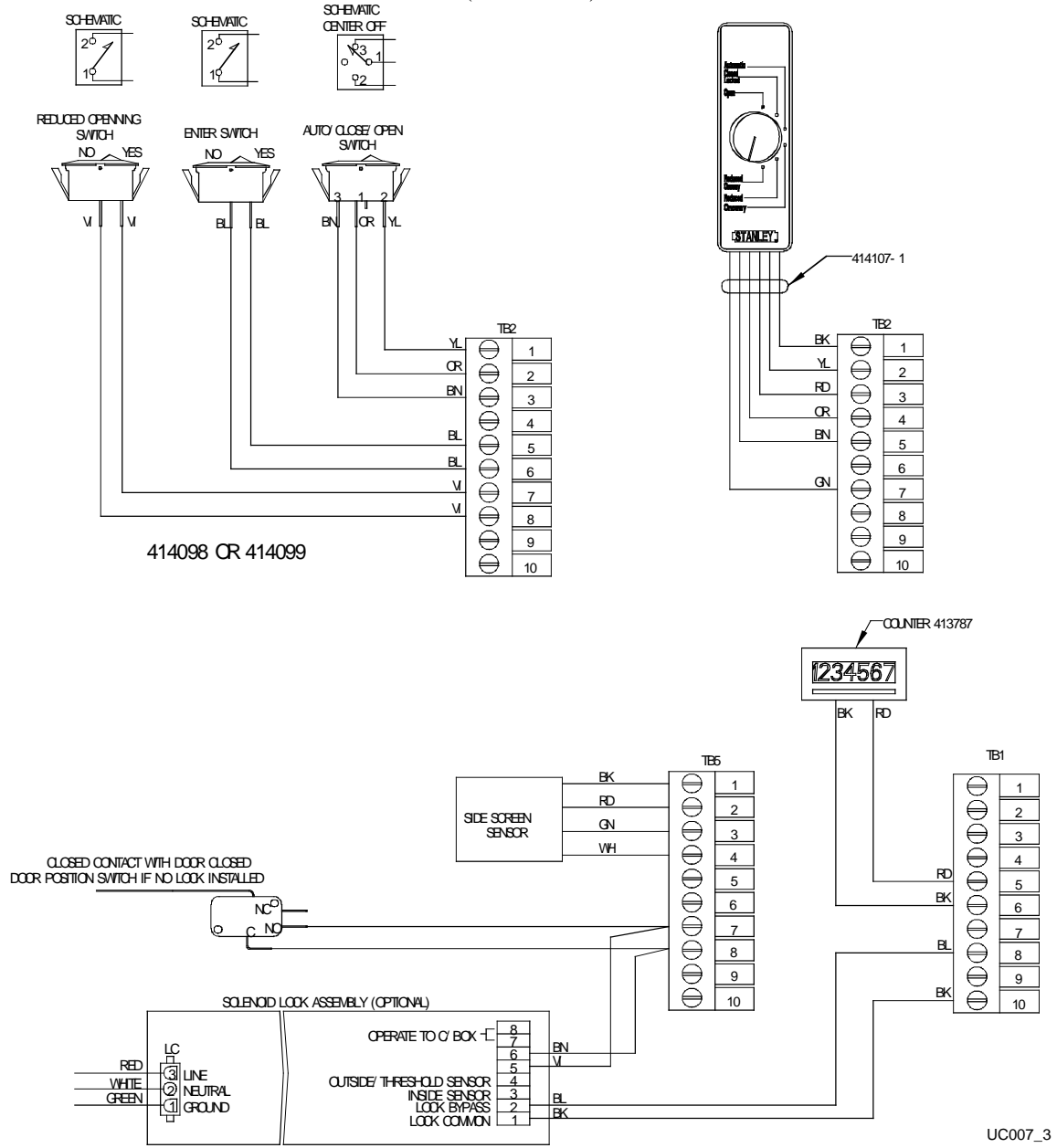

Attachment 3

MC521 Terminal Block Connections —TB1 through TB5

(Sheet 1 of 1)

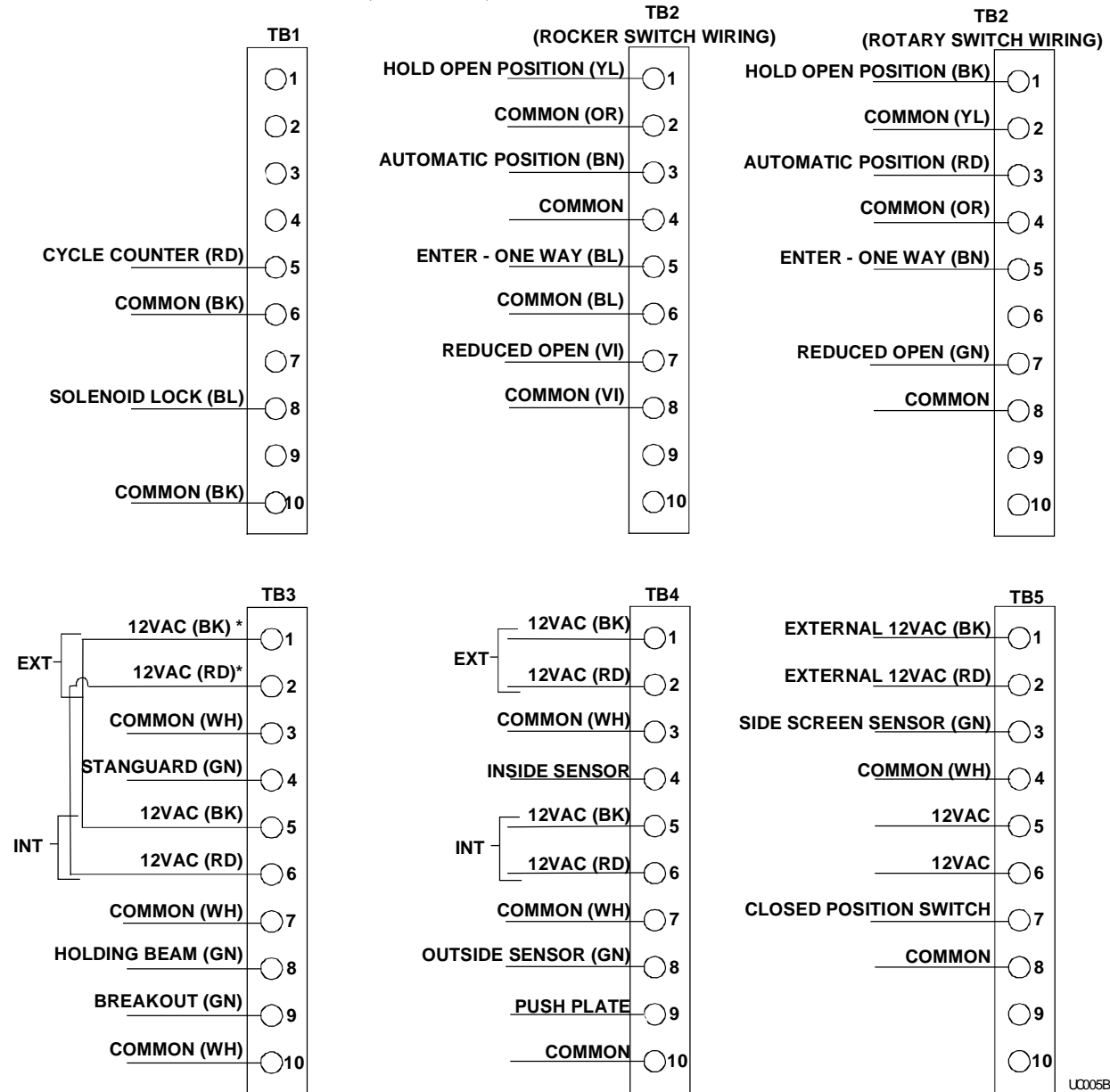

* REMOVE IF EXTERNAL POWER SUPPLY IS USED.

204003

Rev. C, 2/3/05

Page 17 of 17

© 2005, THE STANLEY WORKS. ALL RIGHTS RESERVED.

UC005B