

STANLEY MP CONTROL WITH PARALLAX 2 SYSTEM (LO21S)

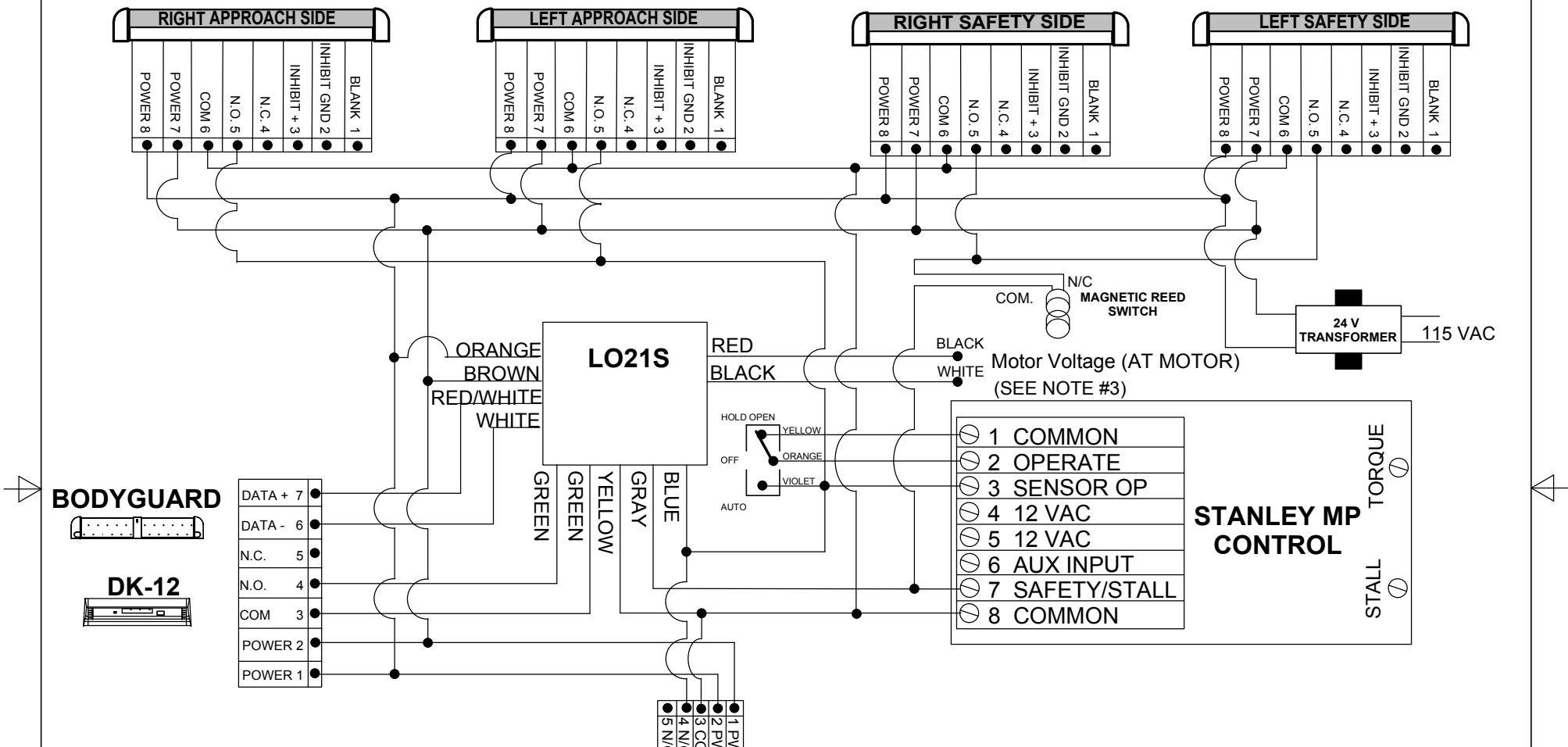

BODYGUARD

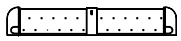

DK-12

DATA + 7	●
DATA - 6	●
N.C. 5	●
N.O. 4	●
COM 3	●
POWER 2	●
POWER 1	●

1	PWR
2	PWR
3	COM
4	N/O
5	N/C

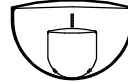

EAGLE

- NOTES:**
- CONTROL BOX DIPSWITCH #1 MUST BE SET TO OFF.
 - TORQUE IF APPLICABLE AND STALL ADJUSTMENTS MAY NEED TO BE INCREASED FOR LO21S PROPER OPERATION.
 - SHOWN LH,RH MAGIC SWING AND RH MAGIC FORCE FOR LH MAGIC FORCE REVERSE LO21S RED AND BLACK WIRES.



B.E.A., Inc.
 100 Enterprise Drive Pittsburgh, PA 15275
 PH: (412) 249-4100 FAX: (412) 249-4101
www.beasensors.com

TITLE: STANLEY MP CONTROL WITH PARALLAX 2 SYSTEM (LO21S)

SIZE: CAGE CODE: A	DWG NO: 80.0121	FILE OF: ENG'G	DRAWN BY: JED	REV: 02
SCALE: NONE	DATE: 05 JAN 04	SHEET: 1 OF 1		