

Stanley Access Technologies

Installation Manual



Magic-Force™ Operator Installation Instructions

Quick-Reference Guide

203967

Rev. C, 4/26/01

Prohibition on Copying

Any unauthorized reproduction, disclosure or distribution of copies by any person of any portion of this work may be a violation of copyright law of the United States of America and other countries, could result in the awarding of statutory damages of up to \$250,000 (17 USC 504) for infringement, and may result in further civil and criminal penalties. All rights reserved.

Stanley Access Technologies

Quick-Reference Guide

TABLE OF CONTENTS

1. PURPOSE 2

1.1 Discussion 2

1.2 Applicability 2

2. PREREQUISITES 2

3. PRECAUTIONS 2

4. INSTALLATION INSTRUCTIONS 3

4.1 Installing the Operator in the Header (Concealed Application)..... 3

4.2 Installing the Operator in the Header (Visible Out-Swing and In-Swing Applications) 6

4.3 Performing the Closeout Procedure 10

4.4 Replacement Parts 10

ATTACHMENTS

Attachment 1, Documents, Definitions, Special Tools, Equipment, and Consumables 11

Attachment 2, Magic-Force Operator Cam Settings 12

Attachment 3, Magic-Force Operator Open Stop Settings 13

Attachment 4, Magic-Force Operator Spring Tension Adjustment 14

Attachment 5, Magic-Force Operator Replacement Parts 15

1. PURPOSE

1.1 **Discussion**

This manual provides instructions for installing the Magic-Force operator in concealed and visible applications. The visible application installations cover both in-swing and out-swing doors. This manual also provides a listing of the Magic-Force operator replacement parts.

This manual is intended for use by Stanley authorized personnel.

1.2 **Applicability**

This manual is applicable to the Stanley Access Technologies Magic-Force™ operator.

2. PREREQUISITES

2.1 Protective barrier (caution/warning tape) has been set up to prevent unauthorized access to installation area.

2.2 Attachment 1 has been reviewed for the following:

- Definitions of the terms used in this procedure
- A listing of the additional documents required during this procedure
- A listing of the tools, equipment, personnel, and consumables used in this procedure.

3. PRECAUTIONS

3.1 Personal protective equipment such as safety glasses, steel-toe shoes, hearing protection, and hard hats must be used in all designated working areas.

3.2 When running power cords, make certain there are no trip hazards.

3.3 Block off work area to protect unauthorized personnel from hazards during work.

4. INSTALLATION INSTRUCTIONS

4.1 **Installing the Operator in the Header (Concealed Application)**

NOTE

1. This section describes installation of the operator in the header. It is assumed that the door jambs and header have already been installed and the door panel has been removed.
2. When the operator is shipped from the factory, the breakout and breakout status cams are set for right hand orientation and the open stop is set at 90°.

4.1.1 ENSURE jambs and header are installed and the door is removed.

4.1.2 INSTALL control box in header.

4.1.3 IF operator is a right hand application, Refer To Attachment 2, and PERFORM initial cam settings as follows:

- a. Looking down at the operator spindle, ROTATE breakout cams *counterclockwise* until raised portion of breakout status cam just contacts switch roller as shown.
- b. Looking down at the operator spindle, ROTATE close check cam *clockwise* until raised portion of cam actuates switch, and then ROTATE 10° *counterclockwise*.
- c. ADJUST auxiliary cam as desired.

4.1.4 IF operator is a left hand application, Refer To Attachment 2, and PERFORM initial cam settings as follows:

- a. Looking down at the operator spindle, ROTATE breakout cams *clockwise* until raised portion of breakout status cam just contacts switch roller as shown.
- b. Looking down at the operator spindle, ROTATE close check cam *counterclockwise* until raised portion of cam actuates switch, and then ROTATE 10° *clockwise*.
- c. ADJUST auxiliary cam as desired.

CAUTION

1. To prevent damage to the operator, the open stop must be installed *before* operating the unit.
2. Adjusting the open stop to a position greater than 135° will damage the operator.

4.1.5 ENSURE the open stop is installed.

NOTE

1. When the operator is shipped from the factory, the open stops are set at 90°.
2. The open stop is adjustable from 80° to 135°. There are five mounting holes for the open stop. Each hole provides approximately 12° of adjustment.

4.1.6 Refer To Attachment 3, and PERFORM preliminary open stop adjustment.

4.1.7 POSITION operator in header.

4.1.8 INSTALL and TIGHTEN four fasteners securing operator to header.

4.1.9 POSITION door arm onto operator spindle, and ENSURE door arm is parallel to header.

4.1.10 TIGHTEN fastener securing door arm to operator spindle.

CAUTION

If the motor is running and the breakout status switch is *not* connected, arcing across the breakout status switch contacts can occur, resulting in damage to the breakout switch. To prevent damage from switch contact arcing, the breakout status switch must *always* be connected.

4.1.11 CONNECT the following to control box:

- Breakout switch wiring
- Motor wiring
- Encoder wiring
- Switch wiring
- Incoming electrical power wiring

4.1.12 SET door function switch to “HOLD OPEN,” and OBSERVE door opens.

4.1.13 POSITION heel of door onto bottom pivot.

4.1.14 LIFT door, and POSITION top of door under door arm.

4.1.15 IF necessary, SHIM between door and door arm as required.

4.1.16 Using the pivot screw supplied or phillips screwdriver, ALIGN pivot bearing with door portion of bottom pivot.

4.1.17 INSTALL pivot screw through pivot and door portion of bottom pivot, and SECURE door to pivot.

4.1.18 LOOSEN fastener securing door arm to operator spindle, and POSITION door arm onto shim plate.

4.1.19 ALIGN holes in shim plate with holes in door.

4.1.20 INSTALL and TIGHTEN screws and lockwashers securing door arm to door.

4.1.21 TIGHTEN fastener securing door arm to operator spindle.

4.1.22 SET door function switch to “ON,” and OBSERVE door closes.

4.1.23 Manually CYCLE door open and closed, and ENSURE door opens and closes freely.

4.1.24 Manually CYCLE door open and closed, and INSPECT open stop for the following:

- Door stops before hitting anything.
- Door stops at the required position.

4.1.25 IF open stop is not properly set, PERFORM the following:

WARNING

To prevent injury to personnel, power to the operator must be disconnected whenever adjusting the open stop.

a. DISCONNECT electrical power to operator.

- b. OPEN door as necessary to access open stop, and temporarily SECURE door in that position.
 - c. REMOVE fastener securing open stop in place.
 - d. POSITION open stop in desired location, and ENSURE teeth on stop are properly engaged.
 - e. INSTALL and TIGHTEN fastener securing open stop in place.
 - f. CONNECT electrical power to operator.
 - g. REPEAT steps 4.1.24 and 4.1.25 as necessary.
- 4.1.26 IF door has a breakout stop, BREAK OUT door and INSPECT breakout stop for proper operation.
- 4.1.27 IF breakout stop is not properly set, PERFORM the following:

WARNING

To prevent injury to personnel, power to the operator must be disconnected whenever adjusting the breakout stop.

- a. DISCONNECT electrical power to operator.
 - b. OPEN door as necessary to access breakout stop, and temporarily SECURE door in that position.
 - c. REMOVE fastener securing breakout stop in place.
 - d. POSITION breakout stop in desired location, and ENSURE teeth on stop are properly engaged.
 - e. INSTALL and TIGHTEN fastener securing breakout stop in place.
 - f. CONNECT electrical power to operator.
 - g. REPEAT steps 4.1.26 and 4.1.27 as necessary.
- 4.1.28 Using a spring force gage positioned 1 inch from edge of door at leading stile, MEASURE force required to open door throughout *full* opening range.
- 4.1.29 IF necessary, ADJUST operator opening spring tension as follows:
- a. DISCONNECT motor and encoder harnesses from operator.
 - b. ROUTE motor and encoder harnesses through spring adjustment tool and INSERT adjustment tool into end of operator.

NOTE

1. Operator is shipped from the factory with the spring set to approximately 15 lbs. opening force for a 42-inch door.
2. Clockwise rotation of the spring adjustment tool *increases* spring tension. Counterclockwise rotation *decreases* spring tension.

- c. Refer To Attachment 4, and, using a screwdriver and spring adjustment tool, ADJUST spring to full energy, low energy, or local code requirement as applicable.
- d. REMOVE spring adjustment tool from operator.
- e. CONNECT motor and encoder harnesses to operator.
- f. REPEAT steps 4.1.28 and 4.1.29 as necessary.

4.1.30 CYCLE door open and closed several times, and INPECT close check function.

4.1.31 IF close check does *not* occur at greater than 10° of fully closed position, ADJUST close check cam as necessary.

4.1.32 PERFORM applicable action as follows:

- IF door has breakout, ENSURE breakout occurs at *less than* 5° of negative rotation.
- IF door does not have breakout, ENSURE breakout switch is *not* actuated.

4.1.33 ADJUST auxiliary cam as desired.

4.1.34 Refer To document No. 203959, “Magic-Swing™ and Magic-Force™ HDLE/FE Microprocessor Control Box Quick-Reference Guide,” and TUNE-IN door.

4.1.35 INSTALL header cover.

4.2 Installing the Operator in the Header (Visible Out-Swing and In-Swing Applications)

NOTE

1. This section describes installation of the operator in the header. It is assumed that the door jambs and header have already been installed and the door is mounted.
2. When the operator is shipped from the factory, the breakout and breakout status cams are set for right hand orientation.

4.2.1 ENSURE jambs and header are installed and the door is mounted.

4.2.2 Refer To document No. 203585, “Magic-Swing Installation and Tune-In Manual,” and INSTALL door arm onto door.

4.2.3 INSTALL control box in header.

CAUTION

1. To prevent damage to the operator, the open stop must be installed *before* operating the unit.
2. Adjusting the open stop to a position greater than 135° will damage the operator.

- 4.2.4 ENSURE the open stop is installed.
- 4.2.5 IF operator is a right hand application, Refer To Attachment 2, and PERFORM initial cam settings as follows:
- Looking down at the operator spindle, ROTATE breakout cams *counterclockwise* until raised portion of breakout status cam just contacts switch roller as shown.
 - Looking down at the operator spindle, ROTATE close check cam *clockwise* until raised portion of cam actuates switch, and then ROTATE 10° *counterclockwise*.
 - ADJUST auxiliary cam as desired.
- 4.2.6 IF operator is a left hand application, Refer To Attachment 2, and PERFORM initial cam settings as follows:
- Looking down at the operator spindle, ROTATE breakout cams *clockwise* until raised portion of breakout status cam just contacts switch roller as shown.
 - Looking down at the operator spindle, ROTATE close check cam *counterclockwise* until raised portion of cam actuates switch, and then ROTATE 10° *clockwise*.
- 4.2.7 POSITION operator in header.
- 4.2.8 Using four mounting screws, FASTEN operator to header.

CAUTION

If the motor is running and the breakout status switch is *not* connected, arcing across the breakout status switch contacts can occur, resulting in damage to the breakout switch. To prevent damage from switch contact arcing, the breakout status switch must *always* be connected.

- 4.2.9 CONNECT the following to control box:
- Breakout switch wiring
 - Motor wiring
 - Encoder wiring
 - Switch wiring
 - Incoming electrical power wiring
- 4.2.10 POSITION door arm onto operator spindle.
- 4.2.11 Using washer and screw provided, FASTEN door arm to bottom of operator spindle.
- 4.2.12 TIGHTEN door arm clamping bolt securing door arm to operator spindle.
- 4.2.13 IF door preload is required, PERFORM the following:
- ENSURE open stop is properly set.
 - SET door function switch to “HOLD OPEN.”
 - LOOSEN door arm clamping bolt securing door arm to operator spindle.

CAUTION

Excessive preload will *reduce* door-closing force.

- ROTATE door approximately 5 to 10° closed from full-open position.

e. TIGHTEN door arm clamping bolt securing door arm to operator spindle.

4.2.14 Manually CYCLE door open and closed, and INSPECT open stop for the following:

- Door stops before hitting anything.
- Door stops at the required position.

WARNING

To prevent injury to personnel, power to the operator must be disconnected whenever adjusting the open stop.

NOTE

The technique for adjusting the open stop on in-swing and out-swing applications is different. On an in-swing application, the operator must be rotated out of the header in order to access the stop.

4.2.15 IF door is an *in-swing* application, ADJUST open stop as follows:

- a. DISCONNECT electrical power to operator.
- b. REMOVE two fasteners securing spindle-end of operator to header.
- c. On cover-side of header, REMOVE fastener securing operator to header.
- d. SWING operator out of header as necessary to access open stop.
- e. REMOVE fastener securing open stop in place.
- f. POSITION open stop in desired location, and ENSURE teeth on stop are properly engaged.
- g. INSTALL and TIGHTEN fastener securing open stop in place.
- h. SWING operator into header.
- i. INSTALL and TIGHTEN all fasteners securing operator in header.
- j. CONNECT electrical power to operator.
- k. Manually CYCLE door open and closed, and INSPECT open stop for the following:
 - Door stops before hitting anything.
 - Door stops at the required position.
- l. IF open stop is not properly set, REPEAT step 4.2.15 as necessary.

4.2.16 IF door is an *out-swing* application, ADJUST open stop as follows:

- a. DISCONNECT electrical power to operator.
- b. OPEN door as necessary to access open stop, and temporarily SECURE door in that position.
- c. REMOVE fastener securing open stop in place.
- d. POSITION open stop in desired location, and ENSURE teeth on stop are properly engaged.

- e. INSTALL and TIGHTEN fastener securing open stop in place.
 - f. CONNECT electrical power to operator.
 - g. Manually CYCLE door open and closed, and INSPECT open stop for the following:
 - Door stops before hitting anything.
 - Door stops at the required position.
 - h. IF open stop is not properly set, REPEAT step 4.2.16 as necessary.
- 4.2.17 PERFORM applicable action as follows:
- IF door has breakout, ENSURE breakout occurs at *less than 5°* of negative rotation.
 - IF door does not have breakout, ENSURE breakout switch is *not* actuated.
- 4.2.18 CYCLE door open and closed several times, and INPECT close check function.
- 4.2.19 IF close check does *not* occur at greater than 10° of fully closed position, ADJUST close check cam as necessary.
- 4.2.20 Using a spring force gage positioned 1 inch from edge of door at leading stile, MEASURE force required to open door throughout *full* opening range.
- 4.2.21 IF necessary, ADJUST operator opening spring tension as follows:
- a. DISCONNECT motor and encoder harnesses from operator.
 - b. ROUTE motor and encoder harnesses through spring adjustment tool and INSERT adjustment tool into end of operator.

NOTE

1. Operator is shipped from the factory with the spring set to approximately 15 lbs. opening force for a 42-inch door.
2. Clockwise rotation of the spring adjustment tool *increases* spring tension. Counterclockwise rotation *decreases* spring tension.

- c. Refer To Attachment 4, and, using a screwdriver and spring adjustment tool, ADJUST spring to full energy, low energy, or local code requirement as applicable.
 - d. REMOVE spring adjustment tool from operator.
 - e. CONNECT motor and encoder harnesses to operator.
 - f. REPEAT steps 4.2.20 and 4.2.21 as necessary.
- 4.2.22 ADJUST auxiliary cam as desired.
- 4.2.23 Refer To document No. 203959, “Magic-Swing™ and Magic-Force™ HDLE/FE Microprocessor Control Box Quick-Reference Guide,” and TUNE-IN door.
- 4.2.24 INSTALL header cover.

4.3 **Performing the Closeout Procedure**

- 4.3.1 ENSURE door is secure.
- 4.3.2 ENSURE all metal and glass surfaces are clean.
- 4.3.3 ENSURE door installation area is clean and free of debris.
- 4.3.4 ENSURE Stanley service sticker and all decals/signage are properly displayed.
- 4.3.5 REMOVE caution tape or barriers from around installation site.
- 4.3.6 COMPLETE Work Order and REPORT your actions to the Construction Superintendent.

4.4 **Replacement Parts**

- 4.4.1 Refer to Attachment 5 for a listing of the Magic-Force operator replacement parts.

Attachment 1
Documents, Definitions, Special Tools, Equipment, and Consumables
(Sheet 1 of 1)

Documents

- Submittal drawings, work order, door specification, or customer construction documents, if available
- Document No. 203585, “Magic-Swing Installation and Tune-In Manual”
- Document No. 203959, “Magic-Swing™ and Magic-Force™ HDLE/FE Microprocessor Control Box Quick-Reference Guide”

Definitions

- None

Special Tools and Equipment (including, but not limited to)

- Allen wrench set
- Spring adjustment tool
- No. 3 phillips head screwdriver
- Small flathead screwdriver
- Spring force gage

Consumables (including, but not limited to)

- Caution/warning tape
- Clean rags
- Wire ties

Attachment 2

Magic-Force Operator Cam Settings

(Sheet 1 of 1)

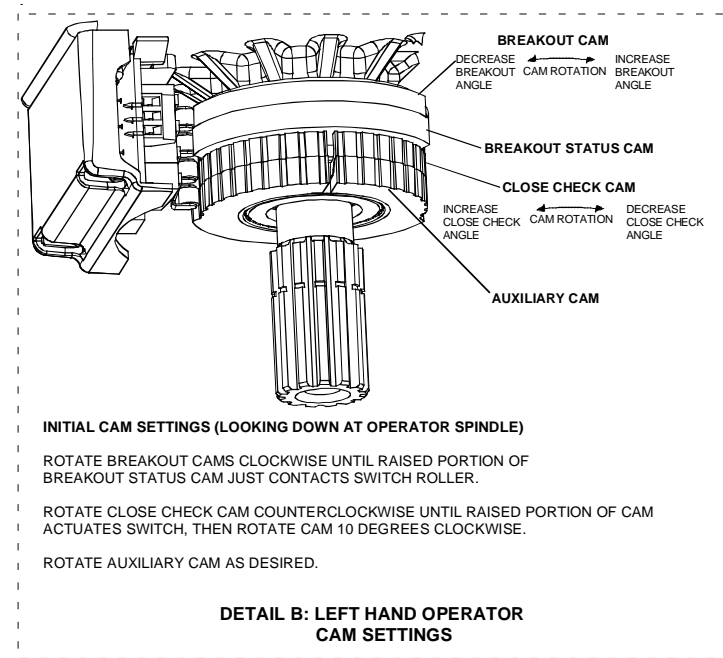
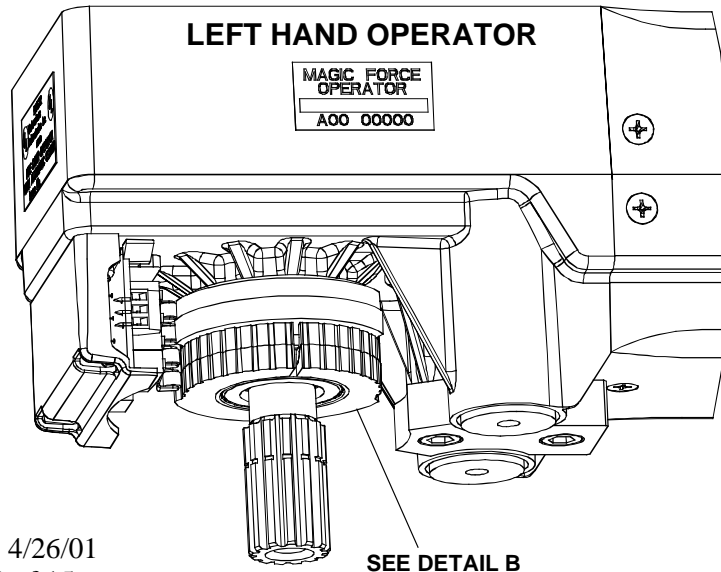
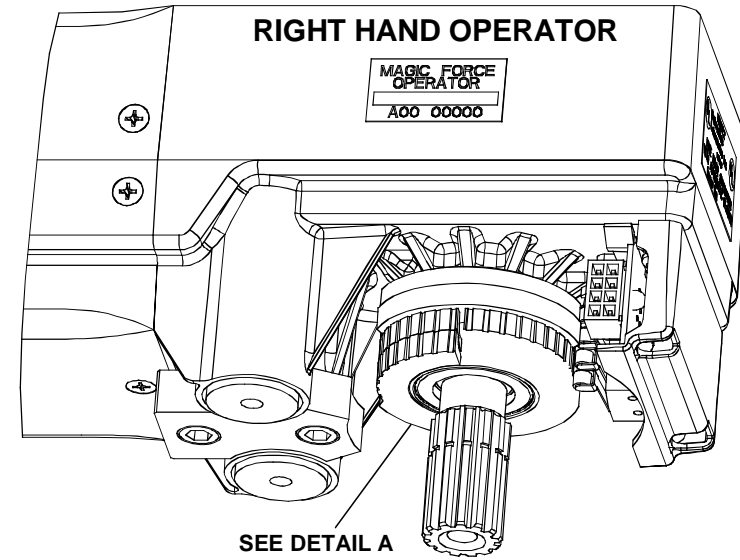
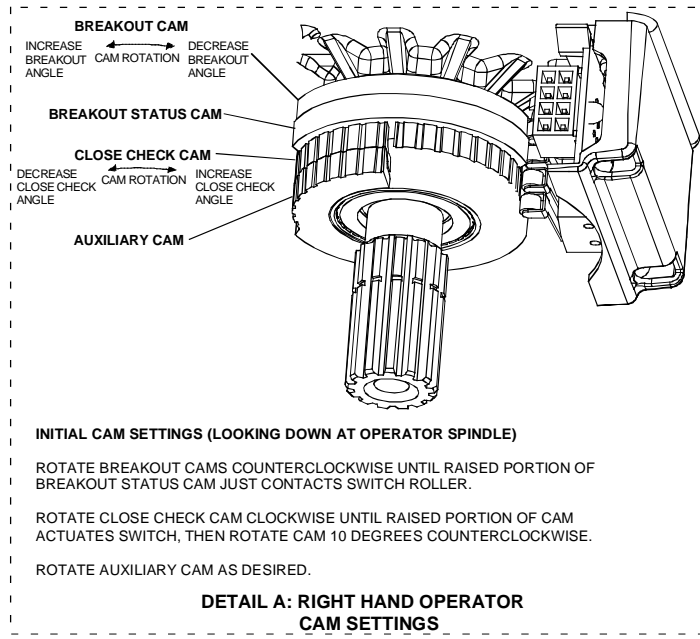

Attachment 3
Magic-Force Operator Open Stop Settings
 (Sheet 1 of 1)

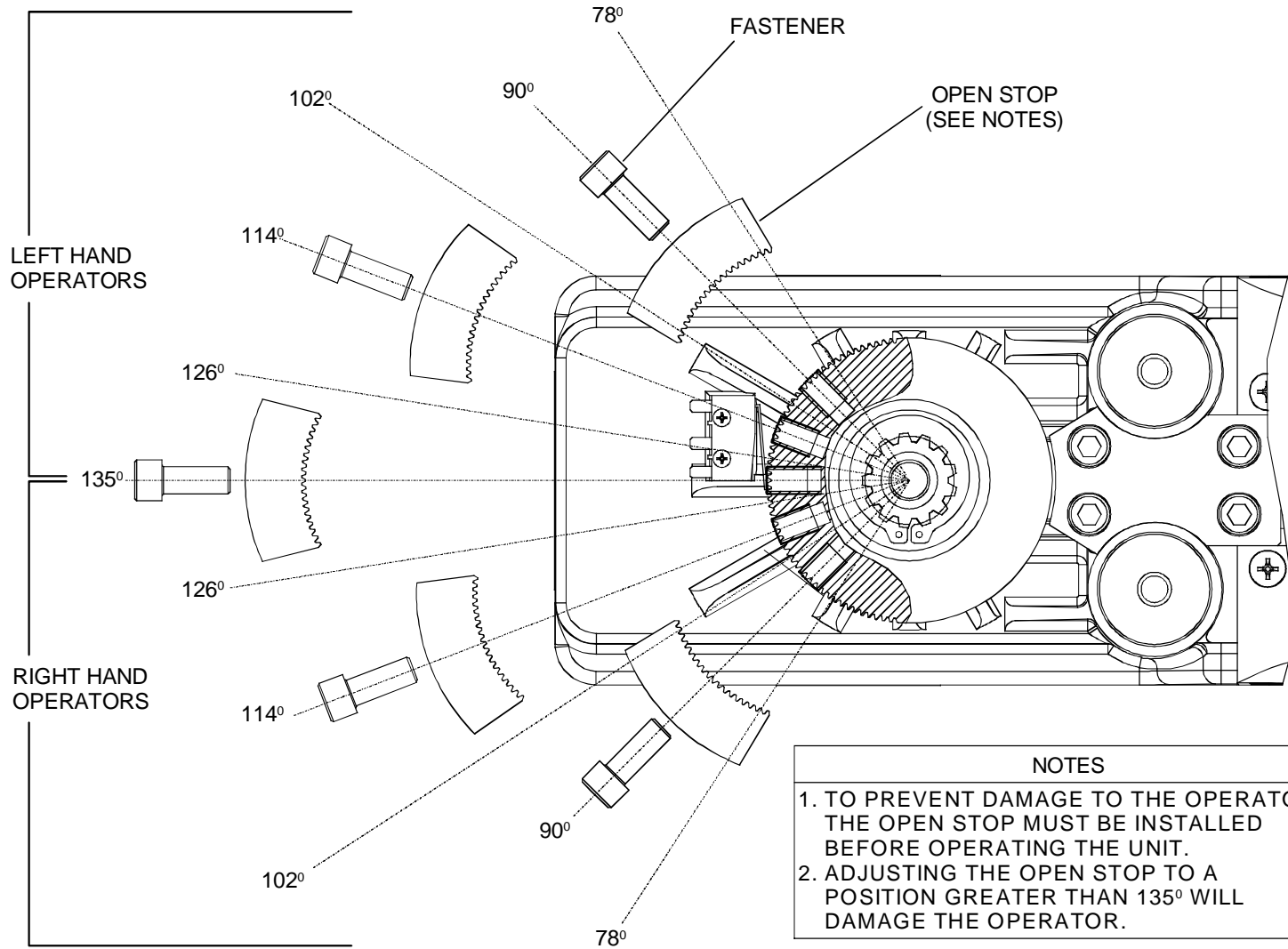

- | NOTES |
|--|
| 1. TO PREVENT DAMAGE TO THE OPERATOR, THE OPEN STOP MUST BE INSTALLED BEFORE OPERATING THE UNIT. |
| 2. ADJUSTING THE OPEN STOP TO A POSITION GREATER THAN 135° WILL DAMAGE THE OPERATOR. |

MF0025

Attachment 4
Magic-Force Operator Spring Tension Adjustment
(Sheet 1 of 1)

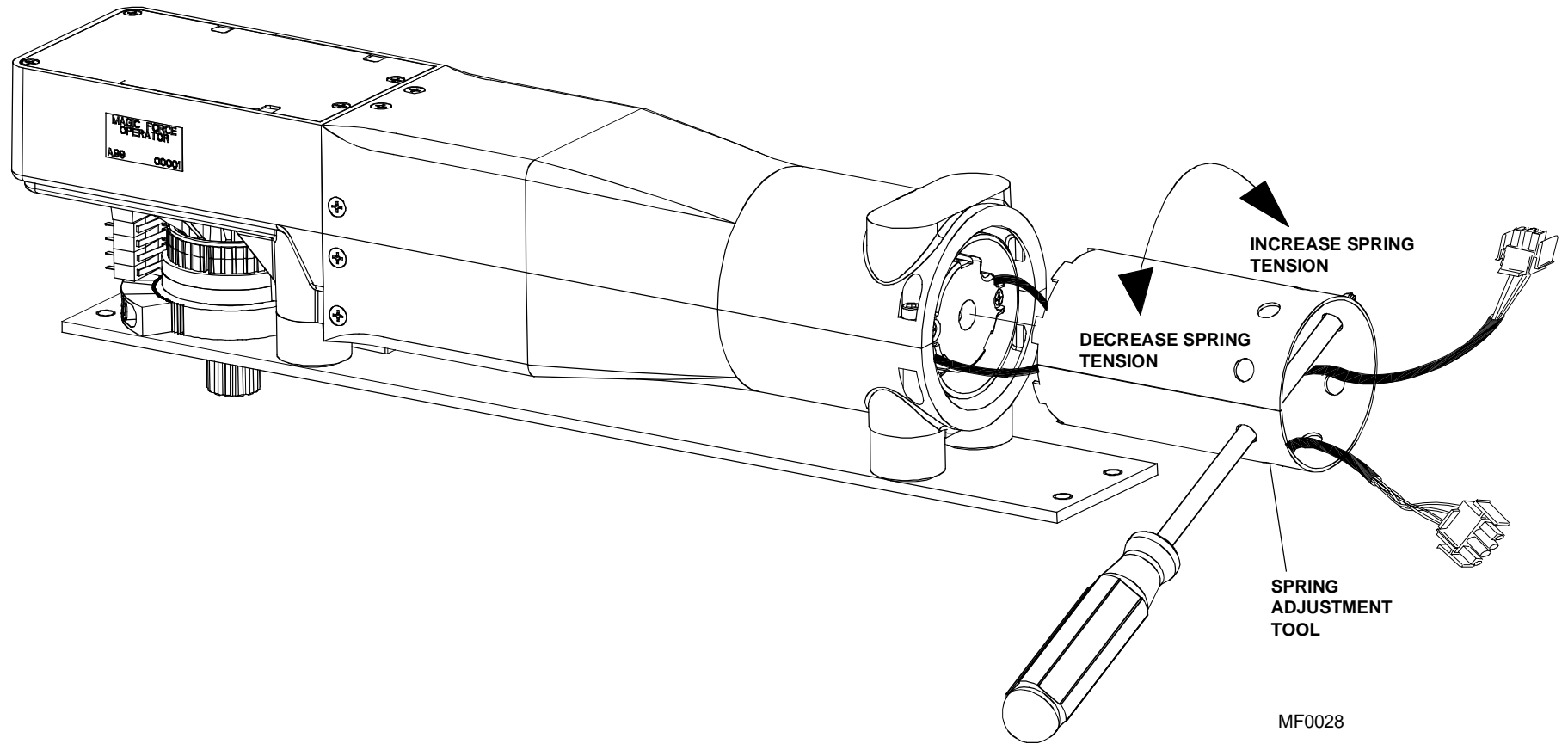

203967

Rev. C, 4/26/01

Page 14 of 15

© 2001, THE STANLEY WORKS. ALL RIGHTS RESERVED.

Attachment 5
Magic-Force Operator Replacement Parts
 (Sheet 1 of 1)

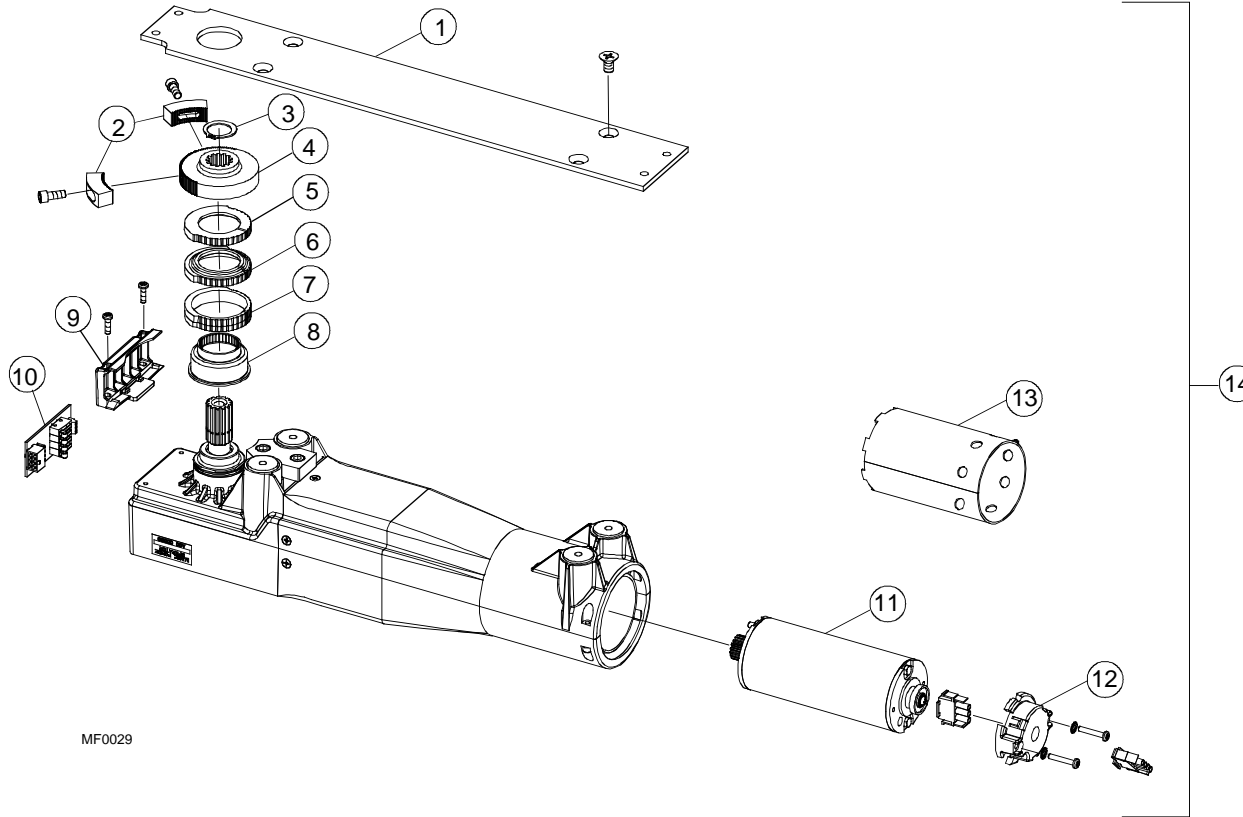

MF0029

Item No.	Part No.	Description	Item No.	Part No.	Description	Item No.	Part No.	Description
1	112074	Magic-Swing Adapter Plate	6	112038	Cam, Latch	11	112003	Motor Assembly
2	112037	Stop Mount Brackets	7	112035	Cam, Breakout	12	112006	Encoder Assembly
3	413779	Ring, Retaining	8	112040	Cam, Collar	13	112073	Spring Adjustment Tool
4	112039	Stop Cam	9	157643	Switch Module Housing	14	112000	Operator Assembly (Items 1-13)
5	112036	Cam, Auxiliary	10	516671	Switch Module, PC Board			

203967

Rev. C, 4/26/01

Page 15 of 15

© 2001, THE STANLEY WORKS. ALL RIGHTS RESERVED.