

Stanley Access Technologies  
**Quick-Reference Guide**



**Dura-Glide™ 2000-, 3000-, and 5000-Series; Dura-Guard™ 2000 and 3000-Series; Dura-Storm™ 3000-Series; and Diamond Series™ 2000- and 3000-Series  
Microprocessor Control Box  
Quick-Reference Guide**

**203728**

**Rev. B, 8/28/00**

**Prohibition on Copying**

Any unauthorized reproduction, disclosure or distribution of copies by any person of any portion of this work may be a violation of copyright law of the United States of America and other countries, could result in the awarding of statutory damages of up to \$250,000 (17 USC 504) for infringement, and may result in further civil and criminal penalties. All rights reserved.

**Quick-Reference Guide**

TABLE OF CONTENTS

1. PURPOSE.....	2
1.1 Discussion.....	2
1.2 Applicability.....	2
2. PREREQUISITES.....	3
2.1 Special Items Required.....	3
3. WIRING INSTRUCTIONS.....	3
3.1 Evaluating Power Requirements.....	3
3.2 Connecting Main Power Wiring.....	3
3.3 Connecting Door Position Switches Wiring (If Applicable).....	4
3.4 Connecting Stanguard Threshold Sensor Wiring.....	4
3.5 Connecting Doorway Holding Beam Wiring.....	4
3.6 Connecting Cycle Counter Wiring.....	4
3.7 Connecting Breakout Switch Wiring.....	4
3.8 Connecting Solenoid Lock Wiring (If Applicable).....	4
3.9 Wiring the Door Activation Devices.....	4
4. TUNE-IN INSTRUCTIONS.....	5
4.1 Initial Tune-In Settings.....	5
4.2 Final Tune-In Adjustments.....	5
5. TROUBLESHOOTING RECOMMENDATIONS.....	9
<u>Attachments</u>	
Attachment 1, System Wiring Diagram—2000- and 3000-Series Sliders.....	10
Attachment 2, System Wiring Diagram—5000-Series Sliders.....	12
Attachment 3, Interface Board Controls and Indicators.....	14
Attachment 4, Microprocessor Control Box Controls and Indicators.....	15

## 1. PURPOSE

### 1.1 **Discussion**

This manual provides installation instructions, wiring instructions, tune-in instructions, and troubleshooting recommendations for the microprocessor control box used in the following Stanley door systems:

- Dura-Glide™ 2000-, 3000-, and 5000-Series
- Dura-Guard™ 2000 and 3000-Series
- Dura-Storm™ 3000-Series
- Diamond Series™ 2000- and 3000-Series

The header assembly is delivered complete with the operator, motor, encoder, single-board microprocessor control box, door function switches, Stanguard™ threshold sensor, and an interface board all assembled and tested. The door activation devices (SU-100 motion sensors, carpets, push plates, etc.), lock, rotary switch (if applicable), doorway holding beams, and door position switches must be installed and connected to the interface board.

The handicap hold-open function was removed 12/93, leaving the “RO” selected. The two-position up/down slide switches for brake mode, 2S logic, and handing were replaced with three-pin jumper configurations as of 11/91. Procedure steps that refer to these settings only address the jumper configurations. The jumper *must* be installed on a pair of pins for the control box to function properly.

Attachment 1 illustrates system wiring for 2000- and 3000-series sliders. Attachment 2 illustrates system wiring for 5000-series sliders. Attachment 3 illustrates the interface board controls and indicators. Attachment 4 illustrates the microprocessor control box controls and indicators.

### 1.2 **Applicability**

This manual is applicable to the microprocessor control box used in the following Stanley door systems:

- Dura-Glide™ 2000-, 3000-, and 5000-Series
- Dura-Guard™ 2000 and 3000-Series
- Dura-Storm™ 3000-Series
- Diamond Series™ 2000- and 3000-Series

Instructions for connecting optional accessories such as key switches and door alarm contacts are provided in separate installation manuals. This manual does not cover components installed or manufactured by other companies.

## 2. PREREQUISITES

### 2.1 **Special Items Required**

- 2.1.1 Stanley Access Technologies document No. 203957, "SU-100 Motion Sensor Installation and Operation" (if installed)
- 2.1.2 Stanley Access Technologies document No. 203768, "Stanguard™ Threshold Sensor Installation and Operation"
- 2.1.3 Optex OA-601 manufacturer's installation and tune-in instructions (if installed)
- 2.1.4 ANSI A156.10, "American National Standard for Power Operated Doors"
- 2.1.5 SU-100 tune-in remote control
- 2.1.6 Degreaser

## 3. WIRING INSTRUCTIONS

### 3.1 **Evaluating Power Requirements**

- 3.1.1 EVALUATE door system power requirements as follows:
  - ENSURE power source is a dedicated 117 VAC, 50/60 Hz source with 20A circuit rating.
  - ENSURE *no more than* four operators will be connected to one circuit.
  - ENSURE power source is *not* shared with other equipment, i.e., cash registers, EAS systems, or other electromagnetic interference generators.

### 3.2 **Connecting Main Power Wiring**

#### **WARNING**

1. To prevent injury to personnel, incoming electrical power to the header must be deenergized before connecting electrical service to the control box.
2. All electrical wiring must conform to National Electrical Code Requirements.

- 3.2.1 DEENERGIZE incoming electrical power to header.
- 3.2.2 ROUTE incoming power wires along top of the header track tube.
- 3.2.3 Refer to Attachment 1 or 2 as applicable, and, using a wire nut, CONNECT incoming electrical service ground wire to grounding screw in header.
- 3.2.4 Using wire nuts, CONNECT incoming line and neutral wires to control box internal wiring harness (black to black, white to white).
- 3.2.5 IF adhesive wire clamps will be used, DEGREASE metal surfaces on top of the header track tube where clamps will mount.
- 3.2.6 SECURE wiring to top of the header track tube, and ENSURE the following:
  - All wires are clear of belts and belt brackets.
  - Header cover opens and closes without interference.

### 3.3 **Connecting Door Position Switches Wiring (If Applicable)**

3.3.1 Refer to Attachment 1 or 2, and CONNECT the following to interface board terminal block TB1 as applicable.

- Rotary switch wiring
- “AUTO/CLS/OPN” switch wiring
- “ENTER” switch wiring
- “REDUCED OPENING” switch wiring
- “POWER” switch wiring

### 3.4 **Connecting Stanguard Threshold Sensor Wiring**

3.4.1 IF necessary, refer to Attachment 1 or 2 as applicable, and CONNECT Stanguard threshold sensor wiring to interface board terminal block TB3. (Typically factory wired.)

### 3.5 **Connecting Doorway Holding Beam Wiring**

3.5.1 Refer to Attachment 1 or 2 as applicable, and CONNECT doorway holding beam wiring to interface board terminal block TB3. (Typically factory wired.)

### 3.6 **Connecting Cycle Counter Wiring**

3.6.1 IF necessary, refer to Attachment 1 or 2 as applicable, and CONNECT cycle counter wiring to interface board terminal block TB3. (Typically factory wired.)

### 3.7 **Connecting Breakout Switch Wiring**

3.7.1 Refer to Attachment 1 or 2 as applicable, and CONNECT breakout switch wiring to interface board terminal block TB3.

### 3.8 **Connecting Solenoid Lock Wiring (If Applicable)**

3.8.1 Refer to Attachment 1 or 2 as applicable, and CONNECT solenoid lock wiring to interface board connector J4.

3.8.2 IF door is a 5000-series application, CONNECT solenoid lock mechanism assembly harness to solenoid lock PC board connector J2.

### 3.9 **Wiring the Door Activation Devices**

3.9.1 IF SU-100 motion sensor(s) are required, refer to Stanley Access Technologies document No. 203957, “SU-100 Motion Sensor Installation and Operation,” and INSTALL SU-100 motion sensor(s).

3.9.2 IF OA-601 motion sensor(s) are required, PERFORM the following:

- a. Refer to manufacturer’s instructions and INSTALL OA-601 motion sensor(s).
- b. Refer to Attachment 1, and CONNECT OA-601 motion sensor(s) wiring.

3.9.3 Refer to Attachment 1 or 2 as applicable, and CONNECT the following to interface board terminal block TB2 as applicable:

- SU-100 motion sensor(s) wiring
- OA-601 motion sensor(s) wiring
- Push plate wiring

#### 4. TUNE-IN INSTRUCTIONS

##### 4.1 **Initial Tune-In Settings**

###### **WARNING**

To prevent injury to personnel and damage to equipment, power to the control box must be deenergized *before* making initial tune-in settings.

4.1.1 SET "POWER" switch to "OFF."

4.1.2 Refer to Attachment 4, and SET control box potentiometers and switches to initial positions as follows:

- a. SET check speed potentiometer to 12 o'clock position.
- b. SET open speed potentiometer to full counterclockwise (minimum) position.
- c. SET close speed potentiometer to full counterclockwise (minimum) position.

###### **CAUTION**

The time delay potentiometer is glued to the "1" position. Do *not* attempt to change the switch setting.

- d. ALLOW time delay switch to remain set to "1."
- e. SET reduced opening switch to "1."
- f. SET check size switch to "1" or "2."
- g. SET normal/2S jumper to upper (normal operation) position.
- h. SET brake mode jumper to lower (minimum braking) position.
- i. SET handing jumper as follows:
  - IF door is a right hand or bi-part slider, SET jumper to lower position.
  - IF door is a left hand slider, SET jumper to upper position.

##### 4.2 **Final Tune-In Adjustments**

4.2.1 Refer to ANSI A156.10, "American National Standard for Power Operated Doors," and DETERMINE ANSI door operating requirements.

4.2.2 IF Stanguard threshold sensor is installed, refer to Stanley Access Technologies document No. 203768, "Stanguard™ Threshold Sensor Installation and Operation," and TUNE-IN Stanguard threshold sensor.

4.2.3 IF SU-100 motion sensor(s) are installed, refer to Stanley Access Technologies document No. 203957, "SU-100 Motion Sensor Installation and Operation," and TUNE-IN SU-100 motion sensor(s).

4.2.4 IF OA-601 motion sensor(s) are installed, refer to manufacturer's instructions and TUNE-IN OA-601 motion sensor(s).

- 4.2.5 SET "POWER" switch to "OFF."
- 4.2.6 Manually PUSH doors to fully closed position.

**NOTE**

In order to avoid interference from the motion sensors during final tune-in adjustments, only the open and close settings of the door function switch should be used unless otherwise specified.

- 4.2.7 SET "AUTO/CLS/OPN" switch to "CLS" or rotary switch to "Closed Locked."
- 4.2.8 SET "POWER" switch to "ON," and VERIFY that control box watchdog LED remains on as long as power is applied.
- 4.2.9 IF watchdog LED blinks on and off, refer to Section 5, and TROUBLESHOOT fault.
- 4.2.10 Manually PUSH doors to partially open position, and VERIFY that control box X and Y encoder LEDs blink as doors open.
- 4.2.11 IF control box X and Y encoder LEDs do *not* blink as doors move, refer to Section 5, and TROUBLESHOOT fault.
- 4.2.12 ROTATE check speed, open speed, and close speed potentiometers clockwise one third of full range.
- 4.2.13 CYCLE doors open and closed, and ADJUST check speed potentiometer as required.
- 4.2.14 IF doors open when they should close or close when they should open, SET control box handing jumper to the opposite position.

**NOTE**

The size of the opening check zone is approximately twice the size of the closing check zone. The check zone size may vary because of door inertia.

- 4.2.15 Refer to Table 1 and Attachment 4, and, using the check size switch, ADJUST check size as required.

**Table 1. Check Size Adjustment**

Check Size Switch Position	Check Zone Size	Check Size Switch Position	Check Zone Size
0	3"	8	11"
1	4"	9	12"
2	5"	10 or A	13"
3	6"	11 or B	14"
4	7"	12 or C	15"
5	8"	13 or D	16"
6	9"	14 or E	17"
7	10"	15 or F	18"

- 4.2.16 CYCLE doors open and closed, and ADJUST open and close speed potentiometers as required.
- 4.2.17 IF a door hold-open time delay is required, PERFORM the following as applicable:

- IF SU-100 motion sensor is installed, refer to Stanley Access Technologies document No. 203957, “SU-100 Motion Sensor Installation and Operation,” and ADJUST hold-open time delay as required.
- IF SU-100 motion sensor is *not* installed, INSTALL time delay isolator 312984, and ADJUST as required.

**NOTE**

The Stanguard threshold sensor may not allow the door to close if the reduced-opening size is too small.

- 4.2.18 IF door is equipped with a “REDUCED OPENING” switch or a rotary switch, PERFORM the following:
- SET reduced-opening switch to “ON” or rotary switch to “Reduced.”
  - Refer to Table 2 and Attachment 4, and, using the control box reduced-opening switch, ADJUST reduced-opening size as required.

**Table 2. Reduced-Opening Size Adjustment**

Reduced-Opening Switch Position	Reduced-Opening Size (Bi-Part)	Reduced-Opening Size (Single-Slider)	Reduced-Opening Switch Position	Reduced-Opening Size (Bi-Part)	Reduced-Opening Size (Single-Slider)
0	10"	5"	8	68"	34"
1	30"	15"	9	72"	36"
2	36"	18"	10 or A	76"	38"
3	42"	21"	11 or B	80"	40"
4	48"	24"	12 or C	84"	42"
5	54"	27"	13 or D	88"	44"
6	60"	30"	14 or E	92"	46"
7	64"	32"	15 or F	96"	48"

- CYCLE doors open and closed, and VERIFY proper operation of reduced-opening function.
- 4.2.19 SET brake mode jumper to upper position for maximum braking (heavy doors) or to lower position for minimum braking (lighter doors).
- 4.2.20 SET “AUTO/CLS/OPN” switch to “AUTO” or rotary switch to “Automatic.”
- 4.2.21 On interface board, SET “LOCK/NO LOCK” switch as follows:
- IF a solenoid lock is installed, SET “LOCK/NO LOCK” switch to “LOCK.”
  - IF a solenoid lock is *not* installed, SET “LOCK/NO LOCK” switch to “NO LOCK.”
- 4.2.22 VERIFY proper operation of all sensors.
- 4.2.23 VERIFY proper operation of breakout function.



#### NOTE

The door can be equipped with an “ENTER” switch or a multifunction rotary switch. The “ENTER” switch and the “ONEWAY” setting on the rotary switch only function when a solenoid lock or door position switch is installed. If a solenoid lock or door position switch is *not* installed, a jumper wire must be installed across pins 7 and 8 of interface board terminal block TB1.

- 4.2.24 IF an “ENTER” switch is installed, VERIFY proper operation of switch as follows:
- IF a door position switch or solenoid lock is *not* installed, INSTALL jumper wire across interface board terminal board TB1 pins 7 and 8.
  - VERIFY proper operation “YES” and “NO” switch settings.
- 4.2.25 IF a rotary switch is installed, VERIFY proper operation of “ONEWAY” switch setting as follows:
- IF a door position switch or solenoid lock is *not* installed, INSTALL jumper wire across interface board terminal board TB1 pins 7 and 8.
  - VERIFY proper operation “ONEWAY” switch setting.

#### NOTE

The method of adjusting opening and closing force depends on the model of control box installed.

- On the yellow control box, the torque potentiometer adjusts opening and closing force.
- On the heavy-duty orange control box, a two-position jumper plug labeled S9 allows selection of opening force adjustments. Setting the jumper to position A provides maximum opening force regardless of the torque potentiometer setting. (This is advantageous for heavy doors.) Setting the jumper to position B allows the torque potentiometer to control the opening force.

- 4.2.26 IF a yellow control box is installed, PERFORM the following:
- REMOVE control box cover.
  - Using an isolated screwdriver, ROTATE torque potentiometer as necessary to adjust opening and closing force.
  - WHEN opening and closing force adjustments are complete, INSTALL control box cover.
- 4.2.27 IF a heavy-duty orange control box is installed, PERFORM the following:
- REMOVE control box cover.
  - IF maximum opening force is desired, SET S9 jumper to position “A.”
  - IF opening force control is desired, SET S9 jumper to position “B,” and, using an isolated screwdriver, ROTATE torque potentiometer as necessary to adjust opening and closing force.

#### NOTE

The 2S logic feature is used in trained-traffic applications and is not compatible with sensors. The 2S logic feature allows the door(s) to open when an operate switch is pushed and close when the next sequential operate switch is pushed.

- SET normal/2S logic jumper to upper position to enable 2S logic or to lower position for normal operation.

## 5. TROUBLESHOOTING RECOMMENDATIONS

Table 3 provides a listing of control box related failure symptoms and troubleshooting recommendations.

**Table 3. Troubleshooting Recommendations**

Symptom	Recommended Remedy
With power on, the WD LED is off.	Check fuse. Verify that harness 412902-1 is plugged in to interface board connector J3 and to the signal and power connectors on the control box. Check fuse and replace if necessary.
With power on, the WD LED blinks on and off.	<ol style="list-style-type: none"> <li>1. Set "POWER" switch to "OFF."</li> <li>2. Wait 15 seconds.</li> <li>3. Set "POWER" switch to "ON."</li> <li>4. If watchdog LED continues to blink on and off, replace control box.</li> </ol>
The door will not move at first attempt and the WD LED is on.	Check breakout switch circuit. Check door for excessive drag. Rotate torque or check speed potentiometer clockwise.
Encoder LEDs do not blink when the door is moved by hand and WD LED is on.	Check encoder cable and connector.
Door opens when it should be closing and closes when it should be opening.	Set the control box handing switch or jumper to the opposite position.
Door tends to stall, particularly at slow speeds.	Test force at edge of door. If door stalls at a force of 5 lbs or less, increase door force using torque potentiometer.
Reduced opening size too wide or too narrow.	Adjust reduced-opening size using the control box reduced opening switch.
Close check size too small for a heavy door, preventing adjustment of desired door speed.	Increase close check size using the control box check size switch.
No operation. Encoder lights blink when door is moved by hand.	<ol style="list-style-type: none"> <li>1. Check motor and motor cable.</li> <li>2. Check breakout wiring loop.</li> <li>3. Rotate torque or check speed potentiometer clockwise.</li> <li>4. Manually move door to a different position. If operation resumes, check motor brushes and brush holders and replace as necessary.</li> </ol>
Door slams. Open and close speed adjustments are operating properly.	<ol style="list-style-type: none"> <li>1. Check encoder cable for disconnection or defects.</li> <li>2. Test for defective encoder as follows: <ul style="list-style-type: none"> <li>• SET "AUTO/CLS/OPN" switch to "CLS" or rotary switch to "CLOSED LOCKED." Set "POWER" switch to "OFF" and then "ON." The watchdog LED shall be on.</li> <li>• Move door slowly by hand while verifying operation of encoder LEDs.</li> <li>• Position door such that both encoder LEDs are off. For right hand operation, move the door slightly by hand and verify left encoder LED comes on when door is closing and right encoder LED comes on when door is opening. NOTE: Reverse this sequence when the handing is set for left hand operators.</li> </ul> </li> </ol>

**Table 3. Troubleshooting Recommendations**

<b>Symptom</b>	<b>Recommended Remedy</b>
Door slams. No speed adjustments.	Replace defective control box.
No operation with "AUTO/CLS/OPN" switch set to "AUTO" or rotary switch set to "Automatic." Manual operation with "AUTO/CLS/OPN" switch set to "OPN" or "CLS" functions properly.	<ol style="list-style-type: none"><li>1. Check sensor power supply at interface board terminals.</li><li>2. Check wiring of sensor(s). Check wiring of "AUTO/CLS/OPN" switch or rotary switch at interface board terminals.</li></ol>
No reduced-opening control.	<ol style="list-style-type: none"><li>1. Check "REDUCED OPENING" switch or rotary switch connections.</li><li>2. Check setting of reduced-opening size selector switch.</li></ol>
Jerky door operation. Or, doors slam open during initial tune-in.	Check encoder signal harness and motor harness. Make sure the two harnesses are physically separated from each other.
With "AUTO/CLS/OPN" switch set to "AUTO" or rotary switch set to "Automatic," the outside sensor will not activate the door.	<ol style="list-style-type: none"><li>1. Verify that the "ENTER" switch is in the "YES" position.</li><li>2. Verify the "LOCK/NO LOCK" switch on interface board is in "NO LOCK" position.</li></ol>

# Attachment 1

## System Wiring Diagram—2000- and 3000-Series Sliders

(Sheet 1 of 2)

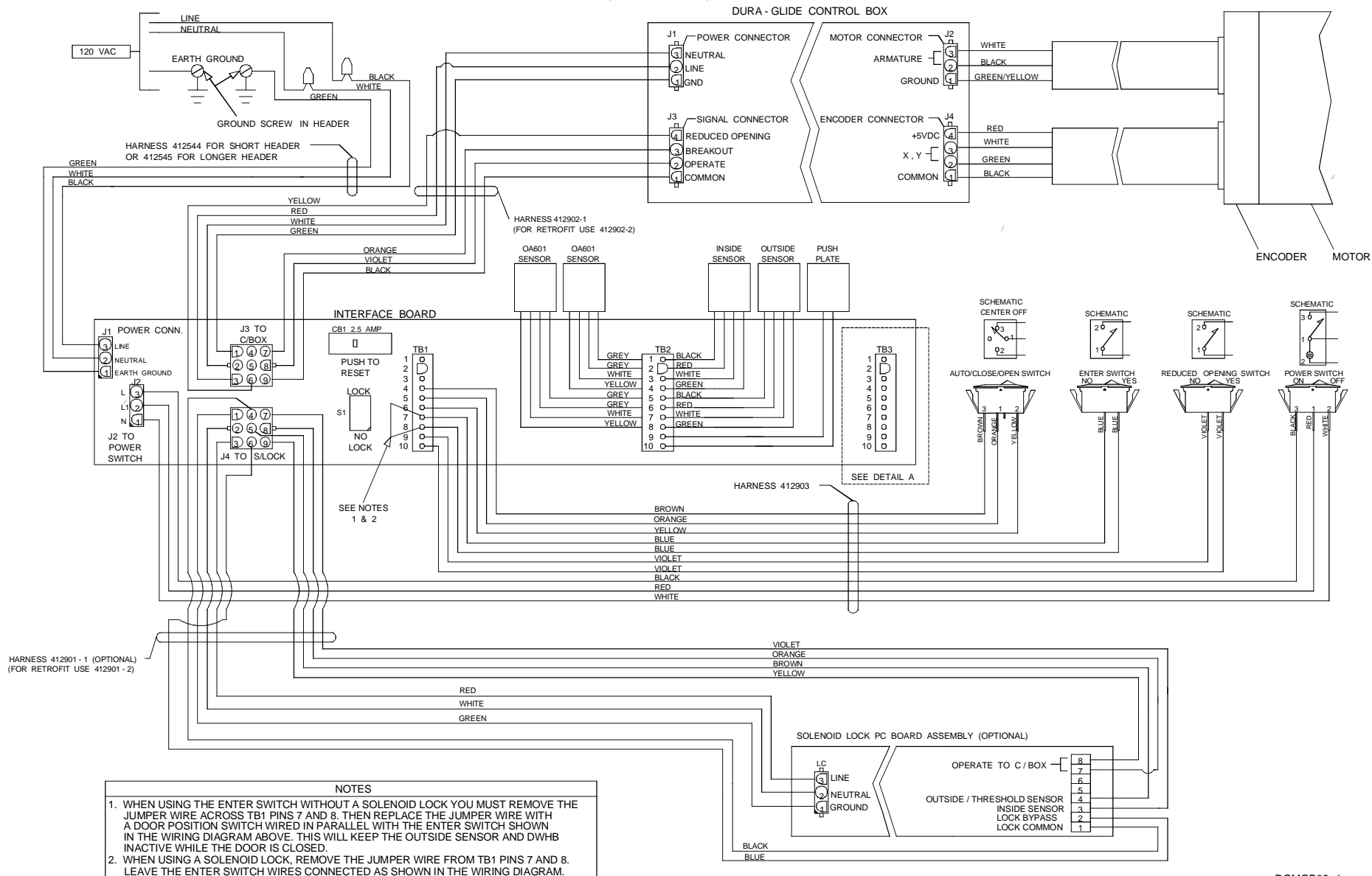

DGMCB02\_1

203728

Rev. B, 8/28/00

Page 11 of 18

© 2000, THE STANLEY WORKS. ALL RIGHTS RESERVED.

# Attachment 1

## System Wiring Diagram—2000- and 3000-Series Sliders

(Sheet 2 of 2)

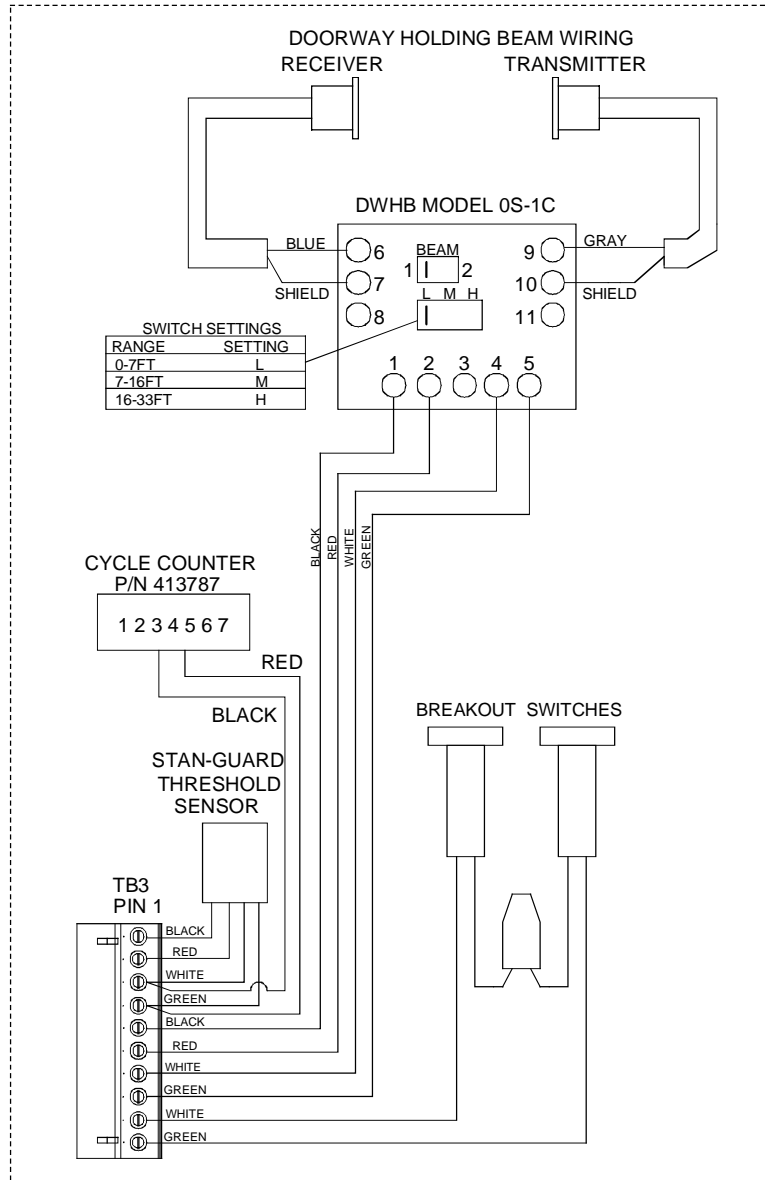

DETAIL A: TB3 CONNECTIONS

DGMCB02\_2

203728

Rev. B, 8/28/00

Page 12 of 18

© 2000, THE STANLEY WORKS. ALL RIGHTS RESERVED.

## Attachment 2

### System Wiring Diagram—5000-Series Sliders

(Sheet 1 of 2)

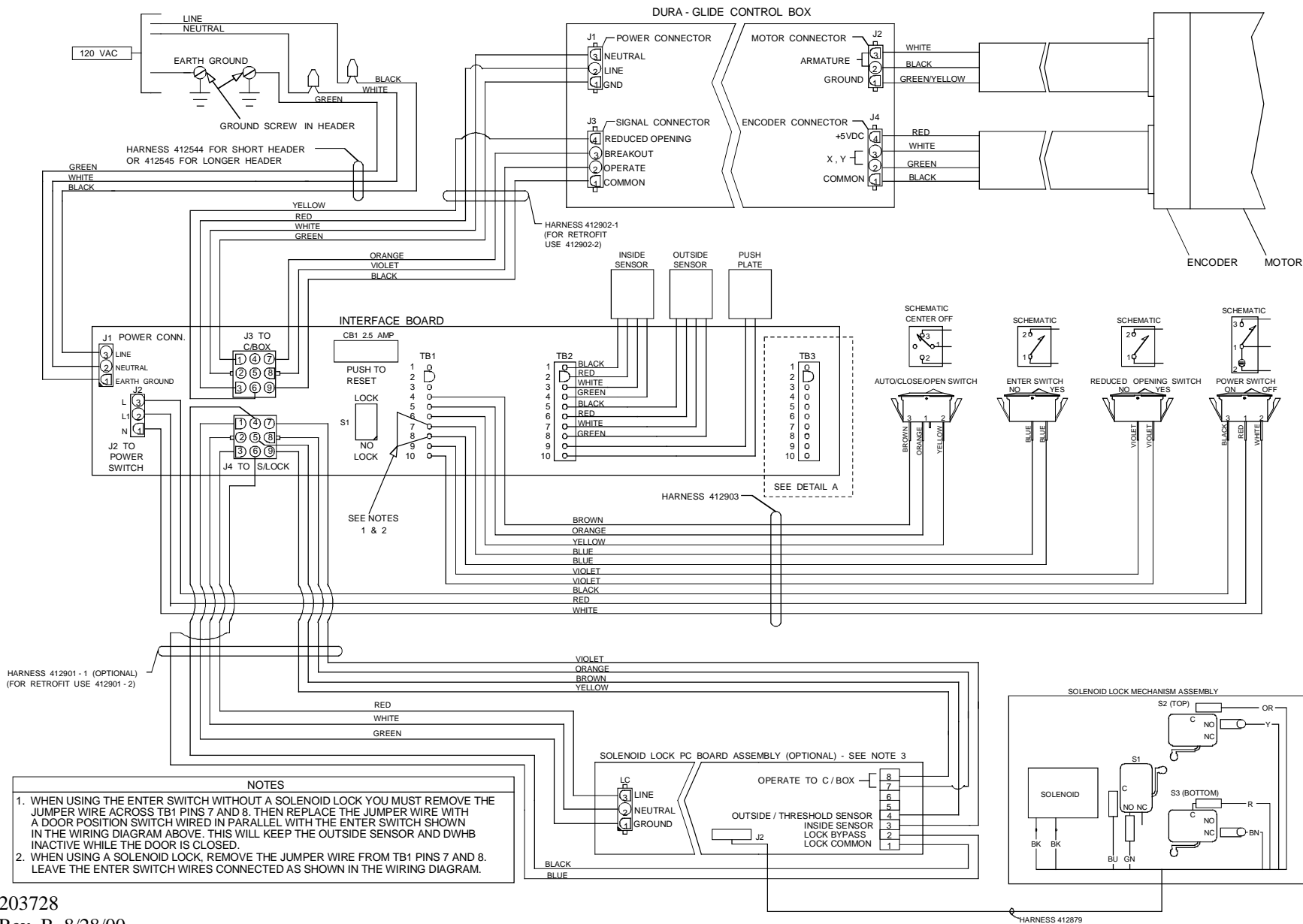

203728

Rev. B, 8/28/00

Page 13 of 18

© 2000, THE STANLEY WORKS. ALL RIGHTS RESERVED.

DGMCB01\_1

## Attachment 2 System Wiring Diagram—5000-Series Sliders

(Sheet 2 of 2)

DOORWAY HOLDING BEAM WIRING (OPTIONAL)

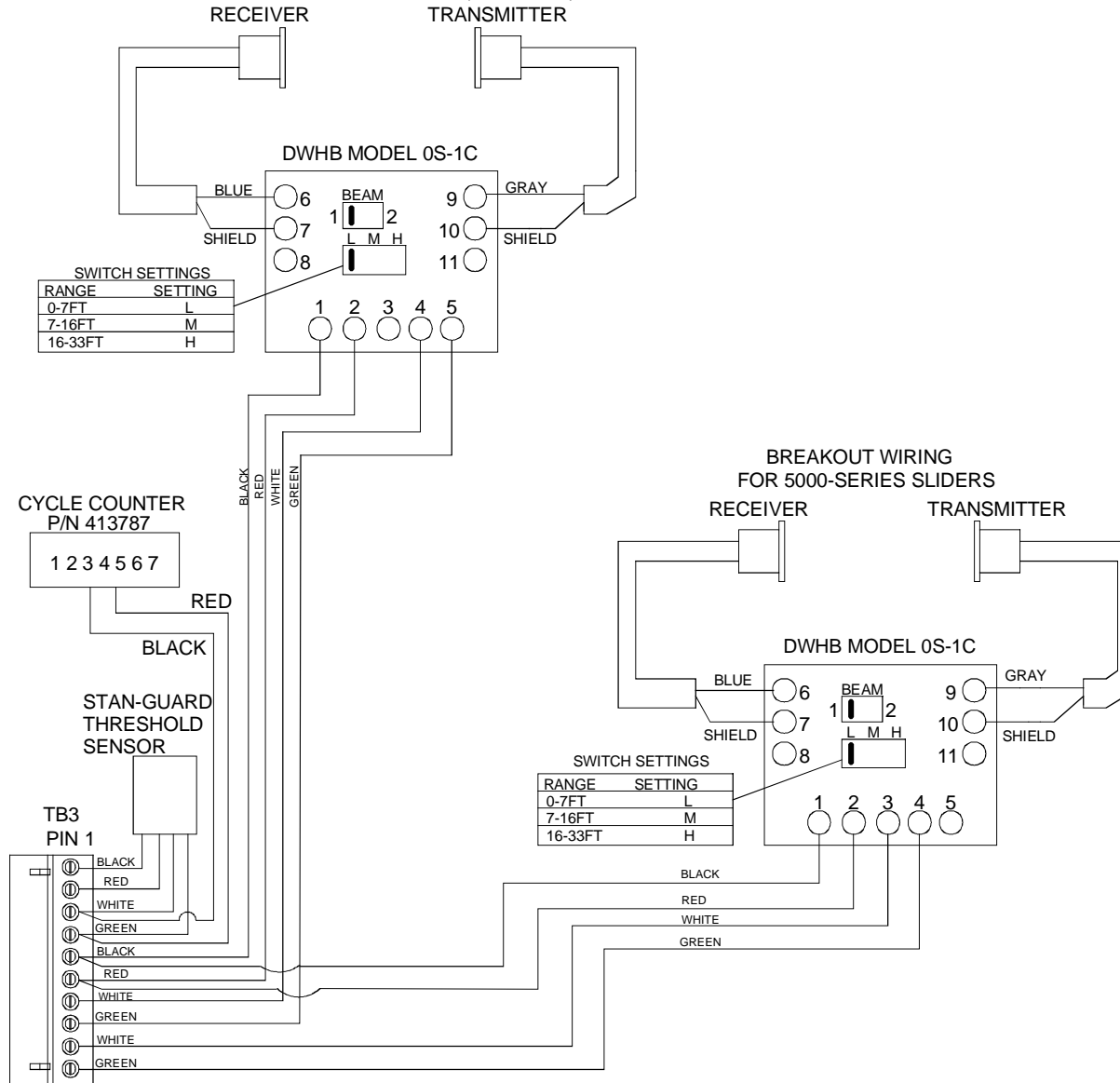

203728

Rev. B, 8/28/00

Page 14 of 18

© 2000, THE STANLEY WORKS. ALL RIGHTS RESERVED.

### DETAIL A: TB3 CONNECTIONS

DGMCB01\_2

**Attachment 3**  
**Interface Board Controls and Indicators**  
 (Sheet 1 of 1)

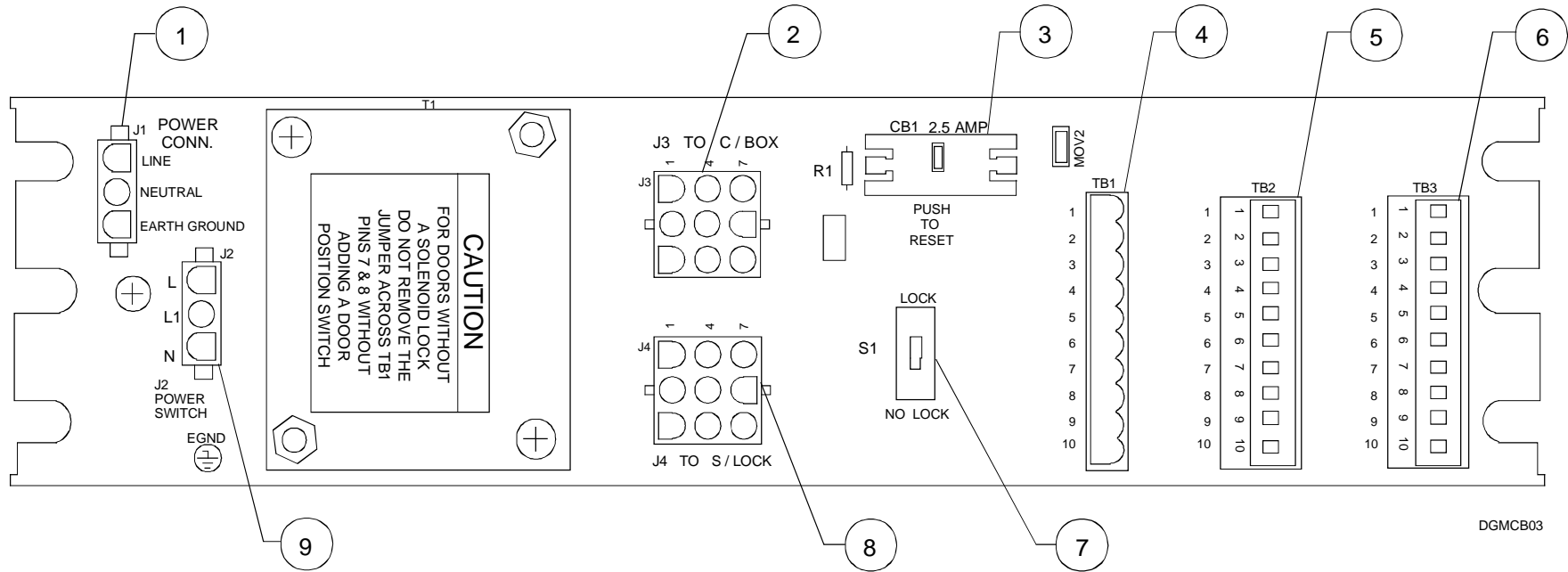

ITEM	CONTROL/ INDICATOR	DESCRIPTION
1	Connector J1	Incoming power connection.
2	Connector J3	Connection to control box power and signal connectors.
3	Circuit Breaker CB1	Push to reset 2.5-amp circuit breaker.
4	Terminal Block TB1	Connection to "AUTO/CLOSE/OPEN" switch, "ENTER" switch, and "REDUCED OPENING" switch.
5	Terminal Block TB2	Connection to inside sensor, outside sensor, and push plate.
6	Terminal Block TB3	Connection to cycle counter, threshold sensor, breakout wiring, and optional doorway holding beam wiring.
7	LOCK/NO LOCK Switch S1	Two-position slide switch used to configure door with or without lock.
8	Connector J4	Connection to optional solenoid lock PC board assembly.
9	Connector J2	Connection to "POWER ON/OFF" switch.

203728

Rev. B, 8/28/00

Page 15 of 18

© 2000, THE STANLEY WORKS. ALL RIGHTS RESERVED.



# Attachment 4

## Microprocessor Control Box Controls and Indicators

(Sheet 1 of 3)

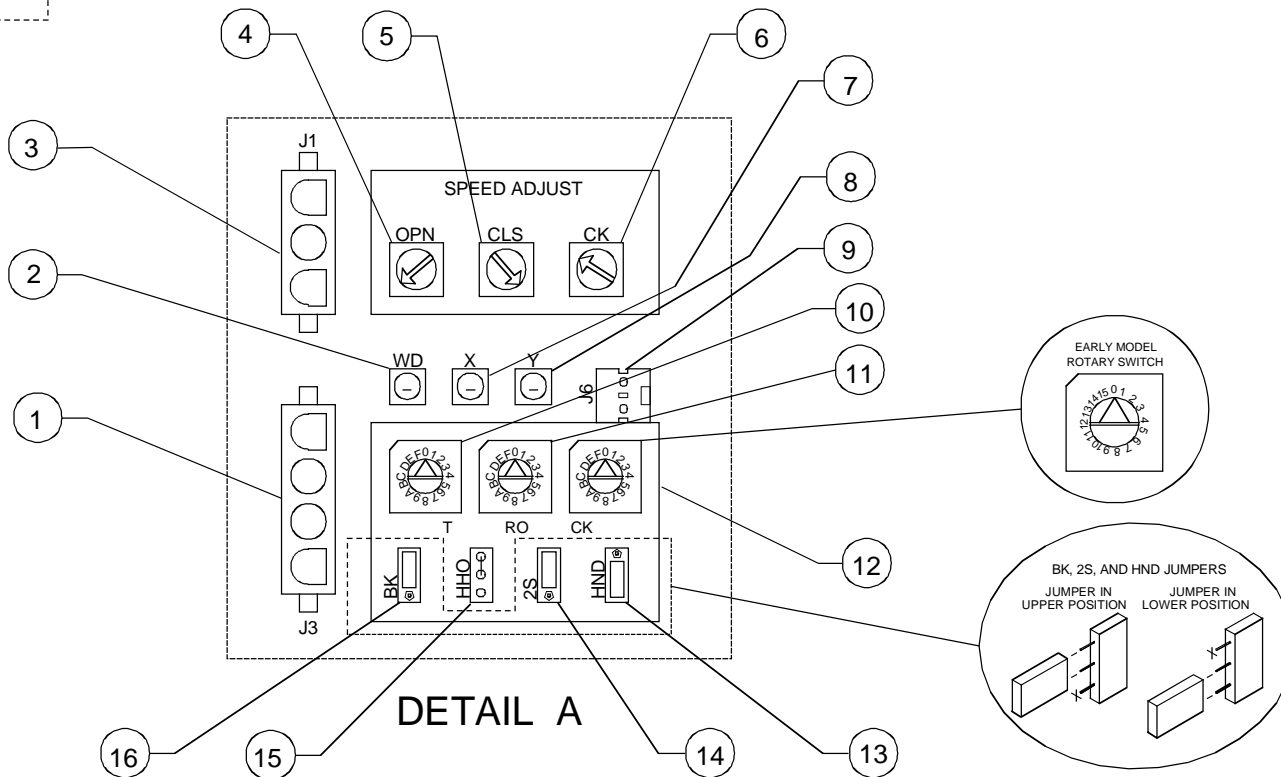
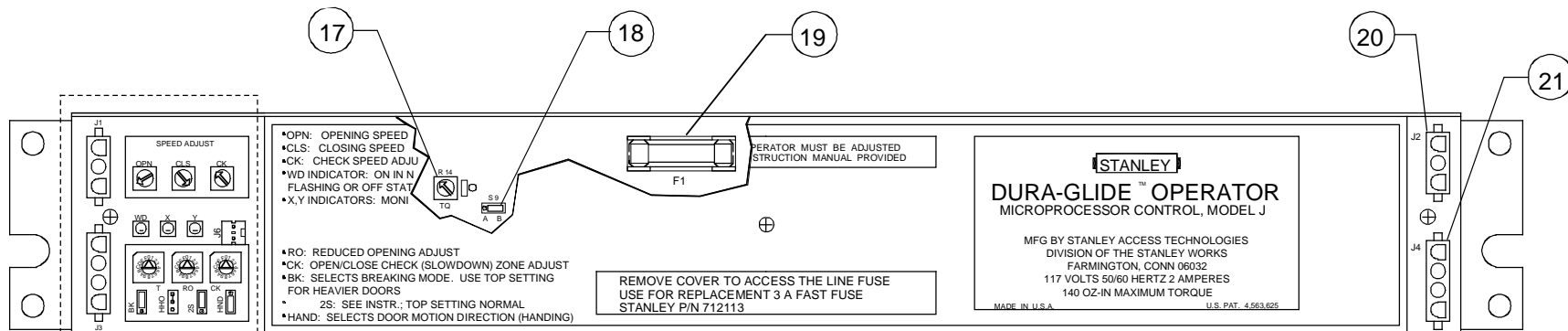

**Attachment 4**  
**Microprocessor Control Box Controls and Indicators**  
(Sheet 2 of 3)

ITEM	CONTROL/ INDICATOR	DESCRIPTION
1	Connector J3	Signal connection to interface board connector J3.
2	WD (Watchdog) LED	Illuminates steady red when the power is applied and the control box is functioning properly. Flashes when a microprocessor error has been detected. When not lit, indicates no power is applied, fuse has failed, or control box has an internal problem.
3	Connector J1	Power connection to interface board connector J3.
4	Open Speed Potentiometer	Adjusts door opening speed. Clockwise rotation increases door-opening speed. Counterclockwise rotation decreases door-opening speed.
5	Close Speed Potentiometer	Adjusts door closing speed. Clockwise rotation increases door-closing speed. Counterclockwise rotation decreases door-closing speed.
6	Check Speed Potentiometer	Adjusts speed of door in both the open and close check zones. Clockwise rotation increases check speed. Counterclockwise rotation decreases check speed.
7	X LED	Red LED indicates status of the encoder. Flashes when door is in motion to indicate properly functioning encoder. Flashing rate corresponds to door opening/closing speed.
8	Y LED	Red LED indicates status of the encoder. Flashes when door is in motion to indicate properly functioning encoder. Flashing rate corresponds to door opening/closing speed.
9	Side Screen Safety Sensor Jack	Permits connection of side screen safety sensor.
10	Time Delay Switch	Fixed at the "1" position. Do not attempt to change setting.
11	Reduced Opening Switch	Adjusts size of opening from 10 to 96 inches. Higher letters provide increased opening size. Lower letters provide smaller opening size. Refer To Table 2 for switch settings and reduced opening sizes.
12	Check Size Switch	Adjusts size of check zone from 3 to 18 inches. Higher letters provide increased check size. Lower letters provide smaller check size. Refer To Table 1 for switch settings and check sizes.
13	Handing Jumper	Controls door handing. Place jumper in lower position for right hand and bi-part sliders. Place jumper in upper position for left hand sliders.
14	Normal/2S Logic Jumper	Controls normal and 2S logic operation. In 2S logic mode, the doors open when an operate signal is received and close when a second operate signal is received. Place jumper in lower position to enable 2S logic operation. Place jumper in upper position for normal operation.
15	Handicap Hold Open Jumper	The handicap hold open feature was removed in 1993.

**Attachment 4**  
**Microprocessor Control Box Controls and Indicators**  
(Sheet 3 of 3)

<b>ITEM</b>	<b>CONTROL/INDICATOR</b>	<b>DESCRIPTION</b>
16	Brake Mode Jumper	Controls the transition from full speed to check speed. Place jumper in lower position for minimum braking. Place jumper in upper position for maximum braking. Heavier doors require maximum braking.
17	Torque Potentiometer	Adjusts door-opening torque. Clockwise rotation increases opening torque. Counterclockwise rotation decreases opening torque.
18	S9 Jumper	Applicable on heavy-duty control boxes only. Controls selection of either maximum opening torque or proportionally adjusted opening torque. Place jumper to position A to provide maximum opening force regardless of the torque potentiometer setting. (This is advantageous for heavy doors.) Place jumper to position B to provide opening force control using the torque potentiometer.
19	Fuse	3-amp slow-blow fuse
20	Connector J2	Motor connection
21	Connector J4	Encoder connection