

SWINGMASTER® MP

IK-A (Concealed) & IKS-A (Surface Applied); Bottom Load & Fire Door Swing Door Operator

Installation, Adjustment and Troubleshooting Manual

Applications:

- All Pedestrian Applications
- Colleges/Schools
- Light Industry
- Medical Centers
- Office Buildings
- Pharmacies
- Residential
- Shopping Malls
- Specialty
- Fire Doors
- Concealed or Surface Mounted

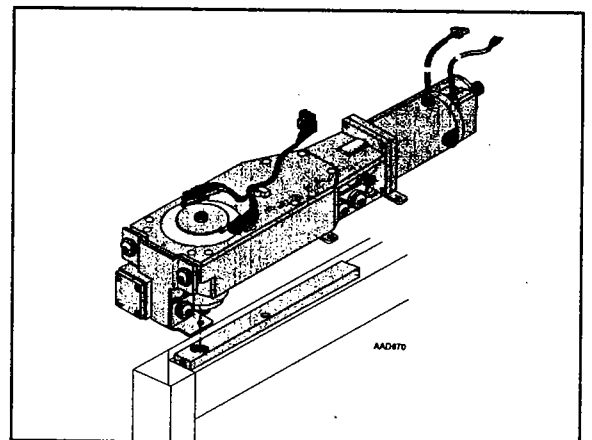
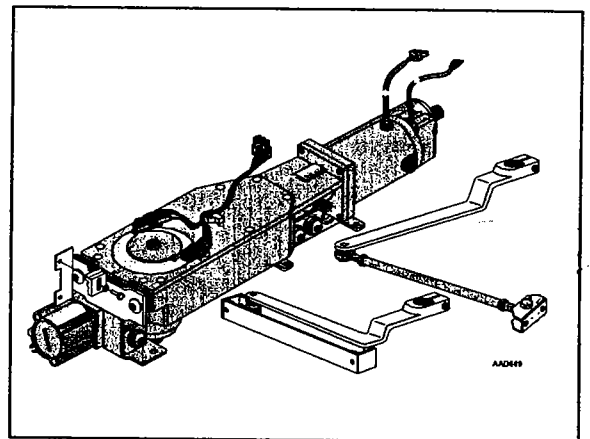

Complies with ANSI/BHMA A156.10-1999 standards for power operated pedestrian doors. UL 325 Listed

Table of Contents

Table of Contents	2
Important Information	3
Technical Specifications	3

Getting Started

Introduction	4
How The Swingmaster Works	4
Part Identification & Options	6-9
Pre-Installation Questions	10
Installation Overview	11
Installation Examples	12
Fastening Requirements	13
Tools and Test Equipment	13

Installation

Concealed	14-20
Surface Mount	21-27
Bottom Load	28-29
Fire Door	30-32
Double Doors	33-37

Adjustments And Troubleshooting

Electrical Connections	38
Wiring The CUP Control Unit	39
Adjusting The CUP	40
Using The PMD	41-45
Wiring Options	46-48
Sign Placement	49
Troubleshooting	50-52

Reference

ANSI / BHMA A156.10 - 1999 Reference	53-54
Door Handing / Hinging	55
Frequently Asked Questions	56
Planned Maintenance Checklist	57
Notes	58
Parts List	59
Bulletins and Revisions	Back Cover

Important Information

Important notice!

To avoid bodily injury, material damage and malfunction of the product, the instructions contained in this manual must be strictly observed during installation, adjustment, repairs and service etc. Only Besam trained experts should be allowed to carry out these operations.

Radio and television reception

This equipment generates and uses radio frequency energy and if not installed and used properly, that is, in strict accordance with the manufacturer's instructions, may cause interference to radio and television reception. It has been designed to comply with the emission limits in accordance with EN 50081-1 (US market FCC Part 15) which are designed to provide reasonable protection against such interference in a residential installation. However, there is no guarantee that interference will not occur in a particular installation. If this equipment does cause interference to radio or television reception, which can be determined by turning the equipment off and on, the user is encouraged to try to correct the interference by one or more of the following measures:

- Re-orient the receiving antenna.
- Relocate the receiver with respect to the equipment.
- Move the receiver away from the equipment.
- Plug the receiver into a different outlet so that equipment and receiver are on different branch circuits.

If necessary, the user should consult the dealer or an experienced radio/television technician for additional suggestions.

Note!

Instructions, design, specifications and illustrations which are contained in this manual are not binding. Rights reserved for changes without previous notice.

Environment

This operator may be equipped with batteries containing materials which are hazardous to the environment. Remove the batteries from the operator before it is scrapped. The batteries must be disposed of safely.

Technical Specifications

Power supply 120 V AC $\pm 10\%$, 60 Hz fuse 10 A

Note!

A switch with clearly marked off-position, having a contact separation of at least 1/8" in all poles, must be incorporated in the Mains wiring.

Power consumption max. 200 W

Auxiliary voltage 18 V DC, 300 mA
24 V DC, 615 mA

Control fuse F1 2 Amp

Motor fuse F2 10 Amp

Recommended max. door weight:
Concealed (IK-A) 220 lb for door leaf width
max. 55" *

Recommended max. door weight:
Surface-Mount (IKS-A) 990 lb for door leaf width < 39"
770 lb for door leaf width $\geq 39''$
and < 47"

550 lb for door leaf width $\geq 47''$
and < 55" *

Opening time (0° – 80°) variable between 2 – 6 seconds

Closing time (90° – 10°) variable between 2 – 6 seconds

Hold open time 0-60 seconds

Ambient temperature -5° F to 113° F

To be installed internally or externally with suitable weather protection.

* Note: Building codes may not permit doors wider than 48".

Introduction

This manual contains the necessary details and instructions for the installation, maintenance and service of the Besam swing door operator, Swingmaster MP, a universal electro-mechanical operator suitable for all types of external and internal swing doors.

The Swingmaster MP Concealed (IK-A) is designed to be integrated in the complete jamb and door assembly. It is self-supporting and suitable for single or double doors fitted with center pivots.

The Swingmaster MP Surface Mount (IKS-A) can be mounted on either side of the door header for pull or push action, and is suitable for single or double doors fitted with butt hinges, offset or center pivots.

A Besam Swingmaster MP swing door operator ensures all-around safety. The operator can be combined with the full range of Besam safety units, such as Visionpulse-S presence sensors and microwave motion detectors.

How The Swingmaster Works

The Swingmaster uses a DC motor and gear-reduction system (the drive unit, or operator) to drive an arm system which opens the door. Closing power is provided by the motor and a coil spring. An electronic control unit uses a motor-mounted revolution counter to control the door's movement.

Opening

When an opening signal is received by the control unit, the door is opened at the Swingmaster's high speed. Before the door is fully open, it slows to low speed. The motor stops when the selected door-opening angle has been reached. The open position is held by the motor.

If the "Push Reactivation" option (default) is selected, the door, when opened by hand a short distance (about 3/4"), will continue to open automatically to the preset fully-open position. When the preset "Push Reactivation" hold-open time has elapsed, the door will close automatically.

If "Push Reactivation" is not selected, the door, when opened by hand, will close immediately once the door is released. In this case, the Swingmaster acts only as a door closer.

Closing

When the hold-open time has run out, the Swingmaster will close the door automatically, using either spring and motor force, or spring force only with the motor acting as a brake. The door will slow to low speed before it reaches the fully closed position. The door is kept closed (the 'zero-position') by spring power and with additional motor force, if so selected. Using the PMD programming module, you can set the door to close by spring force only.

Safety functions integrated in the Swingmaster

Opening

If the door is obstructed while opening, it will immediately stop. After 5 seconds, the door will revert to the closed position.

Closing

If "Push Reactivation" is selected, a door that is obstructed while closing will revert to the open position. When the selected hold open time has elapsed, the door will try to close again.

If "Push Reactivation" is not selected, a door that is obstructed while closing will stop. When the obstruction is removed, the door will continue to close.

Panic opening

The operator permits the door to be manually opened in the opposite direction to the door's normal automatic opening direction. If the door is panic-opened, the automatic function is disengaged. The door will close with controlled spring power only.

Safety functions with sensors

Safety sensors, such as the Besam Visionpulse, can achieve an even higher degree of safety.

Cam and Switches

The cam and switch assembly eases the manual opening of the door in either direction (panic or normal), and controls the door closing in the event of power failure.

The switches and cam are mounted on the top end of the drive shaft. They are shown here with the drive shaft in 0-position (closed door).

Note: The cam and switches are factory mounted and no further adjustment is needed.

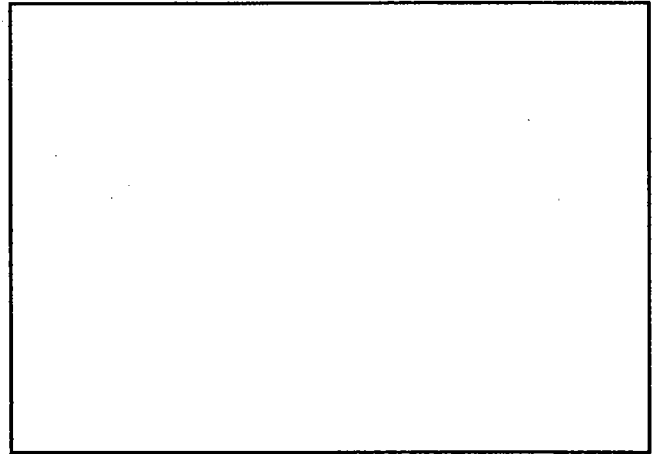

Types of installation

The drive unit may be installed in two types of header (casing): Side Load and Bottom Load.

Side Load is the standard type of header. The drive unit is installed in the header from the side.

Bottom Load is used for special applications where space may be tight (e.g., where the finished ceiling is flush with the bottom of the header). The drive unit is installed in the header from the bottom.

In addition to the above, the drive unit and header may be positioned in two ways with respect to the door: concealed and surface applied.

Concealed means that the drive unit and header are placed between the door jambs with the door, and are concealed in the wall. The operator drive shaft becomes one of the door pivots.

Surface Applied means that the drive unit and header are mounted on the surface of the wall, and an external arm system is used to operate the door. A surface applied header is typically 3" longer than the concealed, in order to attach easily to the jambs.

A surface applied Swingmaster drive unit requires further rack gear travel and thus has an extension to the rack gear shaft - see illustration at right.

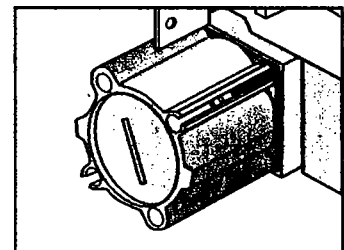

Part Identification & Options

Swingmaster MP Surface Mount (IKS-A) – Side Load

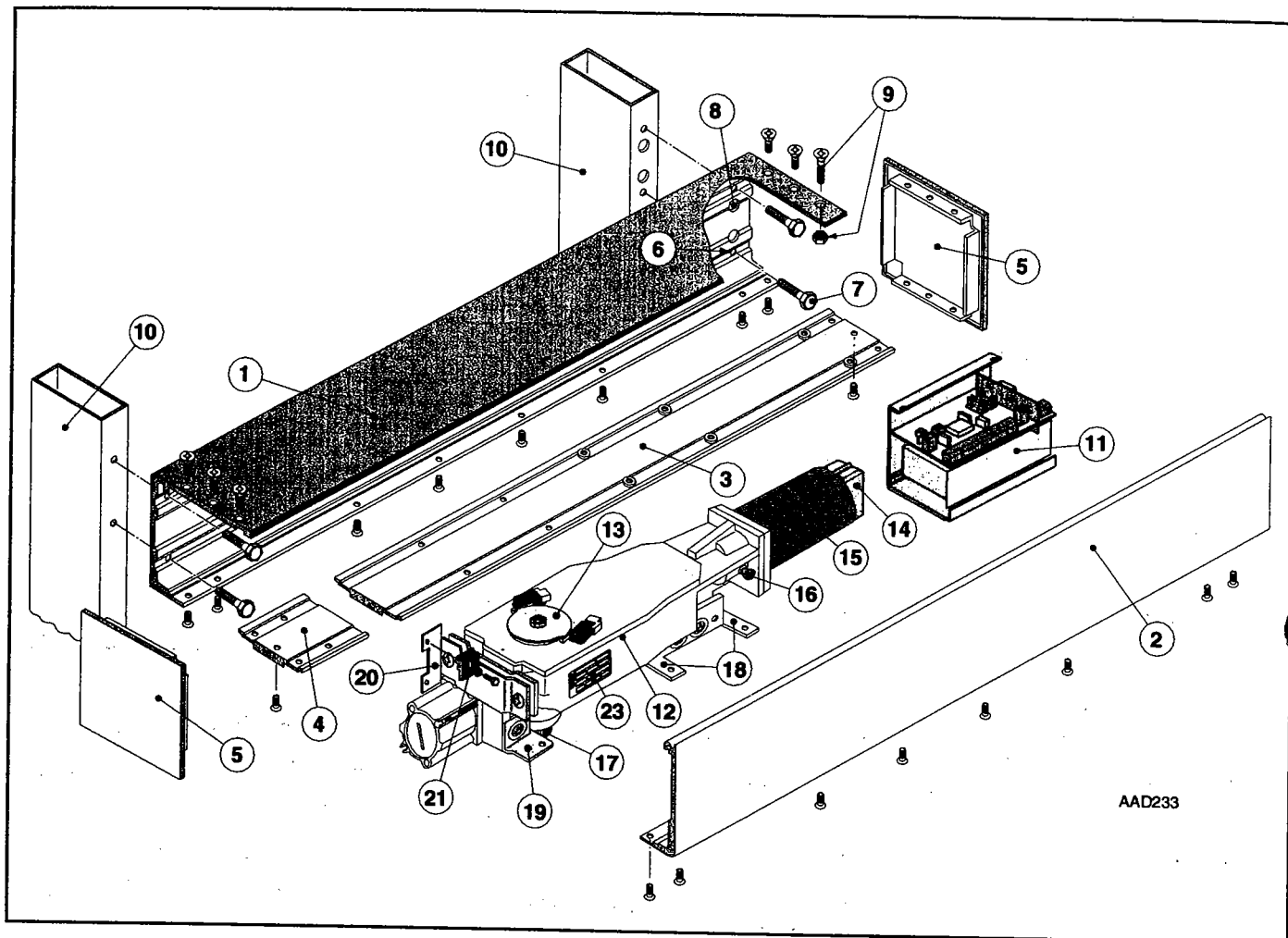

- | | | | |
|------|---------------------------|------|---------------------------|
| (1) | Header | (12) | Drive Unit |
| (2) | Cover | (13) | Cam and Switches |
| (3) | Long Center Panel | (14) | Revolution Counter |
| (4) | Short Center Panel | (15) | Motor |
| (5) | End Caps (Two) | (16) | Spindle Lock Screw |
| (6) | Header Mounting Holes (4) | (17) | Drive Spindle |
| (7) | Mounting Bolts (4) | (18) | Rear Mount |
| (8) | Cable Holes (2) | (19) | Front Mount |
| (9) | Ground Bolt (1) | (20) | Support Bracket (Surface) |
| (10) | Jamb / Wall | (21) | Clamp Plate (Surface) |
| (11) | CUP Control Unit | (23) | Label |

Part Identification & Options

Swingmaster MP Concealed Mount (IK-A) – Side Load

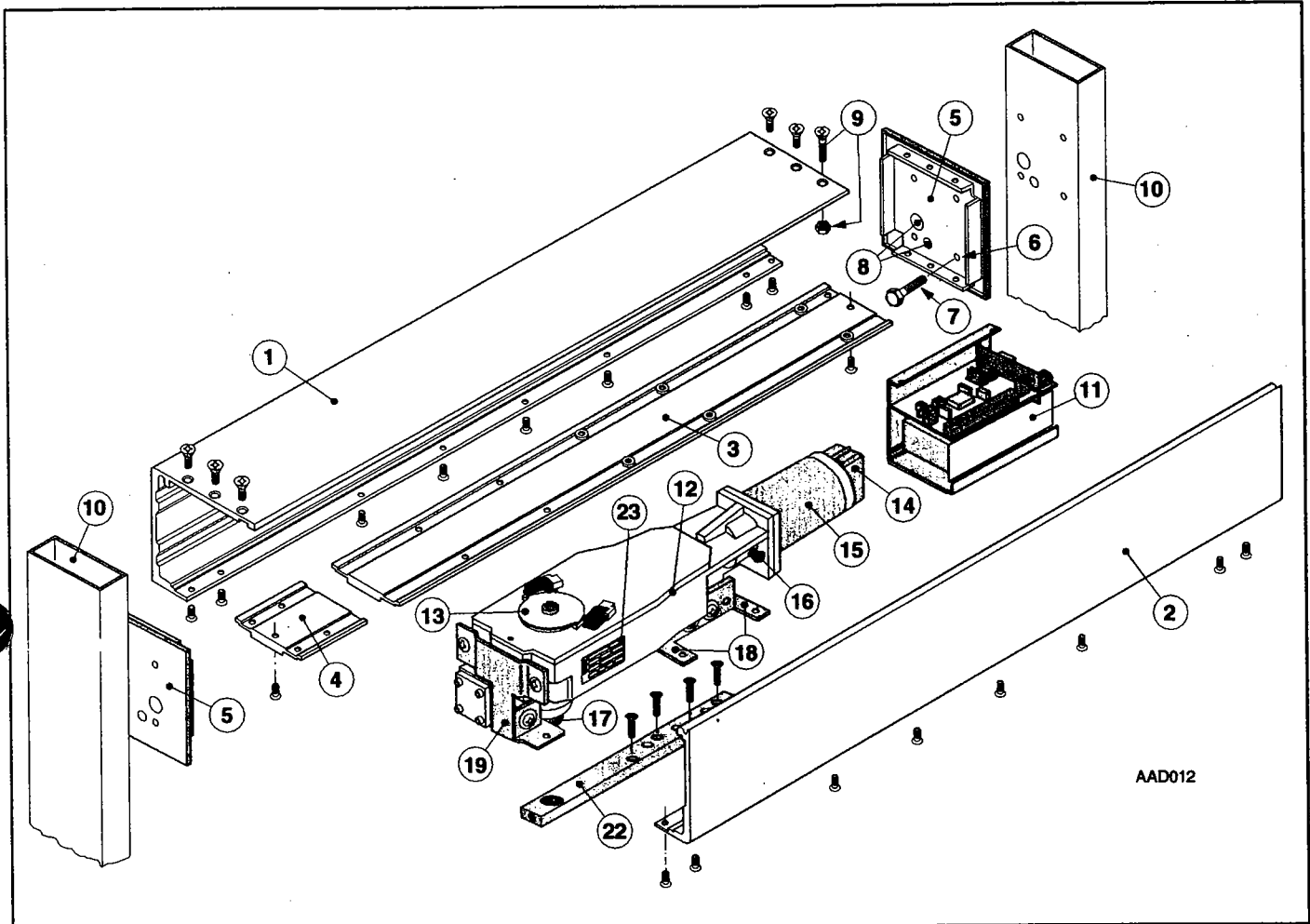

AAD012

- | | |
|-------------------------------|----------------------------|
| (1) Header | (12) Drive Unit |
| (2) Cover | (13) Cam and Switches |
| (3) Long Center Panel | (14) Revolution Counter |
| (4) Short Center Panel | (15) Motor |
| (5) End Caps (Two) | (16) Spindle Lock Screw |
| (6) Header Mounting Holes (8) | (17) Drive Spindle |
| (7) Mounting Bolts (8) | (18) Rear Mount |
| (8) Cable Holes(2) | (19) Front Mount |
| (9) Ground Bolt (1) | (22) Drive Arm (Concealed) |
| (10) Jamb Tubes (Door Frame) | (23) Label |
| (11) CUP Control Unit | |

Part Identification & Options

Arms

Note: Only one arm is required per operator.

The Swingmaster MP can be equipped with three kinds of arm: a pushing arm that pushes the door open, a pulling arm that pulls the door open, and a concealed arm that swings the door in either direction.

Pushing arm: NAS

- Clr: 30-06-102
- Blk: 30-06-217

The NAS is used when installing the Swingmaster on the opposite side of the wall from the direction in which the door opens.

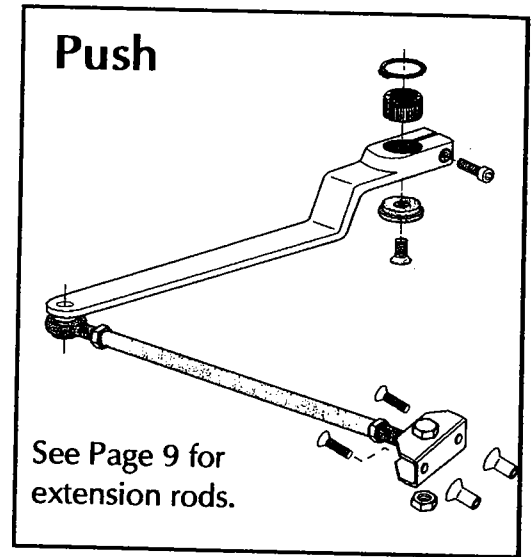

Pulling arm: PAS

- Right Hand, Clr: 30-06-103
- Right Hand, Blk: 30-06-226
- Left Hand, Clr: 30-06-104
- Left Hand, Blk: 30-06-215
- 20" Track - Clr: 30-06-241
- Blk: 30-06-242
- 24" Track - Clr: 30-06-243
- Blk: 30-06-244

The PAS is used when installing the Swingmaster on the same side of the wall on which the door opens.

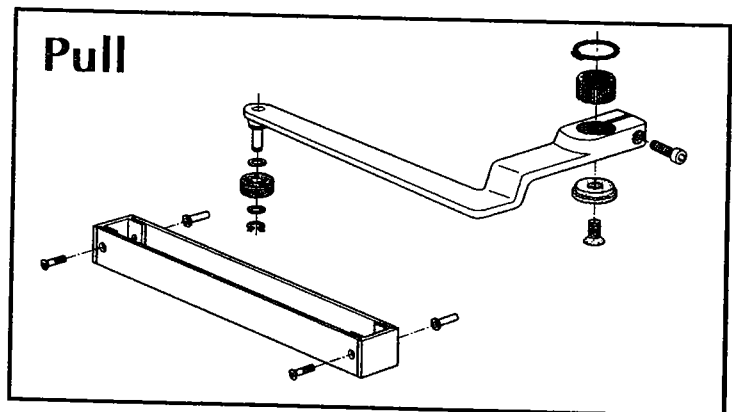

Concealed Arm:

- Clr: 30-06-101

The concealed arm is used on center pivot doors in an overhead concealed (OHC) application.

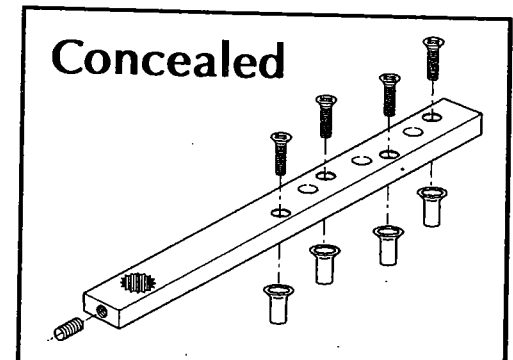

Spacer Kit:

- Clr: 50-15-114

The spacer kit is used with the concealed arm only. It adds 3/8" height to the concealed arm, and is useful for hollow-top / aluminum extrusion doors.

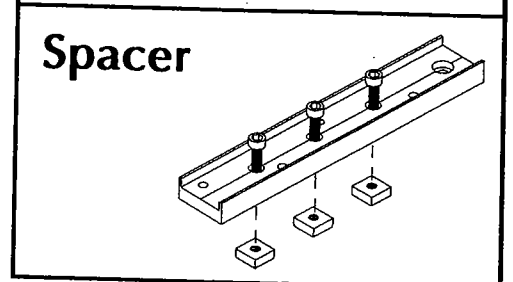

Part Identification & Options

Options

Push Plates come in three shapes (Round, Square and Narrow), and in normal or remote switch configuration.

Push Plates:

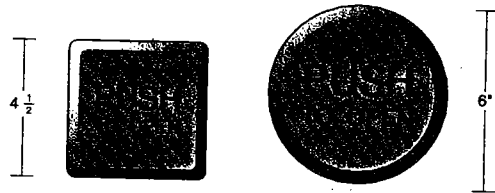

P/N: US02-0153-02
 P/N: US02-0153-04
 P/N: 75-02-100
 P/N: 75-02-104

Square: "Push To Open"
 Square: Blank
 Round: "Push To Open"
 Round: Blank

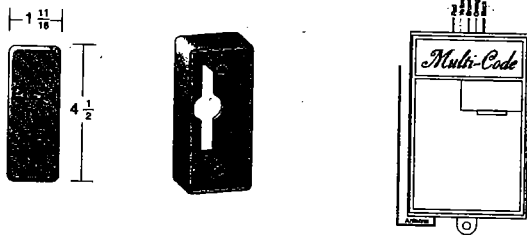

P/N: 75-02-281
 P/N: 75-21-002

Narrow: "Push To Open"
 Installation box for Narrow plates

Remote Push Plates (RF):

P/N: 75-02-269
 P/N: 75-02-273
 P/N: 75-02-271

Narrow: "Push To Open"
 Round: "Push To Open"

Remote Receiver

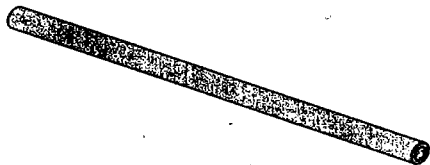

Push Arm Extension Rods:

P/N: 30-06-201
 P/N: 30-06-112
 P/N: 30-06-110
 P/N: 30-06-113
 P/N: 30-06-107
 P/N: 30-06-114
 P/N: 30-06-109
 P/N: 30-06-115

5" - 6" Reveal - Clear
 5" - 6" Reveal - Black
 7" - 8" Reveal - Clear
 7" - 8" Reveal - Black
 9" - 10" Reveal - Clear
 9" - 10" Reveal - Black
 11" - 12" Reveal - Clear
 11" - 12" Reveal - Black

Surface Applied Drive Shaft Extension Kits:

Note: For overhead concealed extension, contact factory.

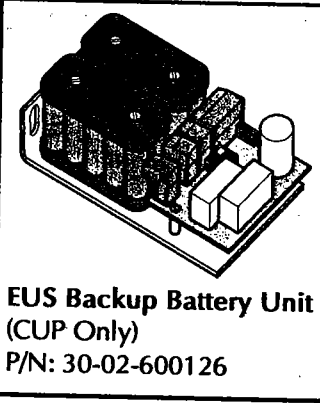
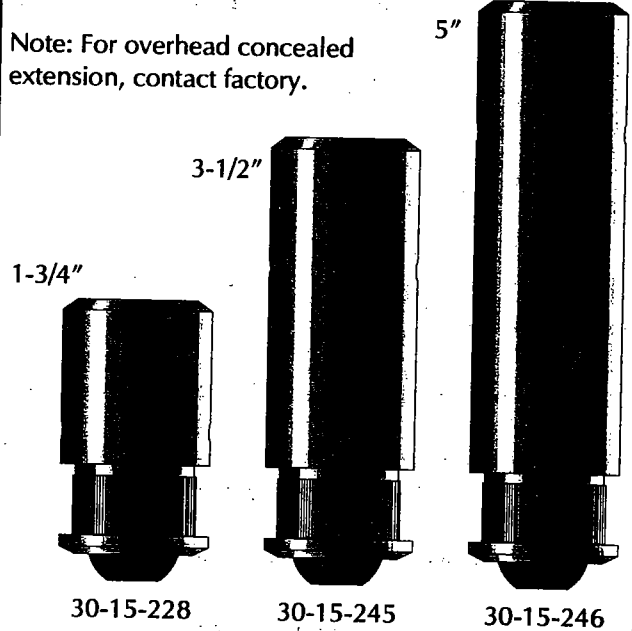

EUS Backup Battery Unit
 (CUP Only)
 P/N: 30-02-600126

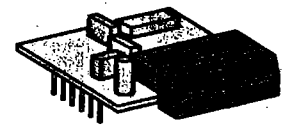

EXS expansion board (for CUP control units only). See page 48 for features and a full description.

P/N: 30-02-655630

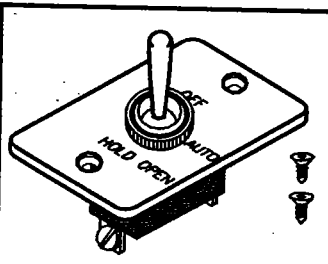

3 Position Switch (SPDT)
 P/N: 75-15-310 - Clear
 P/N: 75-15-311 - Black

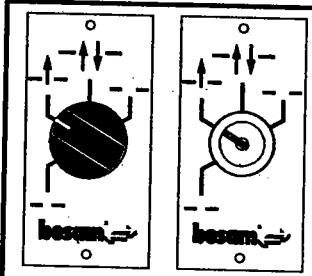

4 Pos. Switch
 - Knob P/N: 75-15-100 - Clr
 P/N: 75-15-101 - Blk
 - Key P/N: 75-15-105 - Clr
 P/N: 75-15-106 - Blk

Pre-Installation Questions

This section will help you to determine the appropriate Swingmaster configuration for your doors.

A. Is this installation a pair of inswing or outswing doors?



B. Is this installation a pair of dual egress doors?

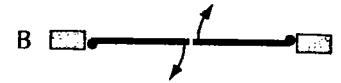

C. Is this installation a pair of inswing or outswing doors with an overlapping astragal?



If the answer to A, B or C is yes, please see pages 33-37 for information on door pairs and matching height installations.

D. What is the handing of the door? (See page 55.)



Right Hand Out



Left Hand In



Left Hand Out



Right Hand In

Interior

Exterior

E. What type of arm system is required?

If the door opens in a direction opposite to the side of the wall where you wish to install the drive unit, you will need a Push/Swing (NAS) arm. If the door opens on the same side of the wall where you wish to install the drive unit, you will need a Pull/Swing (PAS) arm. If the unit is concealed, you will need the concealed arm.

F. (Surface Applied) What is the reveal of the installation, in inches? Is it within the arm's capability? (See pages 24 & 25.)

G. (Surface Applied) What type of hinges are on the door? (Center Pivots, Butt Hinge, Offset Pivot.)
Note: The Swingmaster is not designed to be applied to balance doors.

H. Where will power and signal wires enter the operator housing? (Back, End cover.)

I. What kind of operator housing do you have (side load or bottom load, concealed or surface?)

General Tips / Safety Concerns

For enhanced security and vandalism protection, always mount the operator access in the interior of a building.

Make sure that the power is off before installing.

Make sure that the door leaf and the wall are properly reinforced at the installation points. See page 12-13 for specifications and suggestions.

Inspect the door hinges before installation to ensure that they are in good repair.

Installation Overview

Surface Applied and Concealed Applications

This is only a summary of the installation process. See the rest of this manual for detailed information.

- 1: Start by determining the answers to the pre-installation questions on page 10.
- 2: Establish installation height.
- 2b: Surface applied: locate header horizontally above door so that the center line of spindle to center line of hinge dimension is correct. (3.75")
- 3: Install the header.
- 4: Mount the drive unit.
- 5: Attach the CUP control unit so that the PC board is facing up. Do not install upside down!
- 6: **Surface applied:** Attach the arm shoe to the door. **Concealed:** Mount drive arm to shaft.
- 7: **Surface applied:** Mount the rest of the drive arm. **Concealed:** Mount/hang the door
- 8: Complete all electrical connections to other operators or optional equipment.
- 9: Adjust the control unit for optimal and safe performance, in accordance with ANSI.BHMA A156.10 specifications.
- 10: Apply safety signage to the door(s).
- 11: Train facility manager in operation
- 12: Explain to the facility manager the daily safety check described in the owner's manual, and leave a copy of the owner's manual with the facility manager.

Installation Examples

- A Steel reinforcement or rivnut
- B Steel reinforcement
- C Expansion-shell bolt
- D Wood reinforcement
- E Steel beam

1 Aluminum profile system

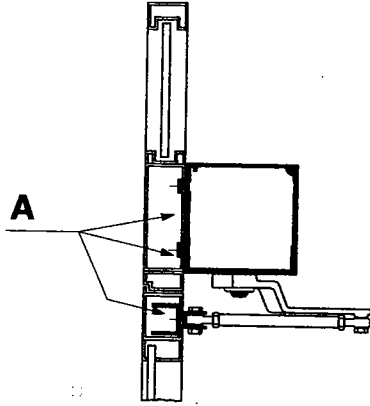

2 Plasterboard wall

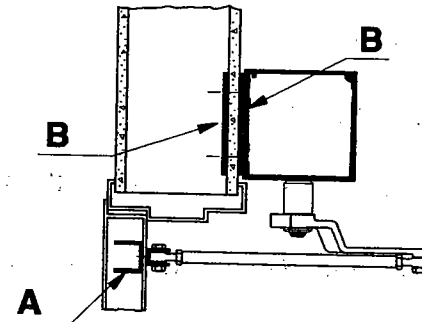

3 Reinforced concrete wall and brick wall

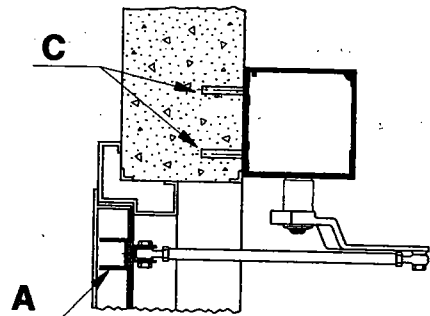

4 Plasterboard wall

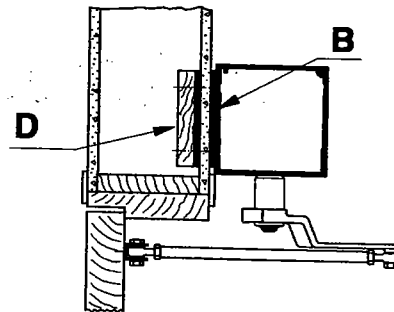

5 Reinforced concrete wall

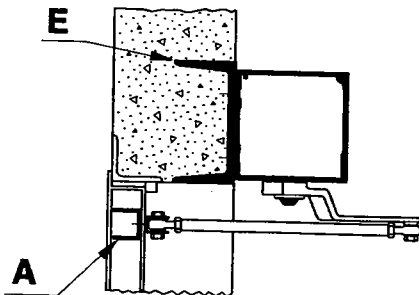

AAB923

Fastening Requirements

Base door / wall material	Minimum anchor / bolt requirement *
Steel	3/16" **
Aluminum	1/4" **
Reinforced concrete	min. 2" from the underside
Wood	2"
Brick wall	Expansion-shell bolt, min. 1/4" x 3 1/2", min. 2" from the underside

* Besam minimum recommended requirements. Building Codes may give different specifications.
** Thin-wall profiles must be reinforced with rivnuts.

Test Equipment

Stopwatch
Force gauge (50 lb force range)
PMD Programming Module
Multimeter

Tools Required

Set of box end wrenches
Carpenter's level
Tape rule
Power drill and set of drill bits
Metric hex key set (6,5,4 mm and 2.5 mm)
Torx (T20)
Center punch
#2 Phillips screwdriver
Flatblade screwdriver (small/med./large)
Wire stripper
Pencil
Torque wrench /w/ metric allen sockets
Additional mounting hardware (not supplied – see recommendations above)
Silicone sealant
Plumb bob

Concealed Installation

The concealed operator (IK-A) is used to control a center-pivot door, with the operator integrated and concealed in the header above the door.

The door can be opened in a direction opposite to normal in an emergency (panic breakout).

A concealed operator can also be installed in the ceiling space above the door (bottom load) or the basement space below the door (mole operator). Such applications may require field engineering of components and hardware.

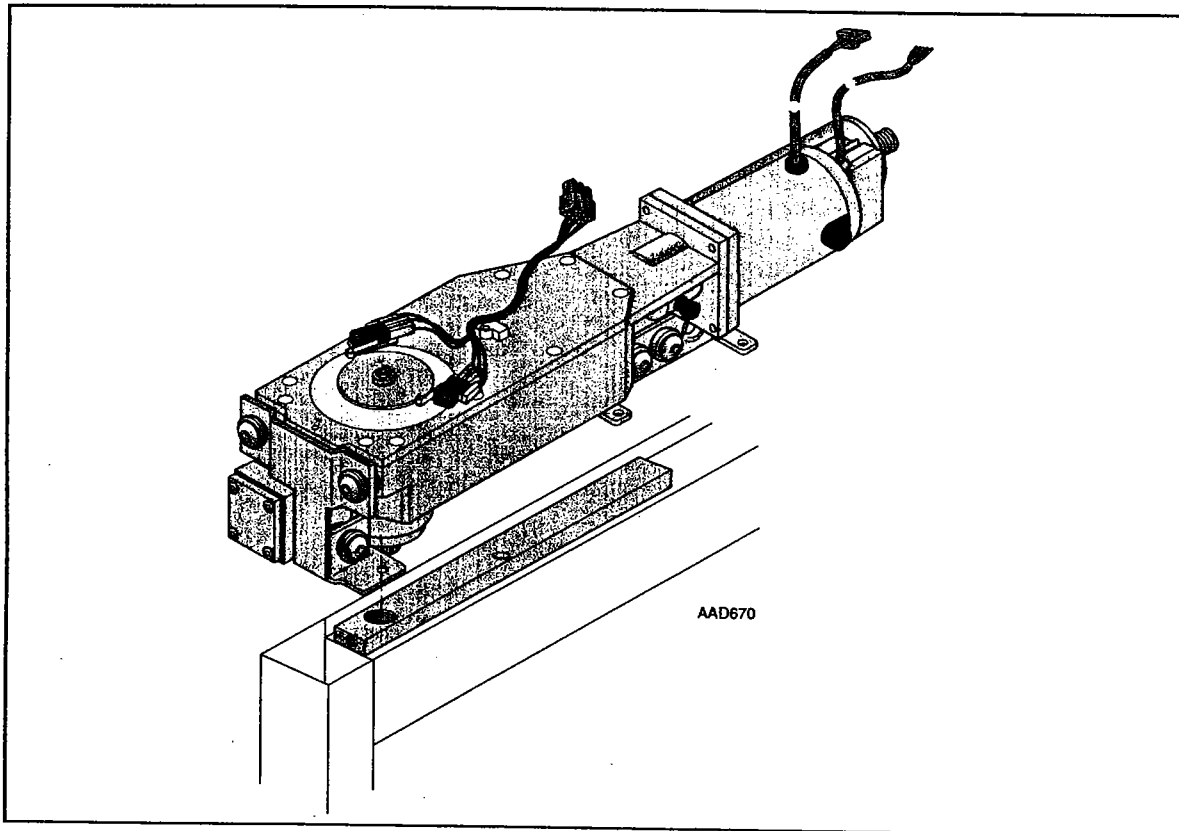

Operator for right-handed door:

Operator for left- and right-handed doors:

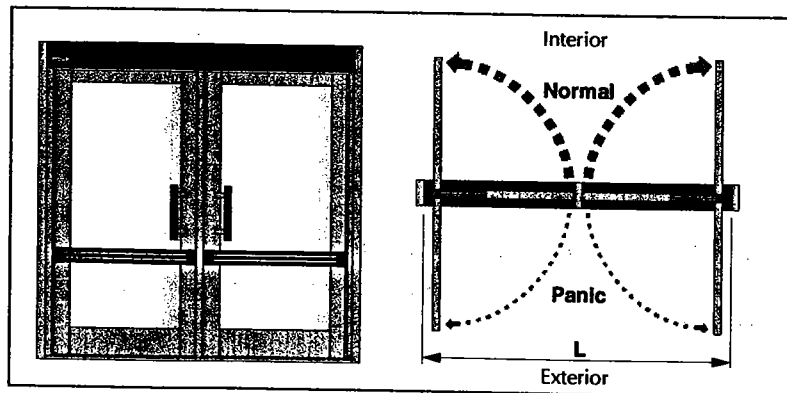
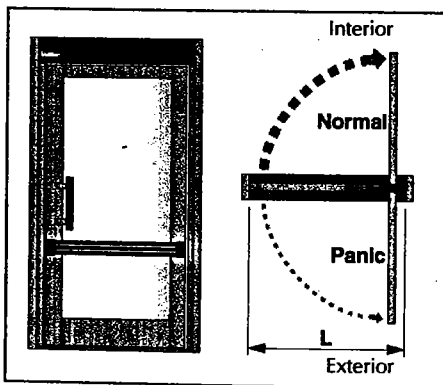

L = Header Length

Concealed Installation

Installation for center pivot doors

FINDING THE PIVOT HEIGHT

LH = Door Opening Height
 DH = Door Height
 X = Pivot Height
 Y = Door Bottom to Receiving Surface of Pivot Socket

1. Measure the height of the door (DH).
2. Measure from the bottom of the door to the receiving surface of the pivot socket (Y). Subtract (Y) from (DH).
3. Add 1/8" to allow for top clearance.
4. Subtract the total from (LH) to obtain the Pivot Height (X).

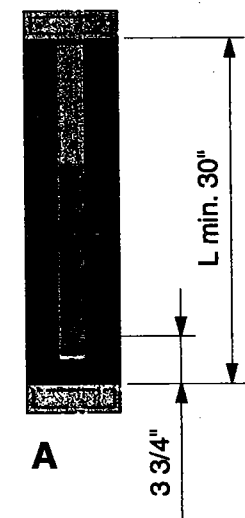
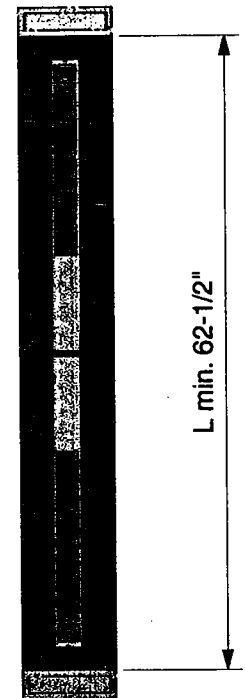
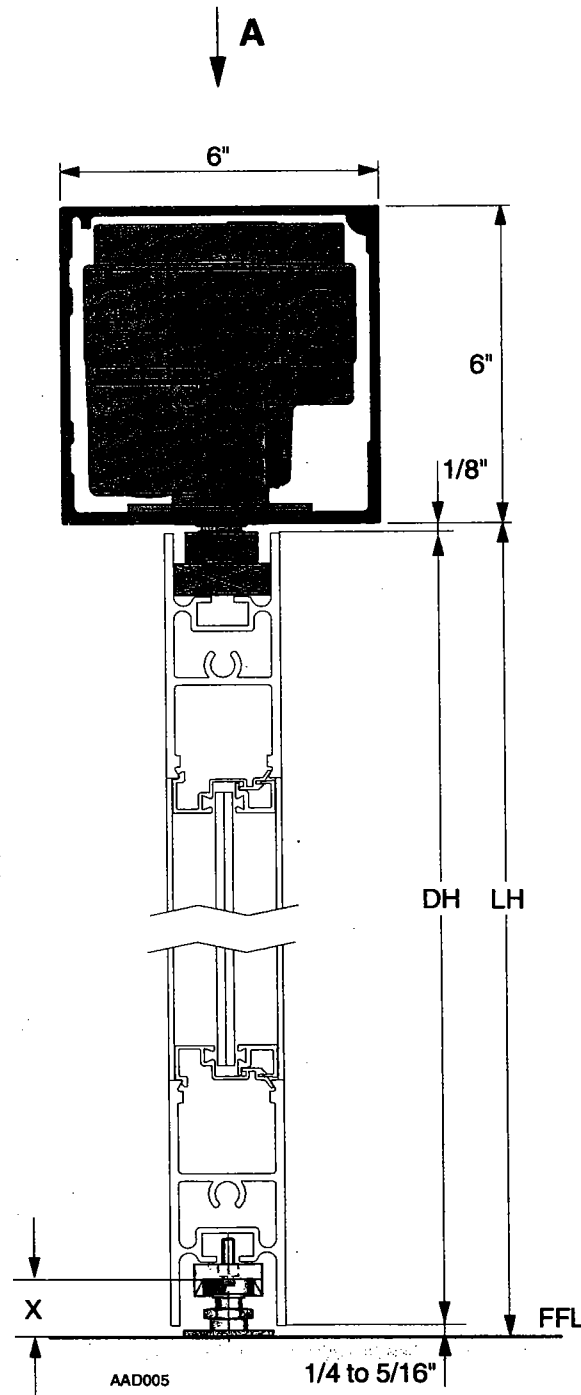
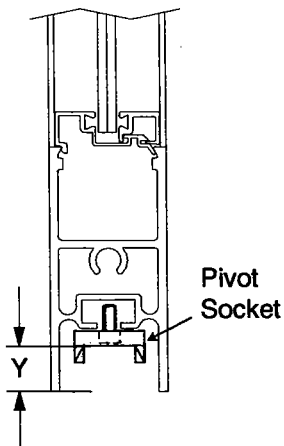

DH = Door leaf height
 LH = Door opening height
 FFL = Finished floor level
 L = Header length

Concealed Installation

Installation for center pivot doors

See page 18 for instructions.

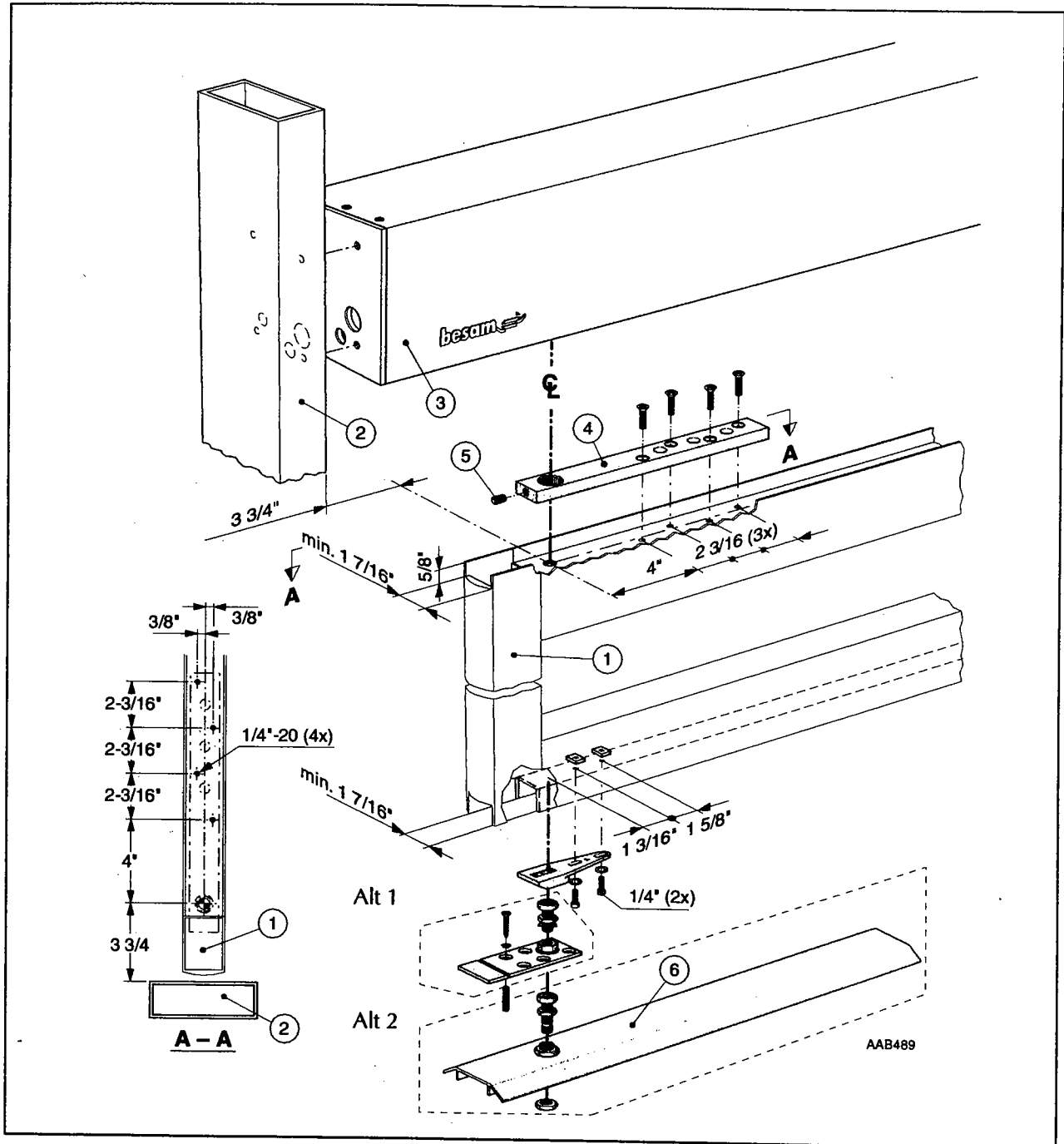

- | | | | |
|---|----------------|---|-------------------------|
| ① | Door leaf | ⑤ | Lock screw |
| ② | Jamb/wall | ⑥ | Threshold (optional) |
| ③ | Header housing | ⊥ | Drive shaft center line |
| ④ | Drive arm | | |

Concealed Installation

Checking routine before installation

1. Check that the wall cutout has the proper reinforcements and that the floor is level and smooth.
2. Make sure that the delivered operator suits the door, based on the pre-installation questions on page 10. The operator will consist of a factory-assembled header, a drive unit, a drive arm, a control unit, and optional accessories.

Door leaf preparation for center pivot doors

There must be cut-outs in the heel of the door, both at the top for the drive arm and at the bottom for the bottom pivot. See page 17.

Mounting the drive arm on top of the door leaf

Check the B-dimension (distance from the vertical jamb/wall to the drive shaft center line, 3-3/4"). Use the drive arm as a template, properly centered. Drill and tap the four fastening holes, or use rivnuts, in the top rail of the door. If the web depth is greater than 5/8", a spacer under the drive arm and longer screws may be required. (A 3/8" spacer is available from Besam - see page 8.) The top of the drive arm should be flush with the top of the door. Fasten the drive arm and check the dimensions. If a mistake is made, the drive arm may be turned over and a new set of holes located to correct the problem. Remove the drive arm.

Installation of side-load header and drive unit in installed frame

1. Establish the door opening height (LH) and the correct length (L) of the operator (see page 16).
2. Dismantle the casing, separating the header, cover, short and long center panels, and end caps.
3. Use provided templates, or use end caps as templates, and drill appropriate header mounting holes and cable inlets.

Note: The cables can enter the operator from the hinge/pivot side or from the strike side. Try to bring all wiring in at the strike side because of the tight conditions between the drive unit and cover.

4. Install the endcaps using appropriate screws, or rivnuts if required.
5. Install the header onto the end caps. Check straightness with carpenter's level.
6. Install the short center panel to the header/end cap with the outer screws, on the right or left side depending on the type of door.
7. Install the drive unit and secure it with the spindle bracket to the short center panel.
8. Install the long center panel to the header and secure it to the drive unit rear mount.
9. Install CUP and make electrical connections (see pages 38-39), then install the cover.

Installation of side-load header and drive unit in uninstalled frame

Attach end caps and header to jambs as described above (steps 1-5). Tilt header/jamb assembly up into rough opening in wall. Level header and plumb jambs, shimming appropriately. Fasten jambs, then proceed with installation as described above.

Details will vary widely according to the nature of the installation site.

Concealed Installation

Mounting the bottom pivot

Prepare and install the bottom pivot (see pages 15-16). The bottom pivot can be installed in two ways:

Alt 1: With the base plate/bearing placed directly on the floor. The distance 3-3/4" to the pivot center line is obtained if the base plate is placed against the vertical jamb/wall.

Alt 2: With the bearing installed directly into the threshold.

Make sure that the center line of the bottom pivot and the center line of the drive shaft are aligned. **Tip: Use plumb bob.**

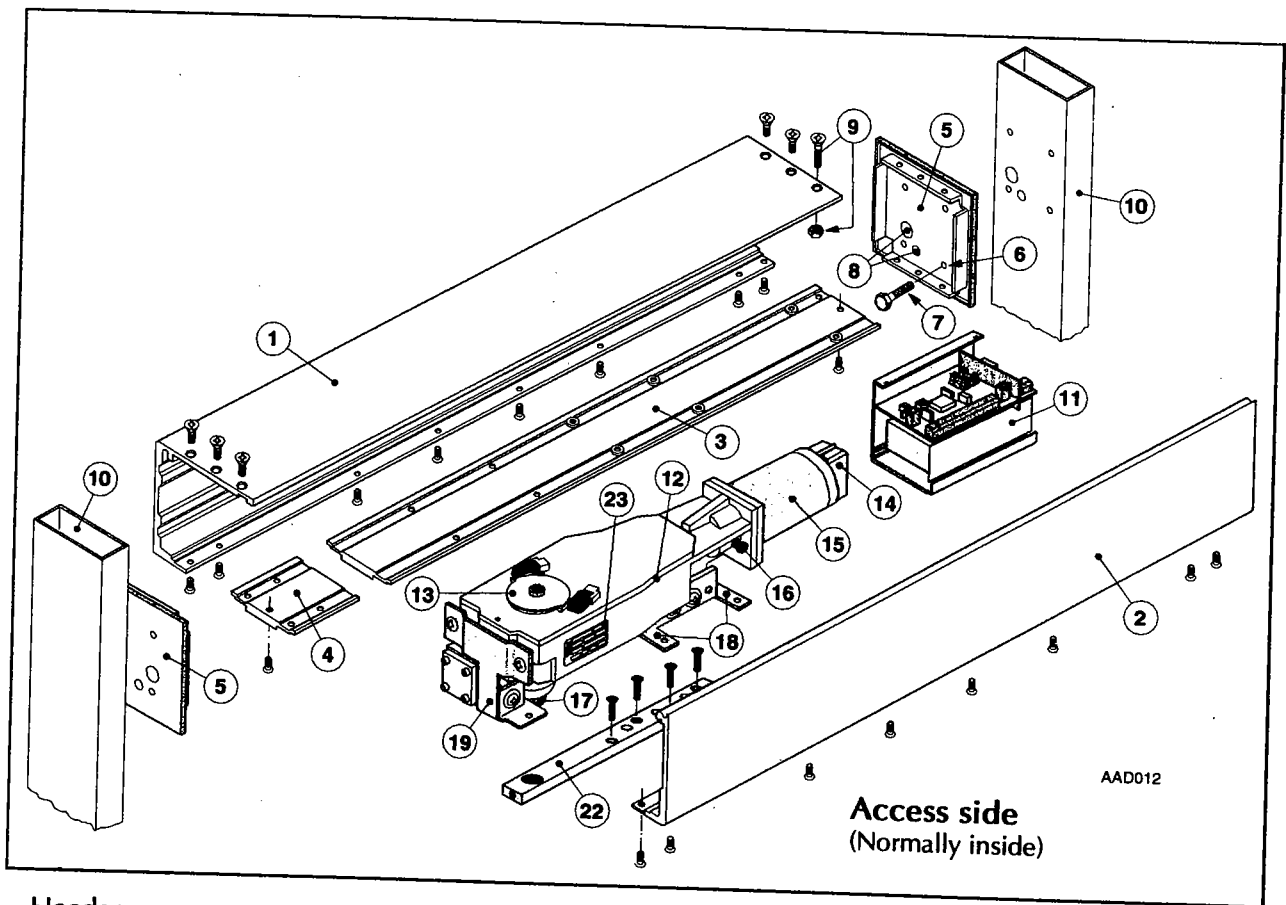

- | | | |
|------------------------|-------------------------|----------------------------|
| (1) Header | (9) Ground Bolt (1) | (17) Spindle |
| (2) Cover | (10) Jamb / Wall | (18) Rear Mount |
| (3) Long Center Panel | (11) CUP Control Unit | (19) Front Mount |
| (4) Short Center Panel | (12) Drive Unit | (22) Drive Arm (Concealed) |
| (5) End Caps (Two) | (13) Cam and Switches | (23) Label |
| (6) Mounting Holes (8) | (14) Revolution Counter | |
| (7) Mounting Bolts (8) | (15) Motor | |
| (8) Cable Holes (2) | (16) Spindle Lock Screw | |

Concealed Installation

Installation of door leaf

The door leaf must be prepared for the drive arm and bottom pivot per instructions on pages 16-19.

Note: Step 5 below is critical. The door must be allowed to self-adjust to the bottom pivot.

1. Adjust the bottom pivot using instructions on page 15.
2. Fit the drive arm to the drive unit drive shaft in line with the desired closed position for the door (0-position), and temporarily fix it with the drive arm set screw. Rotate the drive arm to the fully open door position (90°) and install the locking thumb screw onto the drive unit to hold the drive arm in this position. Note that the drive arm will be very hard to move.
3. With the drive arm still attached to the drive unit shaft and the bottom pivot set in place, slide the door in from the hinge end over the bottom pivot and guide the drive arm into the top web of the door.
4. Move the door in until the screw holes in the door line up with the holes in the drive arm and apply the four screws through the arm to connect it to the top of the door.
5. Loosen the drive arm set screw and allow the arm and door to settle against the bottom pivot.
6. Check that the door has 1/8" maximum clearance at top and does not interfere with the bottom pivot plate. Remove the door and adjust the bottom pivot if necessary.
7. Tighten the four screws in the drive arm/door and then re-tighten the set screw in the drive arm.
8. Release the locking thumb screw and allow the door to close.

Concealed Installation

Adjustment of built-in mechanical opening door stops

The operator assumes rest position (0-position) when the door is closed. If necessary, this 0-position can be adjusted by loosening the lock nut ③ and turning the complete spring tube (see below).

The built-in mechanical opening door stops are factory-set to a maximum 95° opening angle and normally will not need adjustment. If required, the opening door stops can be adjusted as shown below. Mechanical door stops must be adjusted with the operator removed from the header.

Note: The mechanical stops are not intended to control the normal full open position, as the CUP controller handles this electronically. Mechanical stops are intended as abuse stops, and should normally be adjusted to 5° greater than the desired opening.

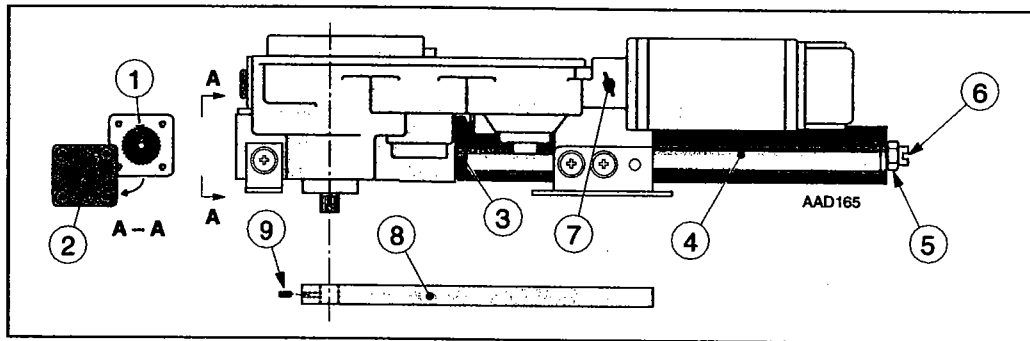

- | | |
|--|---|
| ① Left-handed drive unit: Adjustment bolt for opening angle. Screw out to increase and in to decrease. Must be adjusted with drive unit removed from header! | ⑤ Door stop locking nut (right-handed drive unit) |
| ② Spring tube end plate | ⑥ Right-handed drive unit: Adjustment bolt for opening angle. Screw out to increase and in to decrease. |
| ③ Lock nut for the spring tube | ⑦ Locking thumb screw |
| ④ Spring tube | ⑧ Drive arm |
| | ⑨ Lock screw |

Note: With push arms and concealed arms, it is recommended that an extra mechanical door stop be provided to prevent misuse accidents and high wind problems. Check with local codes to verify that such a door stop is permissible.

Caution! If this is an inswing door used for egress, check local codes before adding any door stops!

Surface Mount Installation

The surface mount operator (IKS-A) is used to control all types of swing doors. The operator is mounted on either side of the door header, and the door is controlled with a push or pull arm system.

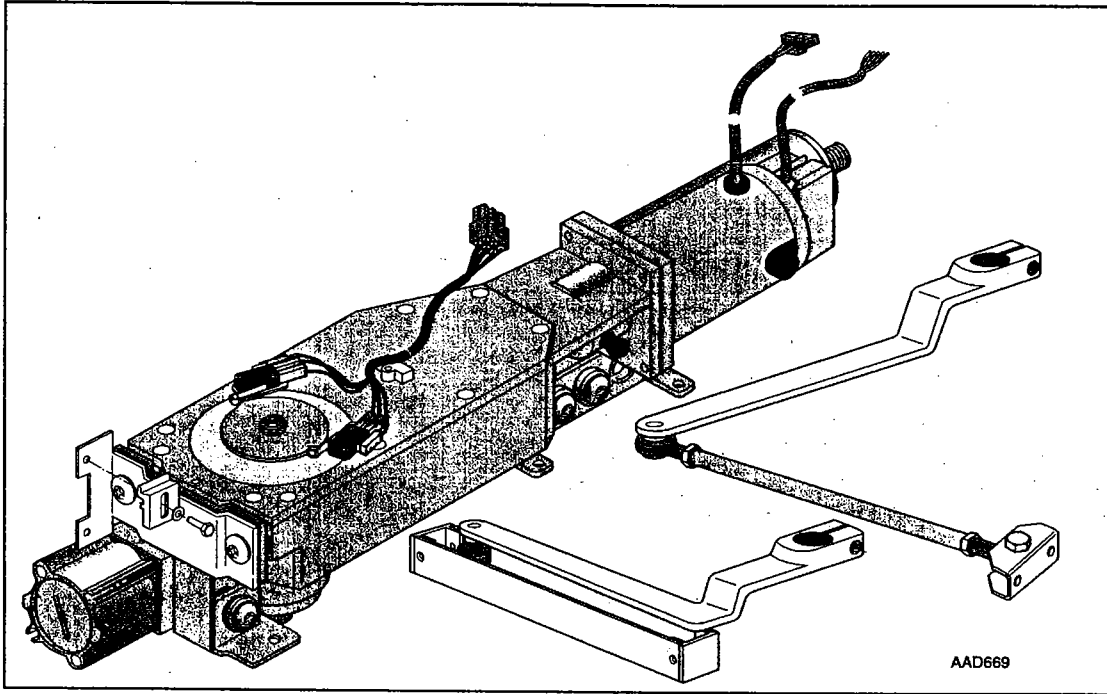

Models

Pushing arm system type NAS on a left-handed door shown (header/case side).

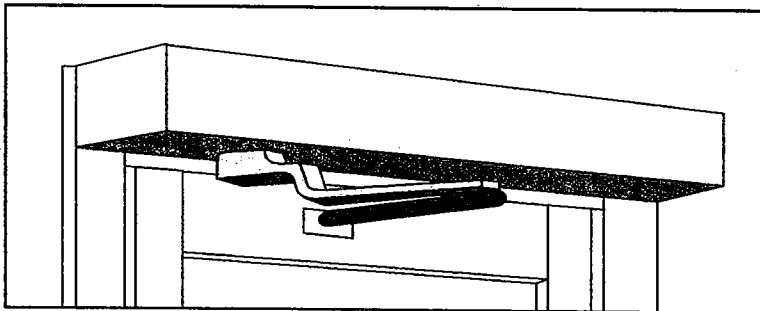

Pushing arm system type NAS on a right-handed door shown (header/case side).

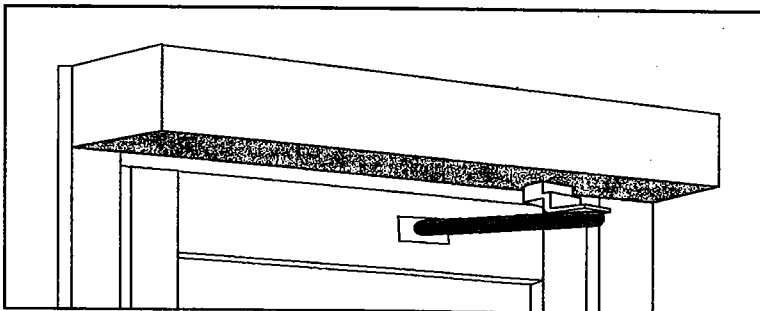

Surface Mount Installation

1. Establish the installation height and the correct width of the header.
2. Dismantle the header from the cover.
3. Mark and drill the fixing holes and the holes for the cable inlet in the header (see drawing for the arm system used, page 24 or 25).
4. Use the header as a template. Mark and drill for cable inlets and mounting holes into the jamb/header (non-pivot side preferable) for the correct operator model and arm system.
5. Install the header using appropriate screws, or if required, rivnuts. Check straightness with carpenter's level.
6. Install the external cables through the cable inlet holes. The cables can enter the casing from the hinge/pivot side or from the strike side, but it is always desirable to bring all wiring in at the strike side because of the tight conditions between the drive unit and the cover.
7. Install the short center panel to the header on the right or left side according to the handing of the door.
8. Install the end caps.
9. Secure the front mount to the short center panel, then attach the support bracket and clamp plate to the header as shown in the illustration on page 23.
10. Install the long center panel to the header and secure it to the rear mount.
11. Mount the shaft adapter on the drive shaft (see page 23).
12. Mount the arm system and the door fitting (see page 26 or 27).
13. Install CUP and make electrical connections (see pages 38-39), then install the cover.

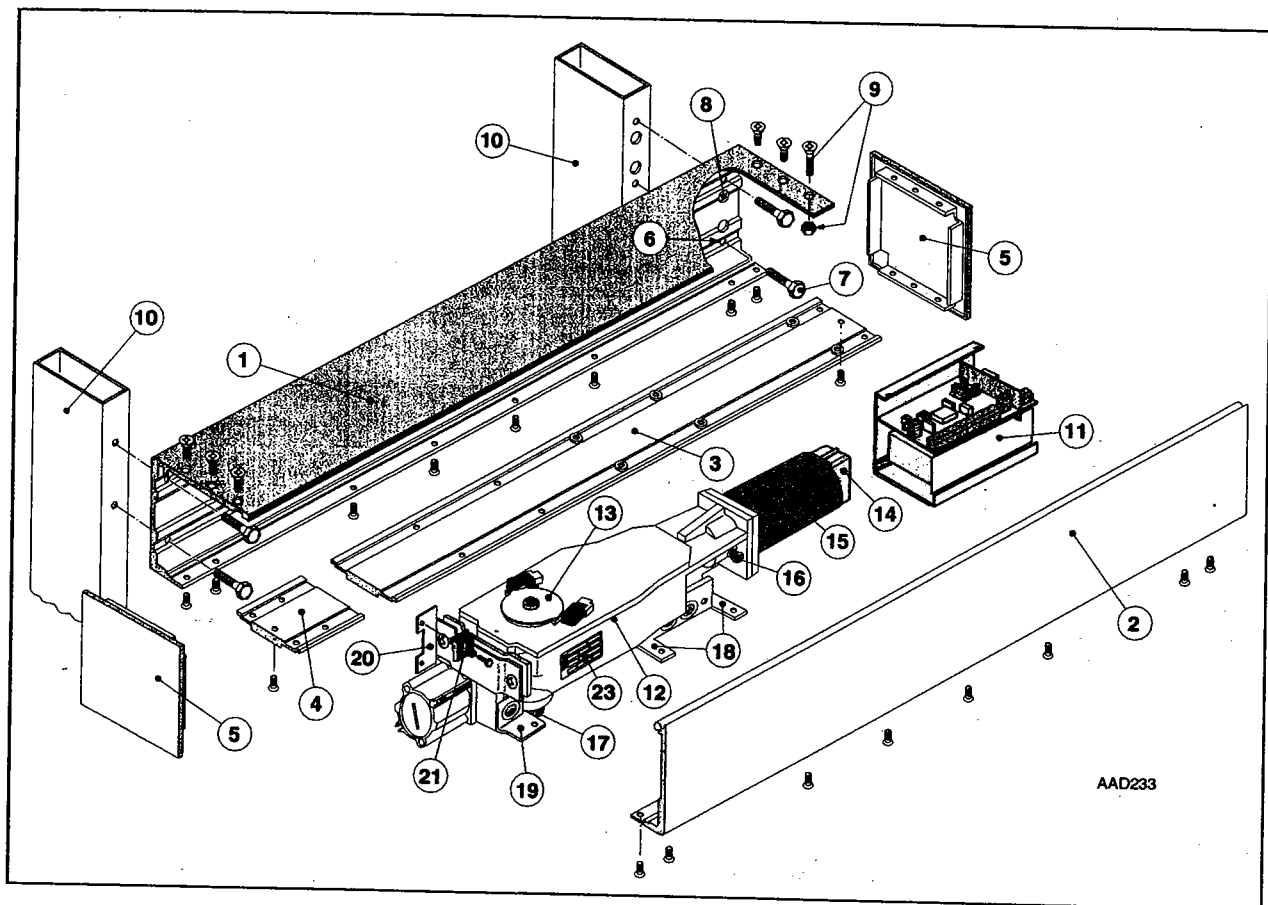

Surface Mount Installation

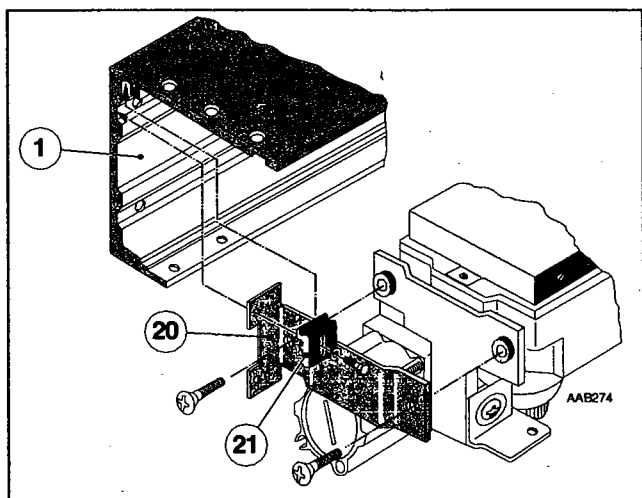

- (1) Header
- (2) Cover
- (3) Long Center Panel
- (4) Short Center Panel
- (5) End Caps (Two)
- (6) Header Mounting Holes (4)
- (7) Mounting Bolts (4)
- (8) Cable Holes (2)
- (9) Ground Bolt (1)
- (10) Jamb / Wall
- (11) CUP Control Unit
- (12) Drive Unit
- (13) Cam and Switches
- (14) Revolution Counter
- (15) Motor
- (16) Spindle Lock Screw
- (17) Drive Spindle
- (18) Rear Mount
- (19) Front Mount
- (20) Support Bracket
- (21) Clamp Plate
- (23) Label

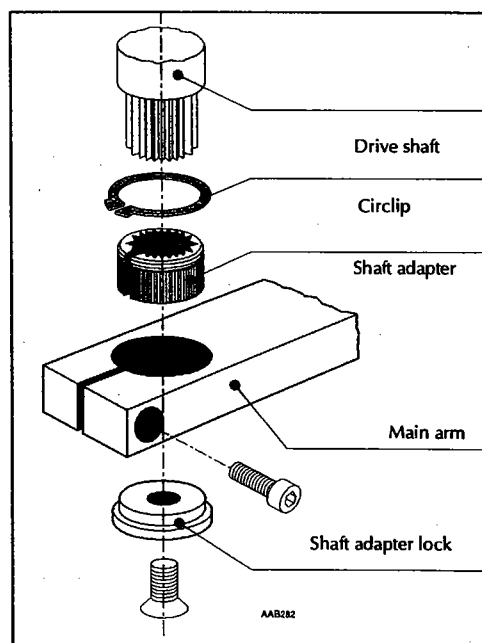

Arm systems (Surface applied)

The arm system incorporates an adapter, which fits the splines of the drive shaft and permits fine adjustment of the arm system angle.

See pages 60-61 for a listing of all parts in each arm assembly.

Surface Mount Installation - Push

Pushing arm system, NAS

The NAS (pushing arm system) consists of a main arm, connecting rod, arm shoe and shaft adapter.

If the reveal "A" (the distance from the wall surface to the door surface) is more than 4 inches, a longer connecting rod is needed for the NAS (see page 8). The maximum standard reveal is 12" (consult factory for larger reveals). All dimensions given here correspond to an opening angle of 90-100°.

Operator with NAS on a left-handed door shown (right-handed door mirror image)

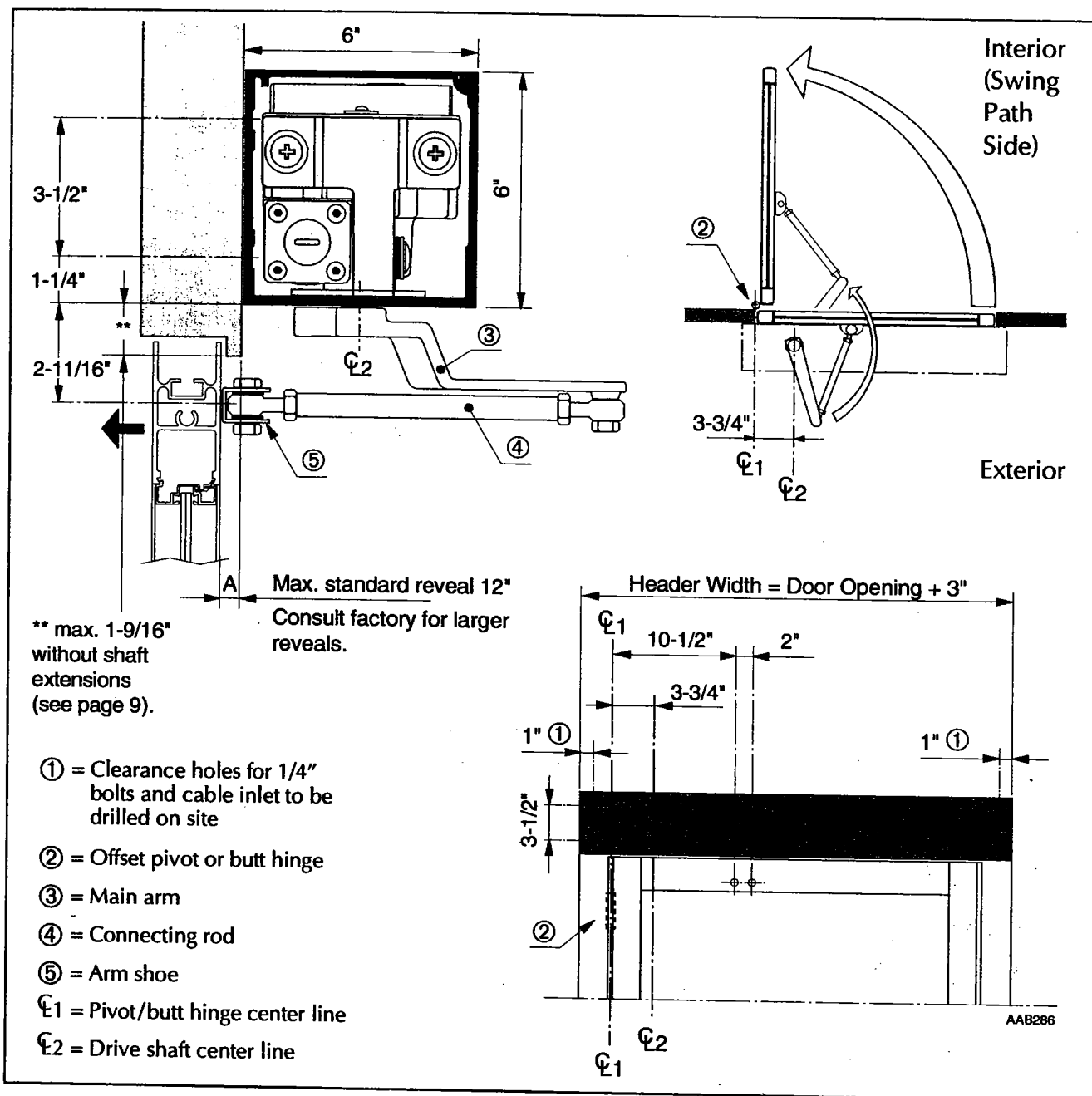

Surface Mount Installation - Pull

Pulling arm system, PAS

The PAS (pulling arm system) consists of a main arm, guide track, roller guide and shaft adapter. The maximum reveal, or distance from the wall line to the door leaf (A), should not exceed 5 inches.

For center pivot doors only: if the reveal is one inch or less, use the standard length (15") guide track; if the distance is between 1" to 5", use a longer (20"+) guide track (see page 8). All dimensions given here correspond to an opening angle of 90-100°.

Operator with PAS on a right-handed door shown (left-handed door mirror image)

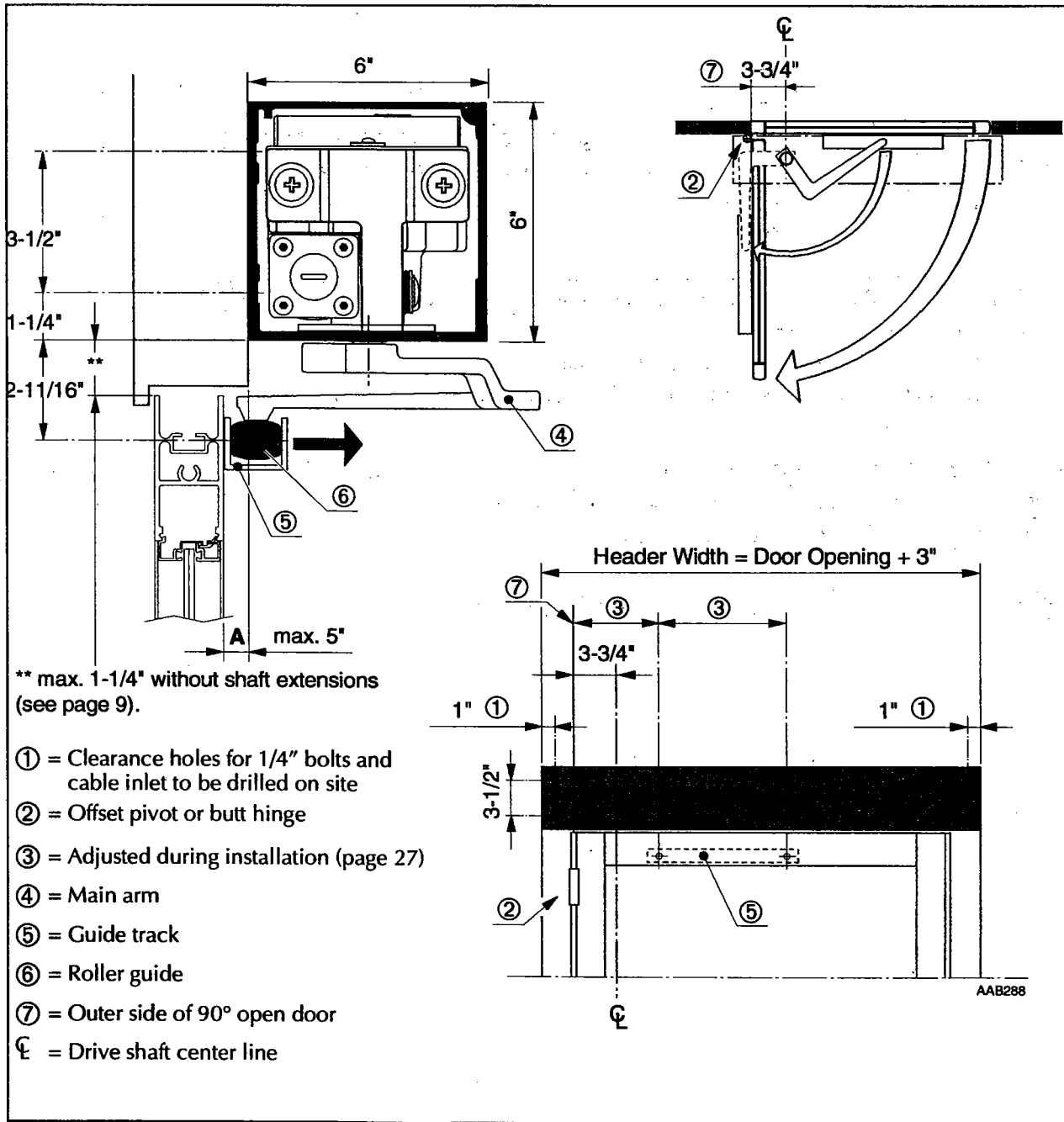

Surface Mount Installation

Adjustment of built-in mechanical opening door stops

The built-in mechanical opening door stops are factory-set to a maximum 95° opening angle and **normally will not need adjustment**. If required, the opening door stops can be adjusted as shown below. Mechanical door stops must be adjusted with the operator removed from the header.

Note: The mechanical stops are not intended to control the normal full open position, as the CUP controller handles this electronically. Mechanical stops are intended as abuse stops, and should normally be adjusted to 5° greater than the desired opening.

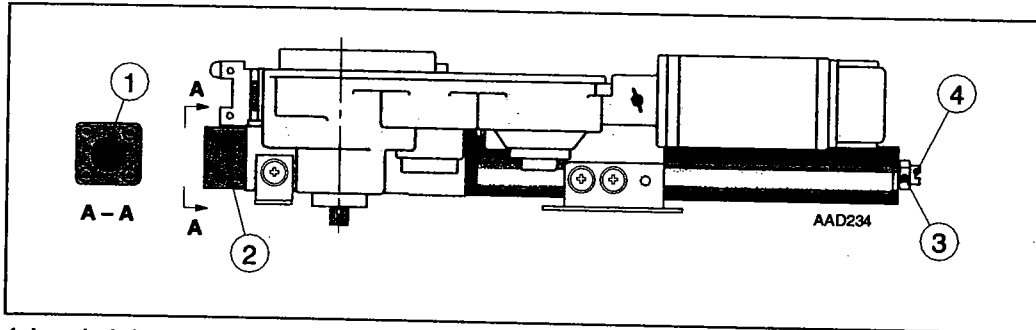

- ① Left-handed drive unit: Adjustment bolt for opening angle. Screw out to increase and in to decrease.
- ② Rack extension housing
- ③ Door stop locking nut (right-handed drive unit)
- ④ Right-handed drive unit: Adjustment bolt for opening angle. Screw out to increase and in to decrease.

Note: With push arms and concealed arms, it is recommended that an extra mechanical door stop be provided to prevent misuse accidents and high wind problems. Check with local codes to verify that such a door stop is permissible.

Caution! If this is an inswing door used for egress, check local codes before adding any door stops!

Surface Mount Installation

Mounting the arm system

Pushing arm system, NAS

1. Locate the door in closed position.
2. Mark the door for the arm shoe fixing holes (see page 24 for correct dimensions).
3. Drill and thread or use rivnuts.
4. Apply the shaft adapter to the drive shaft. Slip the main arm with connecting rod and arm shoe onto the shaft adapter so that the arm shoe meets the door in the proper place.
5. Tighten the main arm to the drive shaft.
6. Attach the arm shoe with screws as required.

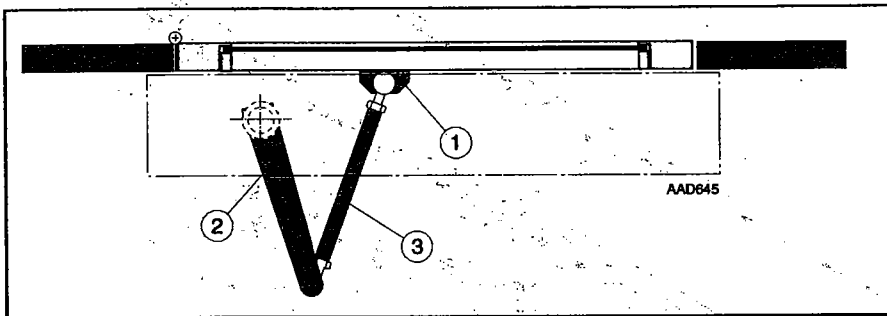

- ① Arm shoe
- ② Main arm
- ③ Connecting rod

Pulling arm system, PAS

1. Locate the door in closed position.
2. Slip the main arm with roller guide onto the shaft adapter –which has been applied to the drive shaft earlier–so that the roller is just in contact with the door.
3. Tighten the main arm to the drive shaft.
4. During the opening and closing movement of the door, the roller guide will move a certain distance on the door. Mark the end positions for this distance.
Note! The end positions do not always occur when the door is fully closed and fully open.)
5. To make the installation of the guide track easier, open the door to approx. 90°, lock the arm with the thumb screw and close the door.
6. Position the guide track symmetrically over the marks on the door, with the center of the fixing holes 2-3/4 from the lower edge of the operator. Mark on the door for the fixing holes. Drill and thread or use rivnuts.
7. Release the locking thumb screw. The main arm moves back and stops when the roller hits the door.
8. Attach the guide track to the door with the roller guide fitted into the track. Use appropriate screws.

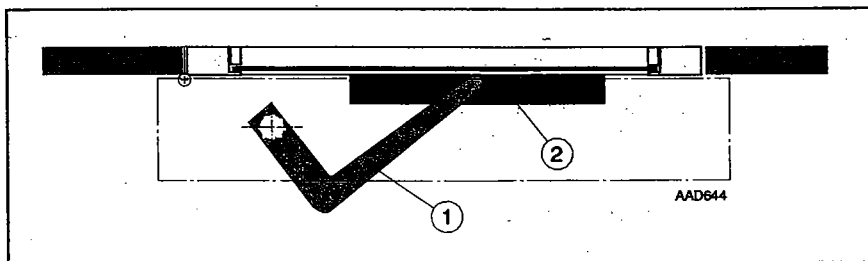

- ① Main arm
- ② Guide Track

Bottom Load Installation

Parts and installation

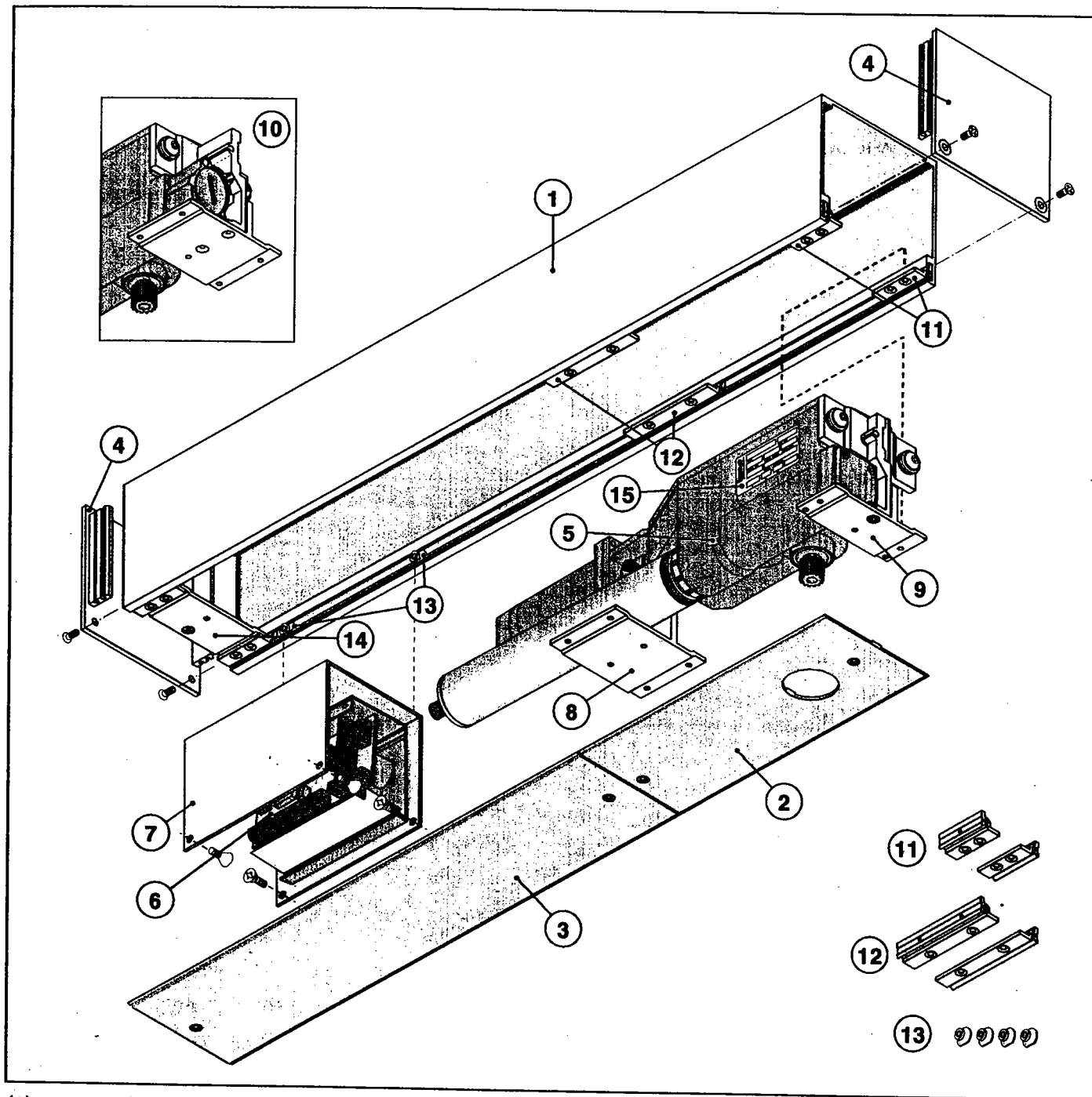

- | | | |
|----------------------|---|--------------------------------|
| (1) Header | (7) Control Unit Bracket | (11) Short Brackets |
| (2) Short Cover | (8) Rear Drive Unit Mount | (12) Long Brackets |
| (3) Long Cover | (9) Front Drive Unit Mount (OHC) | (13) Control Unit Bracket Nuts |
| (4) End Caps (Two) | (10) Front Drive Unit Mount (Surface Applied) | (14) Cover Mount |
| (5) Drive Unit | | (15) Label |
| (6) CUP Control Unit | | |

Bottom Load Installation

Installation

1. Establish the clear opening height (LH) and the correct length (L) of the operator (see page 15).
2. Mark and drill mounting holes, according to your type of installation (concealed or surface mount). Use the drilled holes as templates, and drill, tap or use rivnuts in the vertical jambs/walls.
3. Make sure that the short and long mounting brackets and the control unit bracket nuts have been inserted into the appropriate grooves in the header, as shown in the illustration.

Concealed: Tighten both pairs of short brackets at the ends of the header. Attach the end caps to these brackets.

Surface Mount: Tighten one pair of short and one pair of long brackets at the ends of the header, with the short pair at the strike side of the installation. You can leave the end caps off at this point to ease installation of the drive unit.

4. Install the header onto the jambs/wall. Check straightness with carpenter's level.
5. Drill the holes for cable inlets. The cables can enter the operator from the strike side or from the hinge/pivot side. Try to bring all wiring in at the strike side because of the tight conditions between the drive unit and cover. Install the external cables through the cable inlet holes.
6. Measure the desired position of the drive unit. Position the central long brackets to meet the rear mount of the drive unit, and tighten. Lift the drive unit into place and secure it to the central and hinge-side brackets with eight screws.
7. Install the CUP control unit into its support bracket. Screw the control unit bracket loosely to the control unit bracket nuts. Make wiring connections, then tighten the bracket. (See page 38-39 for wiring instructions.)
8. Snap in the long and short cover plates. (Surface mount: slide in cover plates and attach end caps.) Apply screws and tighten the covers.

Fire Door Installation

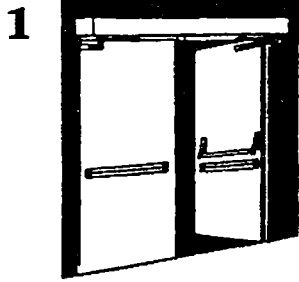

1) Normal Operation: Doors provide separation of spaces but function as a fully automatic door system.

2) When people approach the doors, they will open automatically, and close once someone has passed through the doorway.

3) In the event of smoke, fire or a power failure, a UL listed sensing device (smoke, heat or central alarm detector) sends an impulse to deactivate the operator and the F-50 latch mechanism.

4) Automation to the doors is removed. The fire door latches positively secure after each manual operation. The doors now function as manual fire doors.

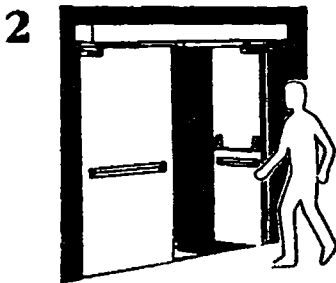

5) When power is restored or alarm condition is removed, push the reset button of the F-50 series latch and depress the crossbar of the panic device to unlatch the door and restore automatic operation.

What is provided by Besam?

The fire door accessory package is a complete Underwriter's Laboratories (UL and CUL) listed package:

Swingmaster MP surface-applied automatic swing door operator (for exterior and heavy-duty use).

F-50 series electro-magnetic latch mechanism to keep upper and lower panic device vertical rods in retracted position.

Standard activating and safety devices: Visionpulse presence sensors, push plate switches or contact mats.

Caution labels.

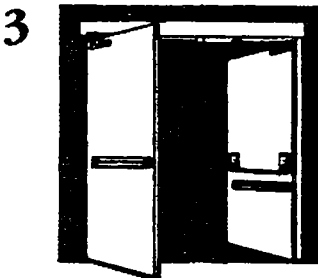

What is provided by you?

UL listed fire doors and frames.

For pairs of doors - UL listed fire exit hardware (concealed or surface applied).

UL listed sensing device for smoke or heat (accessory package may be wired directly into the central alarm system if available).

For single doors - UL listed electric strike compatible with UL listed rim panic device (concealed or surface rod devices are not approved for single doors).

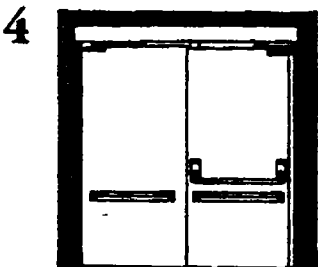

Besam's automatic fire door accessory package, Swingmaster MP, is designed to be used with "A" or "B" labeled fire doors.

SINGLE DOOR

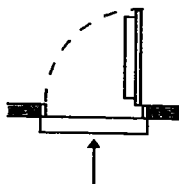

PAIR OF DOORS

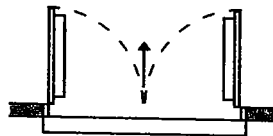

DOUBLE EGRESS

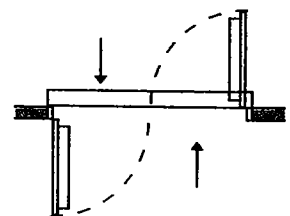

Fire Door Installation

Besam F-50 series latch.

Operator is surface applied, mounted with push arm. (Latch, panic & wiring details.)

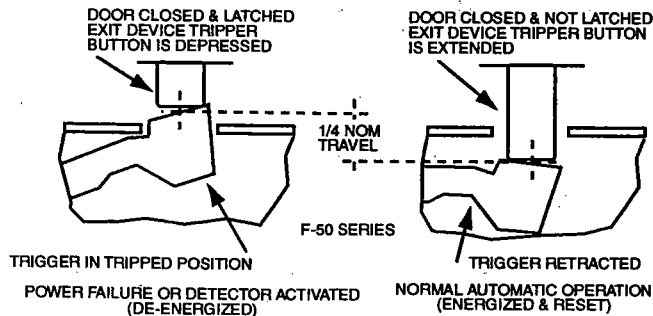
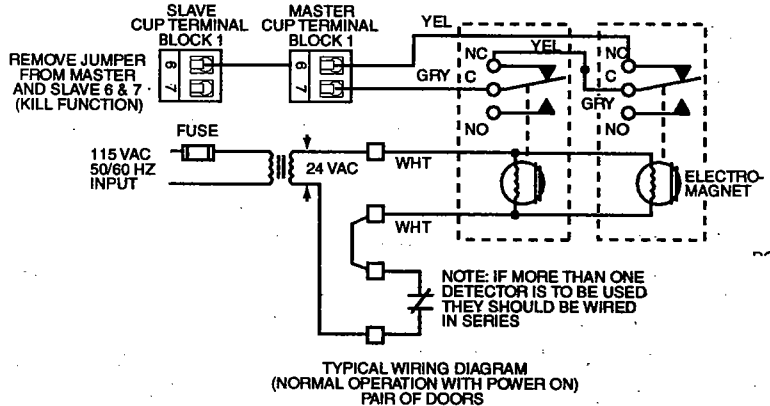
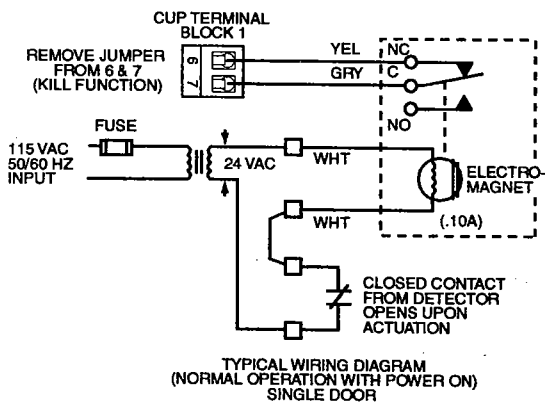
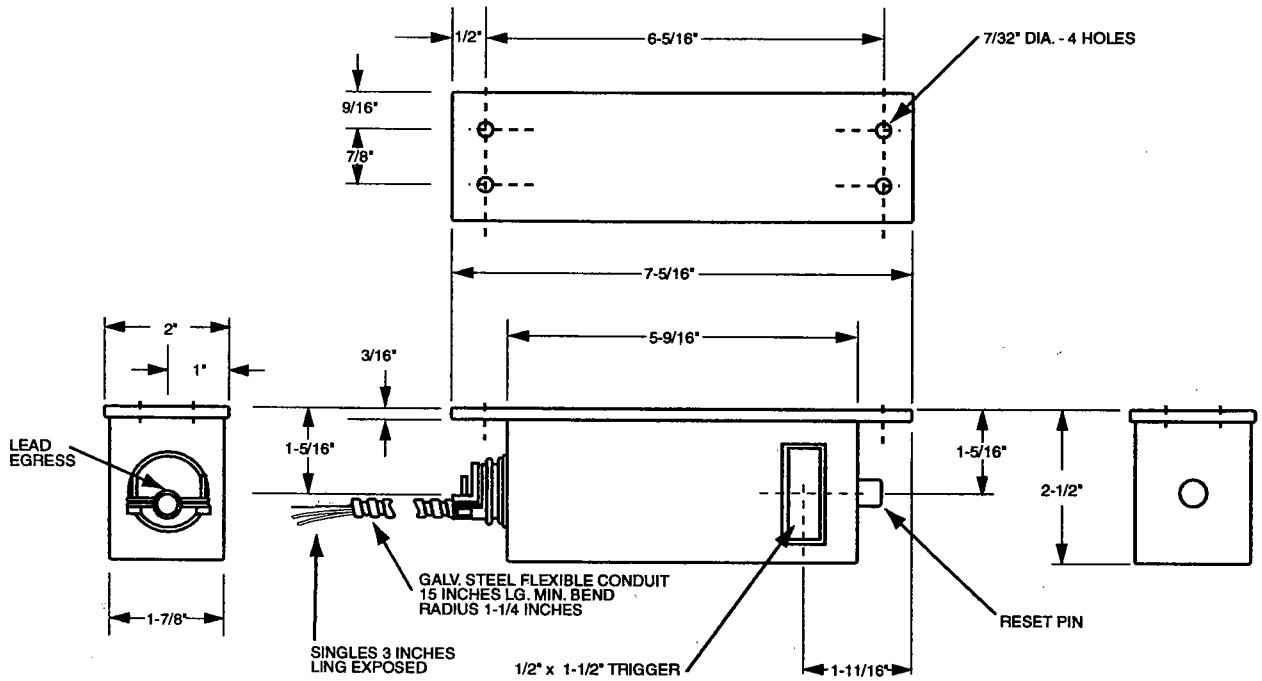

Fire Door Installation

Besam F-50 series latch.

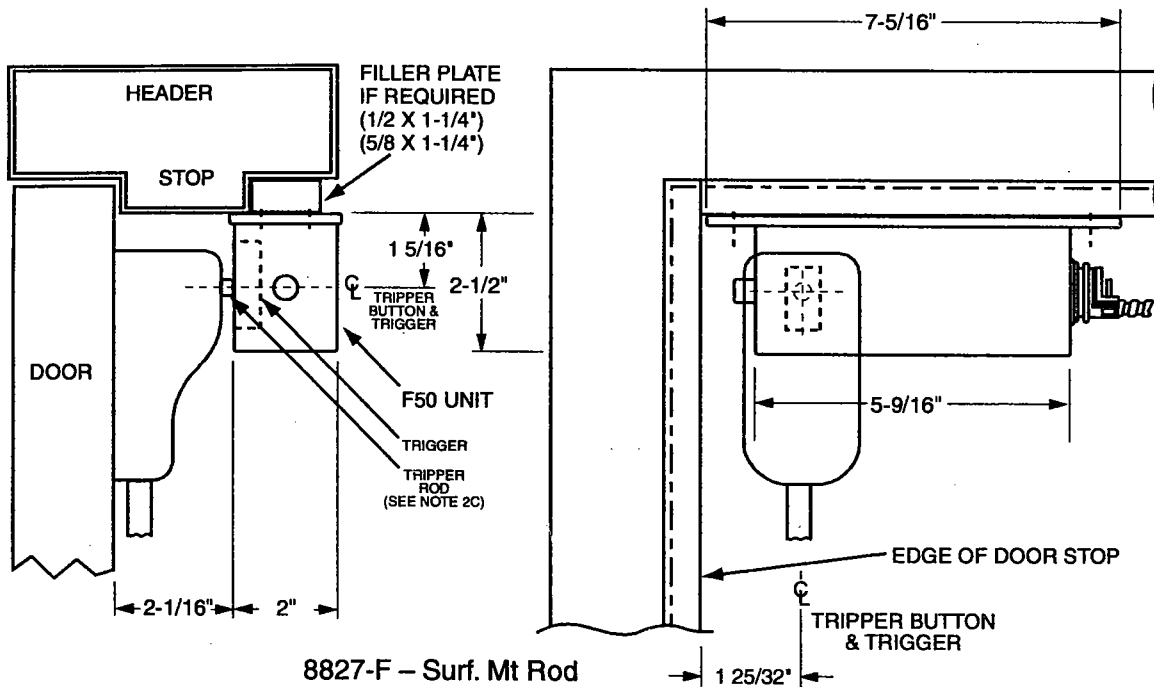

Notes:

1. The electro-magnetic latch release is located in line with the tripper button of the Von Duprin vertical rod exit device.
2. Mounting of the latch release:
 - A. If filler plate is required, mount to top surface of frame as shown, using mounting hardware provided.
 - B. Close and latch the door. Depress the exit device tripper button, and hold with tape if needed.
 - C. Hold latch release against top mounting surface of frame and center latch release trigger in line with the rod, with the tripper button just touching the trigger.
 - D. Spot centers for four mounting holes, using the 490 mounting plate as a template.
 - E. Remove latch release and tap or drill four holes for #10-24 machine screws or #10 sheet metal screws.
 - F. Mount latch release with hardware provided.
 - G. Recheck unit trigger location per step C.

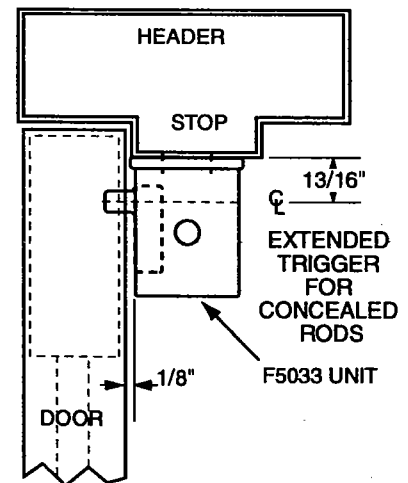

Handing of latch release may be changed by removing the 'L' shaped cover and mounting plate and reassembling in opposite positions.

The cable egress is a flexible metal conduit with a 1-1/4 inch minimum bend radius.

Double Door Installation



Dual with Astragal



Dual



Dual Egress

Double Door Installation

Surface applied dual push (similar for Side Load Concealed & Bottom Load Concealed)

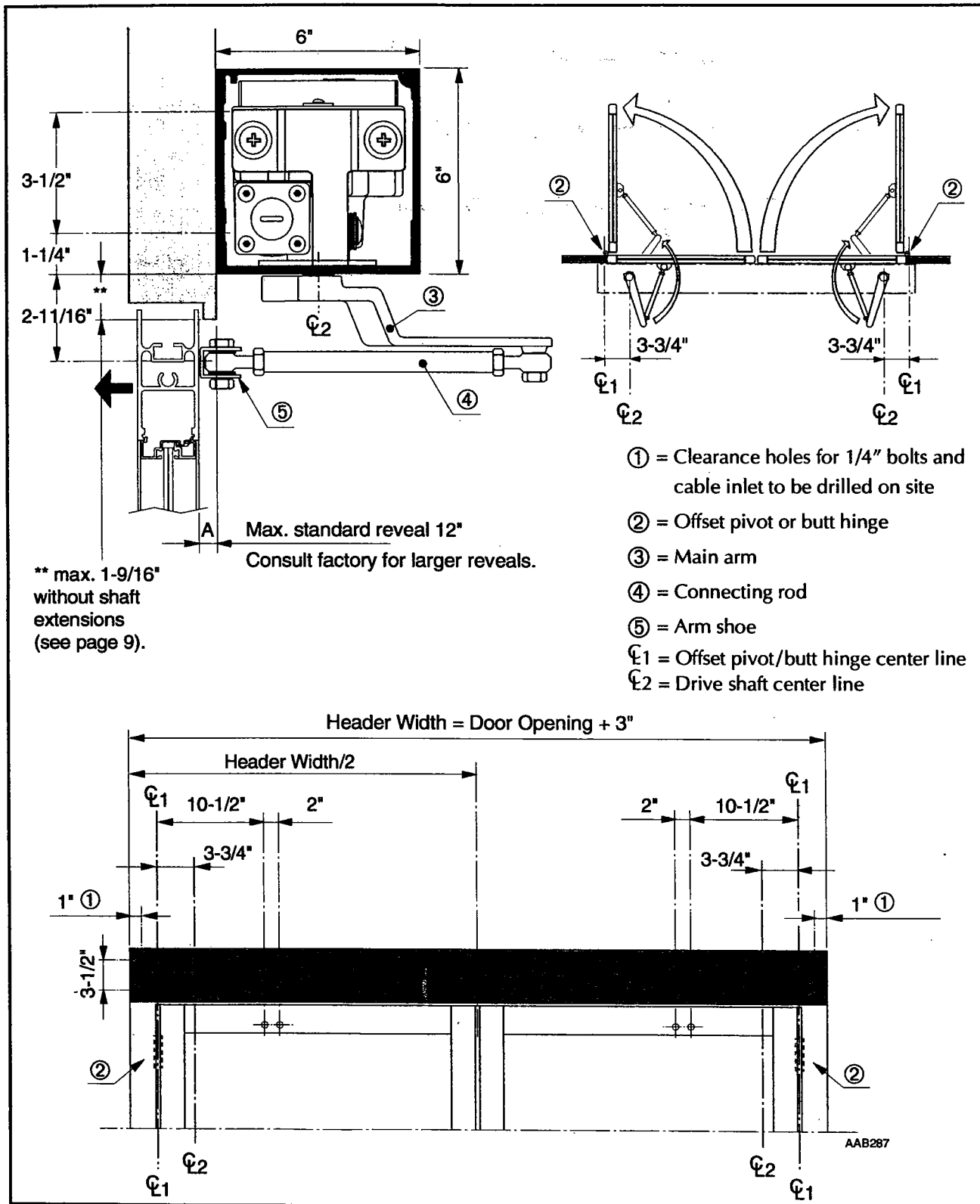

Double Door Installation

Surface applied dual pull (similar for Side Load Concealed & Bottom Load Concealed)

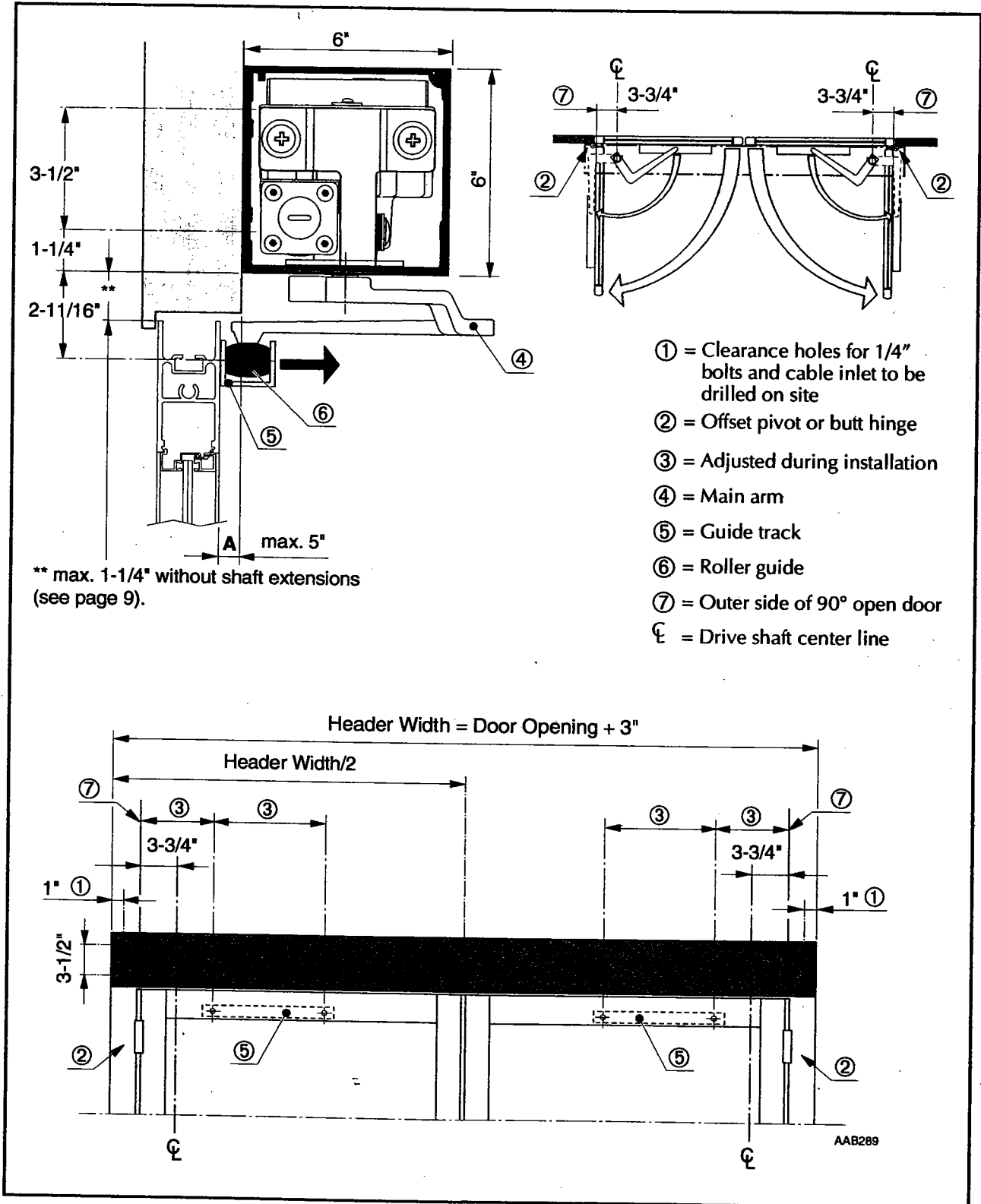

- ① = Clearance holes for 1/4" bolts and cable inlet to be drilled on site
- ② = Offset pivot or butt hinge
- ③ = Adjusted during installation
- ④ = Main arm
- ⑤ = Guide track
- ⑥ = Roller guide
- ⑦ = Outer side of 90° open door
- ℄ = Drive shaft center line

** max. 1-1/4" without shaft extensions (see page 9).

AAB289

Double Door Installation

Surface applied dual egress (similar for Side Load Concealed & Bottom Load Concealed)

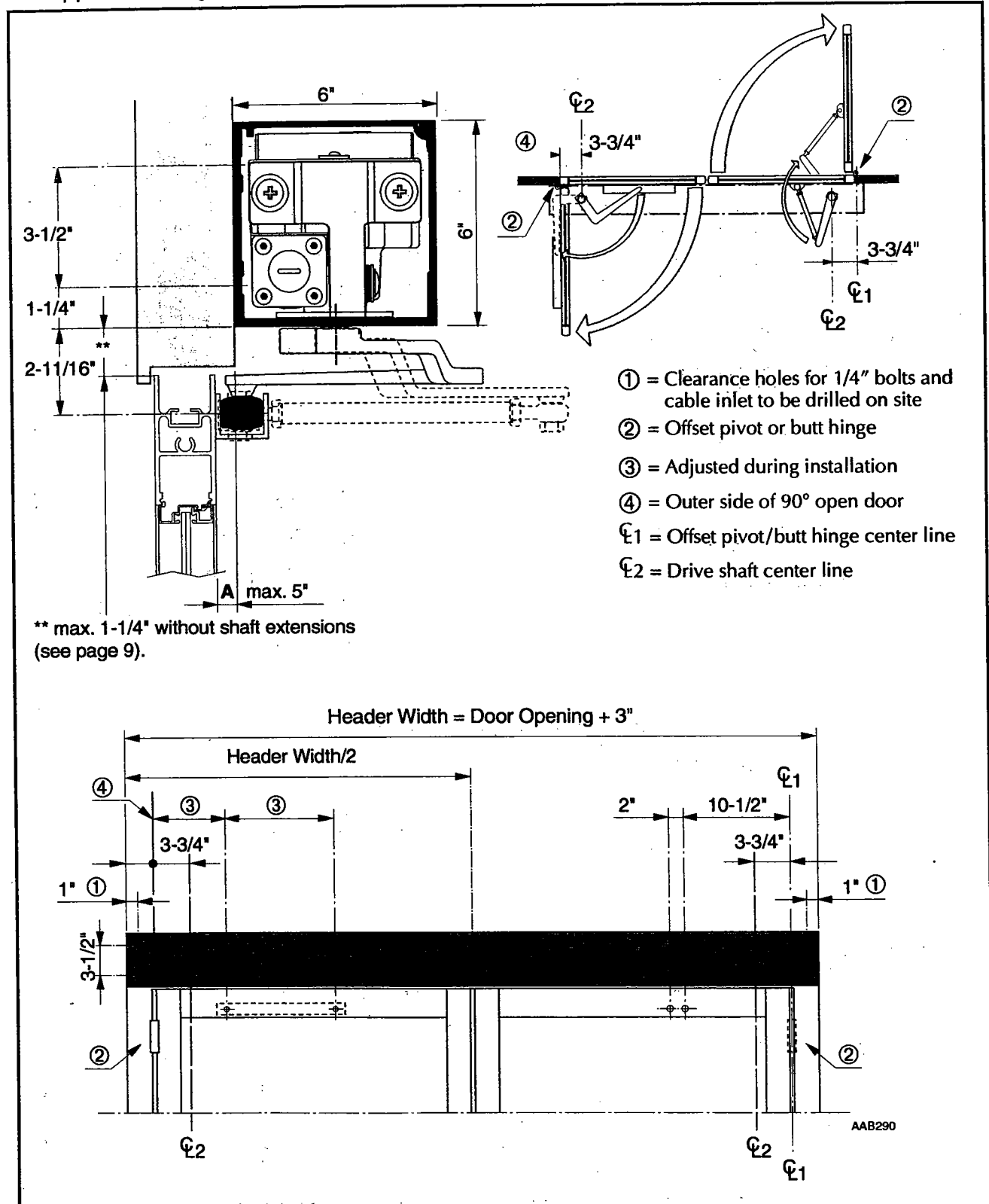

Synchronizing Double Doors With Astragal

In this type of installation, both doors swing in the same direction and one door has an overlapping astragal, requiring one door to close before the other if both doors are to close properly.

Synchronizing

The control units must be wired to each other between the terminals 8, 10, 11, and 12: The control unit/operator for the "active" door leaf is called "master" and for the "passive" door leaf "slave". The opening of the "passive" door leaf is delayed 0.2 seconds to guarantee for a correct opening order without jamming.

Program selector, opening impulses and presence impulses, electro-mechanical locking devices.

These devices are to be connected to the "master" only. (Exception: See 'Manual operation of the master door' below.)

"Push Reactivation" with synchronized wiring

"Push Reactivation" guarantees for a correct closing order. If one of the door leaves is stopped during the closing movement, both door leaves will revert to the open position and close after the hold open time set.

Hold open time

The hold open time and the key hold open time are controlled by the "master" and must be set to "00" on the "slave".

Opening speeds, closing speeds and balance force

These functions are to be adjusted separately for both control units. To make sure that the "passive" door leaf will close first, the closing speed for this leaf must be set faster than for the "active" door leaf.

Power supply

The power supply for activation units, 18 V DC on terminals 19/20, can be used from both control units.

Kill signals

The kill signals are to be connected to both control units.

Manual operation of the "master door"

Set the "Push Reactivation" to "OFF" for the "master" and to "ON" for the "slave". This makes the doors close in the right order. If an electro-mechanical locking device is used on the passive door leaf ("slave") it should be connected to the "slave".

Electrical connections

Note!

During any work with the electrical connections the

- mains power and the
- backup battery must be disconnected.

1. Install the extension unit EXS (if ordered) onto the control unit CUP (see below and page 48).
2. Apply rubber bumpers to the bottom of the CUP control unit. Place the CUP into the header at a convenient location; and connect the CUP ground screw via a ground cable to the ground screw on the header. Be sure that the terminal block is facing the cover (see below, pages 6-7).
3. Connect the cam switch plug, motor plug, revolution counter plug and the protective ground (see page 39).
4. Connect the mains cables (see page 39).
5. Install the backup battery EUS, if ordered (see below and page 47), as space provides.

Note! The activation units and the backup battery EUS are not to be connected until the adjustment of speeds etc. has been carried out.

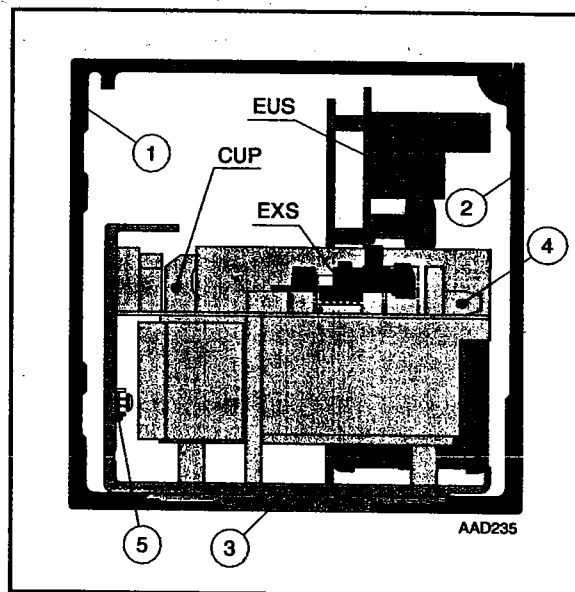

- ① Header
 - ② Cover
 - ③ Long Center Panel
 - ④ Terminal Block
 - ⑤ CUP Ground Screw
- CUP = Control unit
EXS = Extension unit
EUS = Backup battery

Wiring The CUP Control Unit

- ① Cam/Switch cable connector
- ② Connector for motor cable
- ③ Connectors for EXS extension unit
- ④ Connector for revolution counter cable
- ⑤ TB1 – Terminal block for external wiring
- ⑥ TB2 – Terminal block for backup battery, EUS

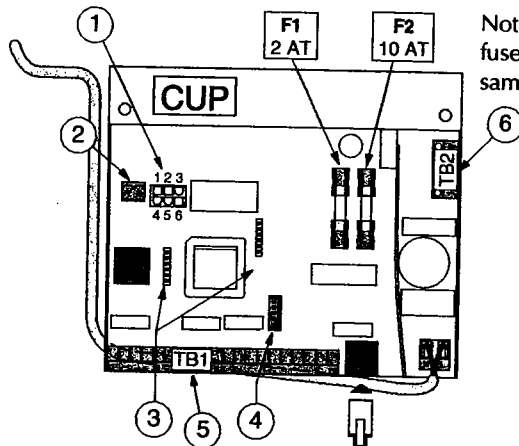

Note! Only replace fuses with those of same rating.

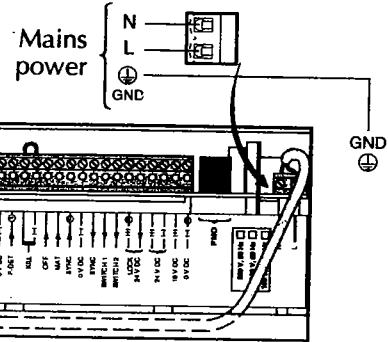

PMD Note! Always enter PIN code first after connecting PMD.

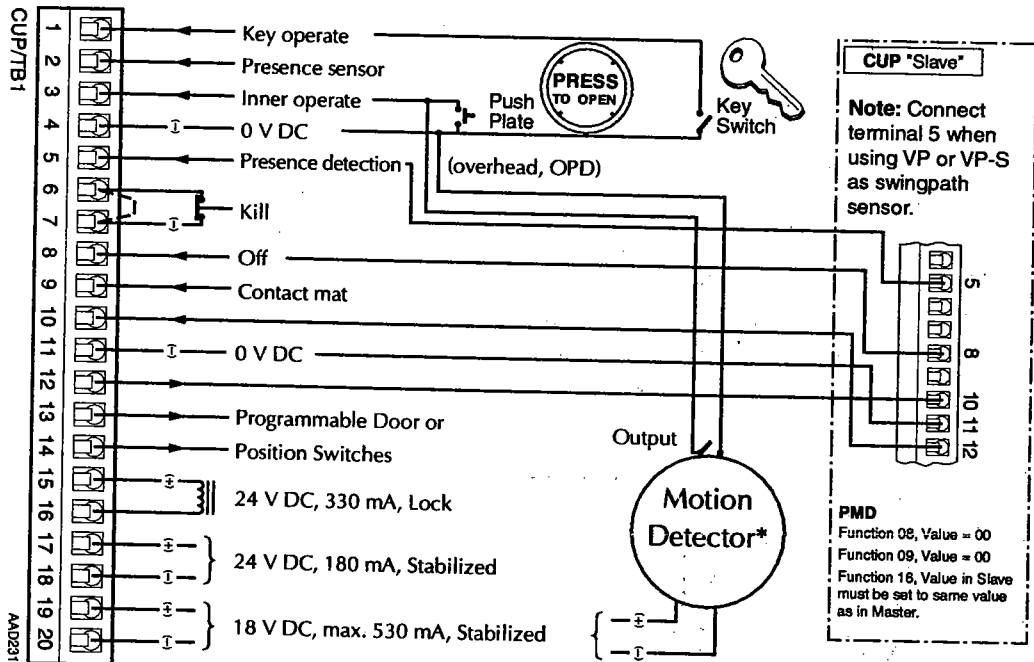

3 Position Switch

1) Legend plate instructions to be placed where they may be easily read.

2) Switch should be mounted within view of the door it is controlling.

3) Switch should be mounted where door opening/closing will not contact the person activating it.

Short 3 & 4 to hold open
Short 4 & 8 to hold closed

Caution!
If switched to off position and Push Reactivation has been chosen, the door will still operate when pushed.

See also page 46.

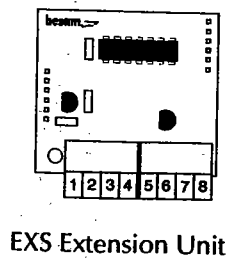
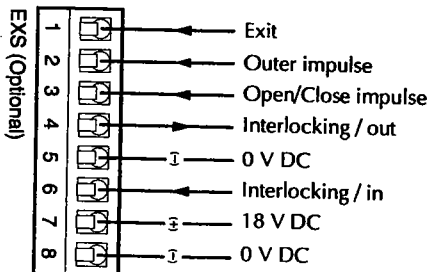

EXS Extension Unit

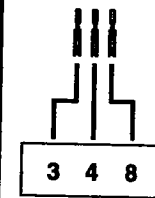
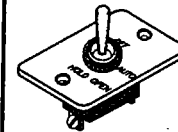

CUP /TB1

* For Visionpulse and Visionpulse S, see respective manuals.

Adjusting The CUP Control Unit

Important Notice!

The Swingmaster, when installed and set up correctly, is a safe automatic power door operator, but incorrect settings can defeat its purpose and create a safety hazard. For safety reasons, never set the opening or closing speed faster than necessary to handle the traffic situation through your door. Please refer to the ANSI/BHMA A156.10 - 1999 excerpt in this manual (page 53). A correctly adjusted door is a safe door!

The start-up and adjustment must be carried out in the following order:

1. Connect the mains power.
2. Plug the PMD contact into the CUP control unit and enter your PIN code (see page 41).
Note! The PMD is not ready for use until a status or error code is displayed.
3. Select function 15 and set correct operator (see page 45).
4. Select function 27 and correct door opening direction.
5. Press button No. 4 (Auto).
6. Press the impulse button I. The operator carries out an open/ close cycle with the factory preset values.
7. If necessary, adjust the door functions to a satisfactory performance.
Note! The door must stand still at closed position when adjustments are carried out. The "balance force" should always be adjusted to the lowest possible value that will still hold the door open against the power of the spring.
8. Install activation units, accessories and EUS battery pack if present.
9. Check that the installation complies with valid regulations and requirements of ANSI/BHMA A156.10-1999 (reference given on pages 53-54 of this manual.)
10. Unplug the PMD, or continue with Visionpulse tuning if installed - see VP-S manual.
11. Fit the cover to the header and screw it tight to the bottom plates.

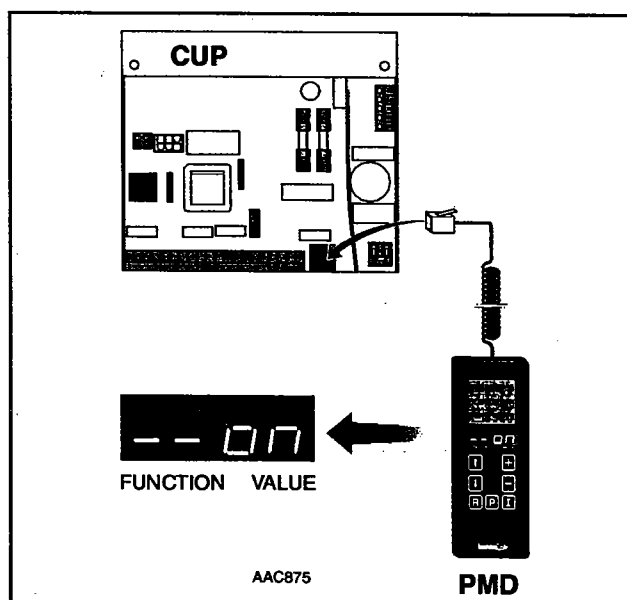

Introduction To PMD

The programming module PMD is used to program the operating values into the control units.

The PMD has a limited service life. A countdown is made at every connection and the remaining "value" is shown on the display. When the figures "-- 71" are shown, the PMD is unusable and must be updated.

PMD models:

- PMD-B Service life: 2000 connections.
- PMD-C Service life: 400 connections.
- PMD-E Customer version with restricted use. Service life: 400 connections.

PIN-code

All new or updated PMDs are factory pre-programmed with the PIN-code "1234".

1. Connect the PMD to the control unit.
2. "Pin_" with a flashing dash will be shown on the display.
3. Enter the code "1234". Every entered digit will be indicated with a dash "_" on the display.

Note! After five unsuccessful attempts to enter the correct PIN-code the error code "71" will be displayed. This means that the PMD is unusable and must be returned to the factory to be updated.

4. Push the button "P".
5. The display will consecutively show:
 - a) Type of control unit e.g. CUD or CUP.
 - b) Remaining "value" of the service life.
 - c) "00".
 - d) Actual status or error code e.g. "on".

Note: If status code 10 is displayed for swing doors, check that the correct operator type has been selected under function 15.

Change of PIN-code

The factory pre-programmed PIN-code can be changed to a personal code as follows:

1. Carry out the instructions 1-5 under "PIN-code" above.
2. Select function "30", value "b".
3. Push the button "P".
4. The display will show four flashing dashes " _ _ _ _".
5. Enter your personal code (four digits). Every entered digit will be shown on the display.

Note! If a wrong digit is entered, disconnect and reconnect the PMD contact and start from the beginning with the factory pre-programmed PIN-code.

6. Push the button "P".
7. "Pin_" with a flashing dash will be shown on the display.
8. Enter your "personal code" and push "P" once more to confirm that the correct code was entered.

Note! It is not possible to revert to old codes if you have forgotten the new one. If a mistake was made during the programming the PMD will revert to step 4 (" _ _ _ _").

PMD – Push Button Set

Function buttons

These buttons are used to set or check* the functions (01-99) for speed, hold open time, monitoring, and so on. The up and down arrow buttons increase and decrease the number by one digit. If the button is held down for more than 1 second, the function number will be increased/decreased every 0.1 second. When the final function (99) has been reached, the digits will roll over to function 01 and start again.

* **Note!** When selecting any of these functions, the last value programmed into the Swingmaster control unit will be displayed, except for function 99, where value 01 will always be displayed.

Value buttons

These buttons are used to set the value for the selected function. The plus and minus buttons increase and decrease the value by one digit. If the button is held down for more than 1 second, the value will be increased/decreased every 0.1 second. When the end value has been reached the digits will roll over and start again.

Program button

This button is used to program the control unit with the function and value selected on the PMD. To indicate that data have been transferred into the control unit, the display will be blank (fractions of a second) and then show the selected digits.

Impulse button

This button is used to give an opening impulse to the operator. If the button is held down, an impulse is given every 0.2 seconds.

Reset button

This button is used to reset the control unit. Hold the button down for about 2 seconds to reset.

Function display

When a FUNCTION button is depressed, the latest function used will be presented on the function display. If no function has been selected previously, the function "01" will be shown. If the FUNCTION and VALUE buttons are not activated for 5 s, the display will show "--".

Value display

The VALUE display shows the value for the selected function. If the FUNCTION and VALUE buttons are not activated for 5 s, the VALUE display will show the present status or error code for the operator.

Back

The function description on the back of the PMD is reversible. The green side is to be used when adjusting sliding doors and the blue side when adjusting swing doors.

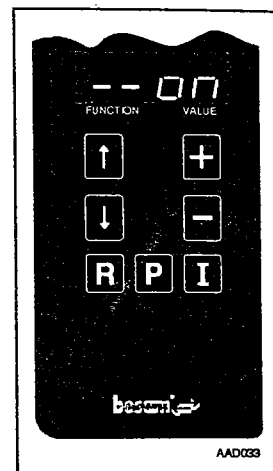







PMD – Program Selection

Program selector (blue push-button set to be used)

Buttons 1-4 control necessary functions of the operator. The PMD will override the settings of the program selector, if installed. The program selector will resume function about 30 seconds after the PMD is removed.

Settings

1.  "Off" The door is closed.
2.  "Exit" Exit only.
3.  "Open" The door is permanently open.
4.  "Auto" The door opens with inner and outer activation units.
5. **Mat** Mat safety impulse.
6. **VP (IFD)** Presence detection.
7.  "Key impulse" Key opening impulse.
8.  "Low speed opening" or "Learn" if VP-S is connected Push the button for 3 s. The door opens with pre-set low speed. Used to automatically adjust the sensitivity of the VP-S.
9.  "Door opening angle >99°" * Push the button for 3 s, then open the door to the required angle and close it by hand. The new angle is now programmed into the control unit.

* Operator mechanical stops may need adjustment.

Special Note: For surface applied Swingmaster MPs with reveals greater than 2", to achieve the desired angle, manually open the door slightly less (-4°) than required. E.G., if 90° is desired, push #9 for 3 seconds and open door to 86°, then close. When activated, door will open to 90°.

Pre-programmed run programs (Function 98)

Pre-programmed basic values for six different run programs (operating performance) can be selected with the function 98 and any of the values from 01 to 06. The value 98/03 is factory pre-programmed and selected to give a satisfactory function for most doors.

When selecting the values in the order from 01 to 06, the performance of the operator is gradually increased and can be adapted to the valid operating conditions. If the performance has to be increased depending on door size and/or door weight, never use a higher value than necessary. To comply with authority requirements, the value selected must give the operator a smooth and safe closing.

Programming the run programs into the control unit

1. Plug the PMD into the control unit on the operator.
2. Select function 98 and any of the values from 01 to 06.
3. Press the program button P within 5 seconds. The selected run program will now be transferred from the PMD to the control unit.

Note! The only values transferred will be values that affect the operator performance.

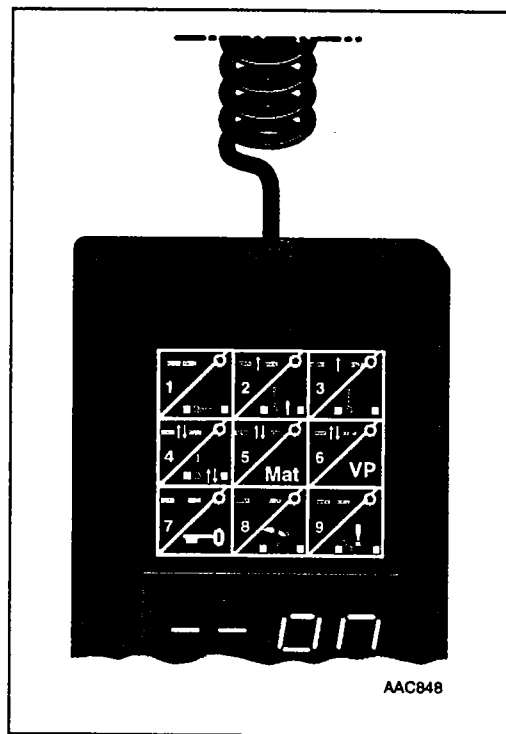

PMD – Push Button Set

Copying and transferring of programmed values (Function 98)

This function is used to facilitate the adjustment by copying and transferring the values from one smoothly running operator to another one with similar operating conditions. The values can be copied and transferred in two levels.

- Copying and transferring of user values only – Functions 01–27.
- Copying and transferring of all values.

Copying and transferring of user values only:

- Control Unit → PMD**
1. Plug the PMD into the control unit on the operator having the values to be copied.
 2. Select function **98** and value **99**.
 3. Press the program button **P** within 5 seconds. The user values only will now be transferred from the control unit to the PMD.

- PMD → Control Unit**
1. Plug the PMD into the control unit on the operator receiving the copied values.
 2. Select function **98** and value **98**.
 3. Press the program button **P** within 5 seconds. The user values will now be transferred from the PMD to the control unit on the new operator.

Copying and transferring of all values:

- Control Unit → PMD**
1. Plug the PMD into the control unit on the operator having the values to be copied.
 2. Select function **98** and value **97**.
 3. Press the program button **P** within 5 seconds. All programmed values will now be transferred from the control unit to the PMD.

- PMD → Control Unit**
1. Plug the PMD into the control unit on the operator receiving the copied values.
 2. Select function **98** and value **96**.
 3. Press the program button **P** within 5 seconds. All values will now be transferred from the PMD to the control unit on the new operator.

PMD – Functions And Values

Function	Description	Value	*)
01	High speed opening	15-90 %/s	45
02	Low speed opening	05-15 %/s	10
03	Low speed distance opening	05-40 °	20
04	High speed closing	15-60 %/s	25
05	Low speed closing	05-15 %/s	10
06	Low speed distance closing	05-30 °	20
07	Lock kick, additional	00-40 %/s	00
08	Hold open time	00-60 s	05
09	Key open time	00-60 s	05
10	Door opening angle ¹	30-99 °	70
11	Switch 1, angle ²	00-99°	10
12	Switch 2, angle ²	00-99°	60
13	VP-S swing side ³	A/b no/yes	A
14	VP-S approach side ³	A/b no/yes	A
15	Type of operator ⁴	00-99	00
16	Push Reactivation, PR ⁵	00-60 s	02
17	Presence impulse monitoring ⁶	00-20	20
18	Mat safety monitoring ⁶	00-20	20
19	Presence detection type, break/make impulse ⁷	A/b break/make	b
20	Overhead presence detection	A/b no/yes	A
21	Navig-Aider (SA/OHC)	00-01	00
22	Balance force, open door	00-40	24
23	Hold force, closed door ⁸	00-40	00
24	Locking without/with power ⁹	A/b w/o / w.	A
25	Opening delay for unlocking ¹⁰	00-50 x 0,1 s	00
26	Spring closing only	A/b no/yes	A
27	Door opening direction	A/b	A
28	Number of operator cycles performed x 10000	00-99	00
29	Number of operator cycles performed x 100	00-99	00
30	Change of PIN-code ¹¹	A/b no/yes	A
96	VP-S swing side, status ³	-9→.9	.F
97	VP-S approach side, status ³	-9→.9	.F
98	Run program ¹²	01-06	03
	Copying and transferring of values between operators ¹³	96-99	-
99	System tests ¹⁴	01-05	-

*) Factory pre-programmed values in the control unit.

- 1) To set angle >99°, see item 9, page 43.
- 2) Used for switching of the VP (IFD) detection fields.
- 3) Used if VP-S is installed on swing/approach side.
- 4) IK-A= 00; IKA-S=02
- 5) Value 00 = No PR. 01-60 s = Hold open time.
- 6) Value 00 = No monitoring, 01-20 = Monitoring. The control unit will monitor the VP-S (IFD) and/or the mat. After the set value of actuators (01-20) without a VP-S (IFD) /mat impulse, the door will stay open. Note: for trained traffic applications with no presence detection, this may be set to 00.

- 7) Used for switching between break or make impulse for terminal No. 5 on the CUP.
- 8) Selects an additional hold force for a closed door.
- 9) After changing always press the reset button R.
- 10) An impulsed operator signals a lock-release to unlock the striking plate.
- 11) See page 41.
- 12) Pre-programmed basic values for 6 different run programs can be selected (see page 43).
- 13) See page 44.
- 14) 5 functional tests can be performed (see page 52).

Wiring Options

Setting up the 3 position program switch kit.

The program switch has three functions (see page 39 for wiring and notes).

- "Off" The door is closed. The inner and outer activation units are disconnected. The electric lock, if equipped, is engaged. The door can only be opened with the key impulse. Push Reactivation, if selected, will still function if the door is not locked.
- "Auto" Normal position. The door can be opened with the inner and outer activation units and with key impulse. The electric lock, if equipped, is disengaged.
- "Open" The door is held open.

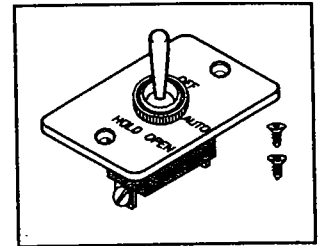

Setting up a 3 position program switch to deactivate Push Reactivation in the 'off' position.

Replace the kit-supplied SPDT switch with a DPDT (Double Pole, Double Throw) switch. Make connections to open the short between 6 and 7 on TB1. (See diagram at right.) The alternate kit label (Auto, Off, Hold Open) should be used.

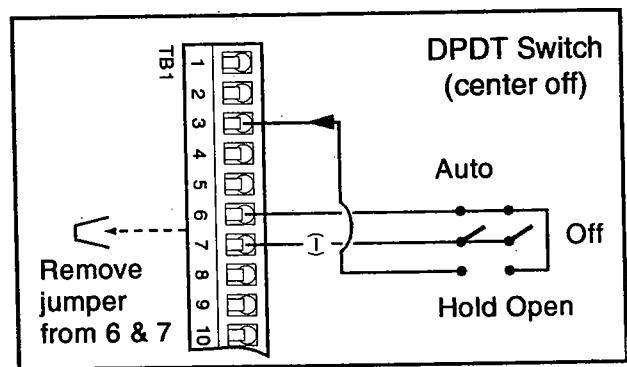

Wiring an electric strike and 4 position switch for Auto / Off / Hold Open / Exit functionality

- "Off" The door is closed. The inner and outer activation units are disconnected. The electric lock, if equipped, is engaged. The door can only be opened with the key impulse. Push Reactivation, if selected, will still function if the door is not locked.
- "Auto" Normal position. The door can be opened with the inner and outer activation units and with key impulse. The electric lock, if equipped, is disengaged.
- "Exit" One Way Traffic. The door is closed. It can be opened only with the inner activation units; the outer units are disconnected. The electric lock, if equipped, is engaged.
- "Open" The door is held open.

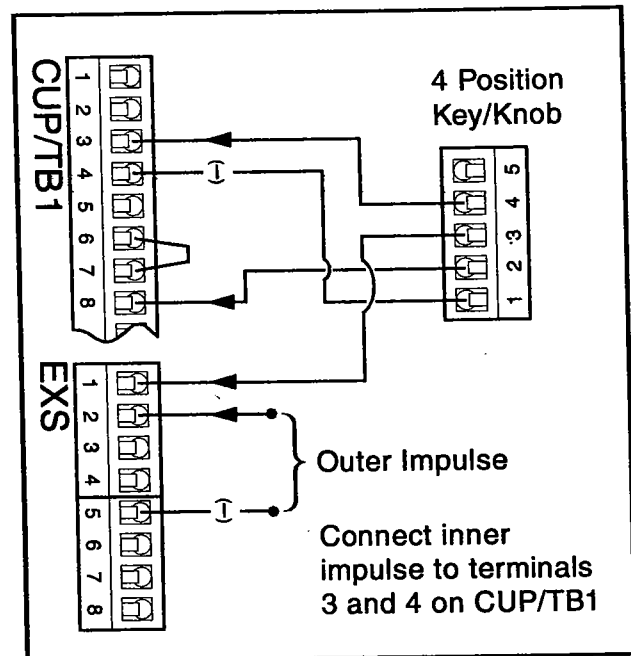

Wiring Options

Wiring and setting up the backup battery

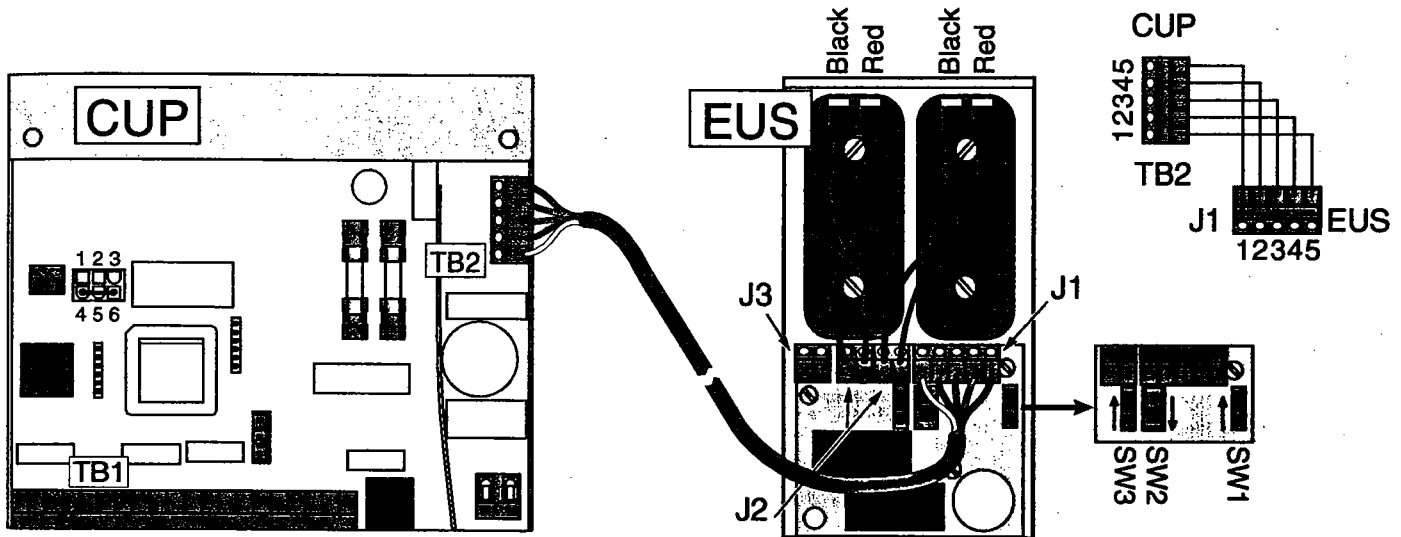

J1 connects to TB2 on the control unit. J2 is the terminal for the battery packs. J3 is not used.

Connecting the Radio Frequency (RF) remote control unit.

Place the receiver unit in the open space in the header.

Note! The single black wire at the bottom of the receiver unit is the antenna, and must not be confused with the power input black wire in the group of five wires at the top of the receiver unit.

Connect the power input (red and top black wires) of the receiver unit, red to terminal 19 on TB1 and black to terminal 20 on TB1. Connect the switch output (orange and brown wires), orange to terminal 3 on TB1 and brown to terminal 4 on TB1.

Arrange the antenna wire just inside the cover. For improved range, drill a small hole in the cover and run the antenna outside the case. Fasten the wire with silicone sealant and seal the end cover hole as well.

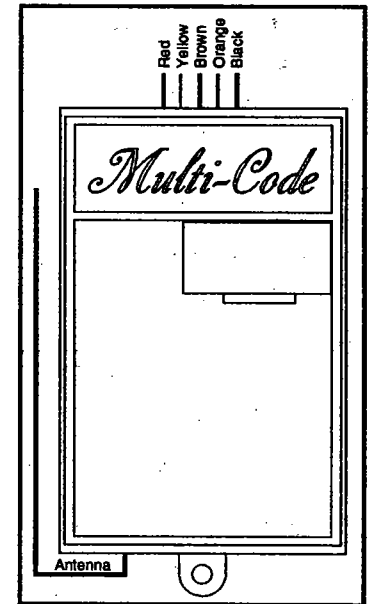

Using two pushplates, with different timing for each (e.g., normal and handicapped).

Wire a pushplate with a normally open switch to the key switch inputs (1 and 4), then use the PMD to program Function 09, "Key Operation", to a value other than 00 (e.g., 05 = 5 seconds of hold open time). See page 39 for standard pushplate connection.

Wiring Options – EXS Expansion Module

Installing the EXS:

Note: Before installing the EXS, take suitable static precautions, such as use of a grounding strap, to avoid damage to the EXS module or the control unit.

Hold the CUP control unit so that the main terminal block (TB1) faces forward. Hold the EXS so that its terminal block also faces forward. Insert the EXS connector pins into the corresponding pin blocks on the control unit, making sure that the pins are not offset from the pin blocks (see illustration).

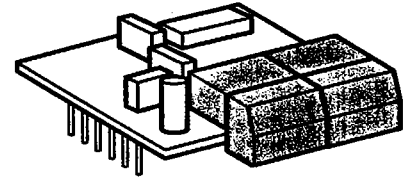

EXS terminals & functions

Terminal 1: EXIT ONLY – Selecting this function through the 4-position switch (see page 46) turns on the electric lock feature and prevents any device connected to Outer Impulse from opening the door. Inner Impulse devices, when activated, cause the lock to unlock and the door to open after a delay (adjustable from 0 to 5 seconds in 0.1 second increments through the PMD function 25). When the door reaches the fully closed position, the lock will relock.

Terminal 2: OUTER IMPULSE – For 2-way traffic applications, connect the exterior activating device (push plate, card reader, motion detector, etc.) to this terminal and one of the 0v (-) terminals (5 or 8).

Terminal 3: OPEN / CLOSE IMPULSE – This terminal allows a push to open / push to close function. A momentary push button is connected across 3 and a 0v (-) terminal (5 or 8). Pushing the button once opens the door and holds it open until the button is pushed again, which closes the door.

Terminal 4: INTERLOCKING "OUT" – This terminal, in conjunction with terminal #6, allows two doors to function in the manner of an "airlock". Each door will only open if the other door is fully closed. Control units must be synchronized - see pages 37 and 39.

Terminal 5: 0V DC – This is a DC ground point for the connection of various devices to the EXS.

Terminal 6: INTERLOCKING "IN" – (See terminal #4 above)

Terminal 7: 18V DC – This is an additional +18 volts DC connection point. It is in parallel with the 18 volt supply found on TB1 (terminal #19 and #20 of the CUP).

Terminal 8: 0V DC – This is a DC ground point for the connection of various devices to the EXS.

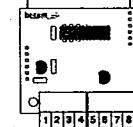
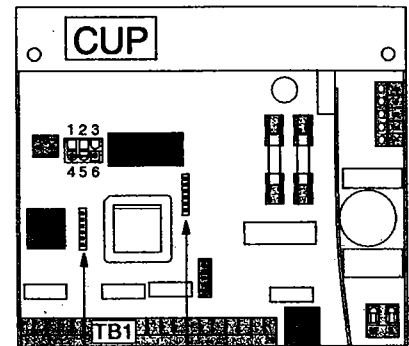

Caution: Use grounding strap when installing EXS.

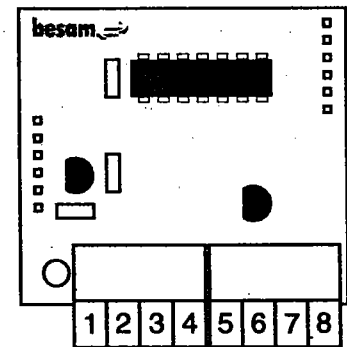

Sign Placement

ANSI/BHMA standard 156.10-1999 and Besam standards specify that caution signs must be affixed to both sides of any power operated door. The caution signs must be mounted at a height of 53 inches (± 5 inches from the floor to the center of the sign). In addition to the ANSI specifications, Besam strongly recommends that the full sign kit be applied to every installation, in the manner shown below:

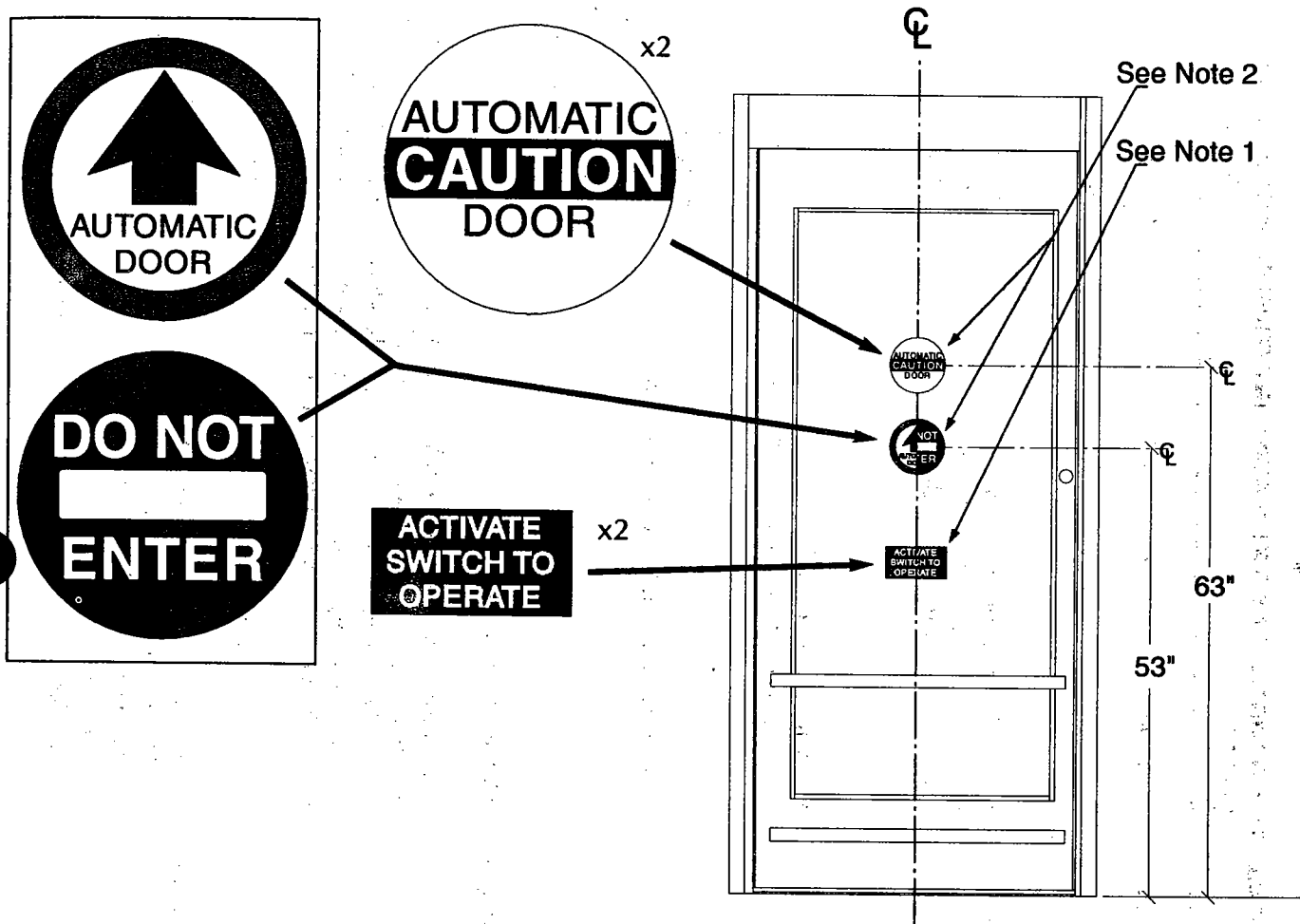

Notes:

1. When using a wall switch to activate the door, apply this decal to both sides of the door.
2. For all doors, the 'Automatic Caution Door' decal is applied to both sides. For one way doors, apply the 'Automatic Door' with arrow decal to the approach side, and the 'Do Not Enter' decal to the non-approach side. For two way doors, apply the 'Automatic Door' with arrow decal to both sides. See ANSI/BHMA excerpt on page 54.

Note – the circular kit decals are double-sided and normally will only need to be applied to one side of a clear glass door. If the decals are not clearly visible on the other side due to the condition of the glass (e.g., tinted or textured glass), the decals should be placed on both sides.

In a double door installation, signs should be applied to each door independently.

Troubleshooting

FAULT

CHECK

1. The door does not open-motor does not start.
 - Is there 120 VAC power at control box?
2. Control has power but still no operation.
 - Is On/Off/hold open switch set to off?
 - Is Push Reactivation properly selected?
 - Is push plate working (if used)?
 - Is motor power absent?
 - Are the two fuses on the control blown?
 - Do terminals 6 and 7 have jumper in place?
3. The motor starts but door does not open, or does not open properly.
 - Is the arm system loose?
 - Are the door hinges or arm binding anywhere?
 - Is there a door strike(electric) in the system?
 - Is spindle rotation correct for arm and door handing?
 - Have the settings been checked and do they conform to the recommended settings in the instructions?
 - Loose motor coupling.
 - Did you program the full open position?
 - Is the encoder plugged into the control?
 - Is the encoder, its wiring or the plug damaged?
 - Loose motor coupling.
 - Is the operator or the mechanical door stop adjusted?
4. The door does not open to the required angle.
 - Did you program the full open position with the PMD.
 - Plug it in to the proper socket.
 - Repair or replace as necessary.
 - Retighten.
 - Readjust.

FIX / REMEDIES

- Check/replace/reset main panel fuse or breaker.
Note: if it repeatedly trips, there is a short.
Check wiring from panel to control for an open circuit.
Note: there may be an in-line on/off wall switch.
- Change switch position to on.
- Select Push Reactivation
- Check push plate connections to control. Check for proper operation of push plate by using a multimeter to check for 0 ohms (when the switch is pressed) as measured at the control inputs.
- Check the motor cable plug on the control unit.
- Check with a multimeter for 0 ohms, and replace with a fuse of the same rating. Continued blowing of fuses suggests either a short, miswiring or lastly a bad control unit.
- This kill jumper must be closed for the control to operate. If an external kill switch is wired, temporarily short terminals 6 & 7; if the door now works, fix the external kill switch and wiring.
- Remove power, close door fully and adjust and tighten arm per installation instructions.
- Correct the binding condition.
- Check wiring and adjust strike.
- Check the instructions and correct if necessary.
- Connect the PMD and change settings to conform to recommended settings. Note that factory replacements are pre-programmed for the Swingmaster IK-A.
- Retighten.
- Set the full open position with the PMD.
- Plug it in to the proper socket.
- Repair or replace as necessary.
- Retighten.
- Readjust.

FAULT

CHECK

FIX / REMEDIES

- | | | |
|--|--|--|
| <p>5. The door does not open fully when impulsed during closing.</p> <p>6. The door opens more than to the adjusted angle.</p> <p>7. The door does not close, motor does not shut off.</p> <p>8. The door does not close fully.</p> <p>9. The motor and transformer get hot.</p> <p>10. No lights on the PMD.</p> <p>11. PMD will not communicate.</p> <p>12. PMD flashes an error code.</p> | <ul style="list-style-type: none">• Are the door hinges/pivots defective?• Is there binding in the door swing or arm system?• Are speeds and power levels set correctly?• Was the PMD based control adjusted properly?• Is the revolution counter disc defective or loose?• Is balance force "BF" too high?• Is there a shorted input signal?• Is the 3 way switch (if used) in hold open position?• Is the safety mat or the VP-S active?• Are the door or hinges binding?• Is the door arm binding or adjusted correctly?• Is there excessive draft or wind conditions?• Is the balance force "BF" set too high?• Is the hold force set too high?• Is power present?• Can you do anything with the PMD?• What is the code? | <ul style="list-style-type: none">• Replace and/or lubricate.• Repair/replace of re-align as necessary.• Retune control.• Use the PMD to adjust opening angle.• If loose try tightening, otherwise replace drive unit.• Check for excessive balance force (average = 24)• Correct the short.• Switch to on position.• Repair the safety mat or VP-S.
If the door still does not close, replace the control unit.• Repair or replace door or hinges.• Repair or readjust door arm.• Set 'spring closing only' to no. If needed, set hold force value to between 01-40 (40 is strongest).• Set lock kick value between 01-40 (40 is strongest).• Reset power. If door still does not operate properly, contact factory with CUP control serial number.• Readjust the balance force – see instructions.• Readjust the hold force – see instructions.• Check mains.• Check fuses• PMD properly connected.• Try second PMD.• Enter PIN code.• Turn power off, wait 1 minute then on again.• If you still cannot adjust, first try 2nd PMD, then a new control. <p>See charts on page 52 for explanation and correction.</p> |
|--|--|--|

© Copyright 3esam Automated Entrance Systems, Inc. May not be reprinted without permission.

PMD Codes, Tests and Status

PMD error codes.

Note that if more than one error code exists, correcting the first will let the second display, correcting the second will let the third display, and so on until all errors codes have been fixed.

Reason	Error Code	Remedies
Door opened without impulse	50 flashing	Check why the door moved.
Mat safety error	51 flashing	Check the contact mat.
Presence impulse error	52 flashing	Check the VP/VP-S and cables.
Motor error	53 flashing	Replace the motor.
Revolution counter error	54 flashing	Check revolution counter, cables.
Control unit error	55 flashing	Replace the control unit.
PMD error	69 flashing	Replace the PMD.
PMD-CUP communication error	70 flashing	Check the connections.
PMD access denied.	71 flashing	Return the PMD to be updated.

Testing with the PMD.

The PMD can initiate some system tests. Select function 99 and then enter the values shown below to specify a particular test. Press the program button P on the PMD to start the test. If the test is unsuccessful an error code will flash on the value display.

Value	Test Of	Error Code
01	External program selector switch	51 flashing
02	Motor, Visual test. (Let the door close before commencing this test.)	The motor runs about 1 second in the opening direction, then closes the door(s) again.
03	Revolution counter	54 flashing
04	Mat safety monitoring	51 flashing
05	Presence impulse monitoring	52 flashing

Status codes with the PMD.

The PMD normally shows the following status codes during operation. These status codes are not error codes. If any one of the status codes are constantly displayed during cycling, the corresponding input device has to be checked, and if necessary remedied or replaced.

Note!

If the fault persists and all the recommended measures have been taken, the operator and control must be returned well packed to the factory. Please include a written description of the problem with the unit being returned.

Status Code	Status	Remedies
on	Operation ok	Normal - everything is OK.
10	Search for closed position	Let the door finish its cycle.
11	Inner impulse active	Check this input.
12	Outer impulse active	Check this input.
13	Key impulse active	Check this input.
14	Synchronizing impulse active	Check this input.
15	Interlocking impulse active	Check the connections.
16	Mat safety active	Check this input.
17	Presence detection active	Check this input.
18	Presence impulse active	Check this input.
19	Door blocked	Check for obstacles
20	Kill impulse active	Check this input.
21	Low speed opening/Learn	Let the door finish its cycle.
22	Door opened with open/close impulse	Close the door with new impulse.

From American National Standard for power-operated pedestrian doors. Please refer to full standard if necessary, obtainable through BHMA at (212) 661-4261. All figures referred to below can be found in the full standard. Excerpts reprinted with BHMA permission.

Swinging Doors

Automatic Swing Doors have a variety of configurations, including:

A single door swinging in or out, left handed or right handed.

A pair of doors simultaneously swinging in the same direction

The door operator is concealed or surface applied. The doors are center pivoted, offset hung, balanced or butt hinged. No matter what the configuration or system, automatic swinging doors shall include guide rails, sensors, or control mats and signage for the safety and convenience of the user.

6.1 Guide Rails

6.1.1 Two guide rails shall be installed on the swing side of each door. Rails shall project at least to the leading edge of the widest door in the fully open position.

Exception #1: A wall or separator is permitted to be used in place of a rail, provided that it meets the criteria in 6.1.2 through 6.1.5.

Exception #2: Guide rails for swinging doors serving both egress and ingress shall project out from the face of the door jambs on the swing side to no less than the outside leading edge of the open door plus 55 in. (1400 mm). (See Figure A-2 & A-4.)

6.1.2 A guide rail shall be 30 inches (760 mm) high minimum, measured from the floor surface.

6.1.3 A guide rail shall have a panel or divider to inhibit access to the protected area.

6.1.4 There shall be 6 inches (150 mm) maximum clearance between the rail and the door in the fully open position or between the rail and the leading edge of the door at the point in its arc of travel when it is closest to the rail. There shall be a 2 inch (51 mm) minimum clearance between the rail at the hinge side and the door in the fully open position.

6.1.5 Free standing guide rails shall

have a maximum dimension between the rail and jamb (or other adjacent surface) of 2 inches (51 mm).

For control mat adjustments, see full standard.

Sensors

Motion sensors shall detect a 28 inch (710 mm) minimum high person or equivalent moving at a rate of 6 inches (150 mm) per second toward the center of the door within the detection areas described.

Presence sensors shall detect a stationary 28 inch (710 mm) minimum high person or equivalent within the detection areas described.

8.1 Swinging Doors

8.1.1 Non swing side activating detection areas shall have a minimum width equal to the width of the door opening less 5 inches (125 mm) maximum from both sides for a total of 10 inches (255 mm) maximum measured at 15 inches (380 mm) and 30 inches (760 mm) perpendicular from the face of the closed door. The length from the face of the door shall be 43 inches (1090 mm) minimum measured at the center of the door opening. Detection shall be effective to within 5 inches (125 mm) from the face of the door measured at the center of the door opening. (See Figure A-12A.)

8.1.2 A safety zone shall be provided on the swing side of all power operated swinging doors.

8.1.2.1 If an overhead sensor(s) is used to provide a safety zone, the length of the active area shall be effective to within 5 inches (125 mm) of the face of the closed door measured at the center of the door opening. The safety zone shall extend 5 inches (125 mm) minimum beyond the leading edge of the door in the open position when measured at the center of the door opening. The width of the active area measured perpendicular from the face of the closed door shall be the door opening less 5 inches (125 mm) maximum measuring both sides for a total of 10 inches (255 mm) maximum measured parallel to the face of the door at a distance of 15 inches (380 mm) and 30 inches (760 mm). (See Figure A-12A.)

8.1.2.2 If a door mounted sensor is used to provide a safety zone, it shall provide an active area 5 inches (125 mm) maximum from the face of the door for the width of the door less 5 inches (125 mm) from the pivot point. A door mounted sensor on either side of the door shall detect a

28 inch minimum (710 mm) high person or equivalent in the swing path during the opening or closing cycle, and shall cause the door to reverse direction, stop or slow down to a maximum latch edge speed of 4 inches per second (100 mm per second) measured within one inch (25 mm) of the latch edge before any contact is made. (See Figure 12B).

8.1.3 Swinging doors serving both egress and ingress shall have on the swing side a safety zone as defined in 8.1.2 and an activating zone extending an additional 55 inches (1400 mm) from the leading edge of the door in the open position. (See Figure A-12A.)

8.1.4 If a sensor is used for activation and a safety control mat is used as a safety zone, the exposed area of the safety control mat shall extend 5 inches (125 mm) minimum beyond the edge of the door in open position and:

1) extend 5 inches (125 mm) into the non swing side area of the door, measured from the face of the door; or

2) the door opening area shall be provided with a presence sensor which shall be used to prevent a fully open door(s) from closing when a person is in the space between two non overlapping activation or safety areas; or

3) the door closing cycle shall have a delay of 4 seconds minimum after the activating area is clear; or

4) be equipped with a door mounted sensor on the non swing side as described in 8.1.2.2.

8.1.4.1 The width of a safety control mat shall be in accordance with 7.3.1. (See Figure A-12A.)

8.1.5 When sensors are used to provide both an activation and a safety zone(s), if the distance between the two non-overlapping zones exceeds 8 inches (205 mm) the door system shall:

1) be equipped with a safety control mat; or

2) be equipped with a presence sensor across the door opening; or

3) have a door closing cycle delay of 4 seconds minimum after the activation area is clear; or

4) be equipped with a door mounted sensor on the non swing side as described in 8.1.2.2.

For Knowing Acts, see full standard.

10. Entrapment Protection

10.1 Entrapment protection measurements shall be taken under neutral air pressure conditions.

10.2 The force required to prevent a stopped power operated swinging door from moving in the direction of closing shall not exceed a 40 lbf (180 N) applied 1 inch (25 mm) from the lock edge of the door at any point in the closing cycle.

10.3 The opening time of a swinging or folding door to backcheck shall not be less than 1.5 seconds.

10.4 The force required to prevent a stopped power operated swinging door in the last 10 degrees of opening from moving in the direction of opening shall not exceed a 40 lbf (180 N) applied 1 inch (25 mm) from the lock edge of the door.

10.5 A door shall not close through the final 10 degrees for swinging doors or no less than 2 inches (51 mm) for folding doors in less than 1.5 seconds.

10.6 Swing, sliding and folding doors utilizing sensors or control mats shall remain open a minimum of 1.5 seconds after loss of detection.

10.7 A swinging door shall be adjusted so that closing time to latch check shall be the minimum values in the following table:

Inches (mm) (D)	Lbs. (kg) (W)	Time T (secs.)
36 (914) & under	to 100 (45)	2.0
36 (914)	to 140 (64)	2.3
42 (1067)	to 110 (50)	2.3
42 (1067)	to 150 (68)	2.7
48 (2119)	to 120 (55)	2.8
48 (2119)	to 160 (73)	3.2

For doors of other weights and widths:

$$T = D \sqrt{W} / 188 \text{ where:}$$

W = weight of door in pounds

D = width of door in inches

T = closing time to latch check in seconds.

For doors weighing more than 160 lbs (71 kg):

$$V = \sqrt{161 / W} \text{ where:}$$

V = Velocity in ft/sec

W = weight of door in pounds

10.8 Clearance. Center pivoted swinging and folding doors shall have provisions for finger guard protection if the door clearance at the hinge side is greater than 1/4 inch (6.4 mm) and less than 3/4 inch (19 mm) with the door in any position.

11. Signage

11.1 All swinging, sliding and folding doors shall be equipped with signage visible from both sides reading "AUTOMATIC DOOR" with letters 1/2 inch (12.7 mm) high minimum. The sign described in 11.2.3 shall be permitted to be used to satisfy this requirement.

11.2 Swinging Doors (See Figure B-3 & 4.)

11.2.1 An arrow sign (see Figure 1) shall be visible from the approach side of a swinging door mounted on the door at a height 58 inches \pm 5 inches (1475 \pm 125 mm) from the floor to center line of the sign. The sign shall be a minimum of 6 inches (150 mm) in diameter, having a green circle surrounding a black arrow on a white background.



Figure 1

11.2.2 An international "DO NOT ENTER" sign (see Figure 2) shall be visible from the side of doors that would swing or fold towards pedestrians attempting to travel in the wrong direction, mounted on the door at a height 58 inches \pm 5 inches (1475 \pm 125 mm) from the floor to center line of the sign. The sign shall be a minimum of 6 inches (150 mm) in diameter, having a red circle with the wording "DO NOT ENTER" in the red circle.



Figure 2

11.2.3 Swinging doors serving both egress and ingress shall be marked with a decal, visible from the swing side of the door, with the words "AUTOMATIC CAUTION DOOR" (see Figure 3). The sign shall be mounted on the door at a height 58 inches \pm 5 inches (1475 \pm 125 mm) from the floor to center line of the sign. The sign shall be a minimum of 6 inches (150 mm) in diameter and with black lettering on a yellow background.



Figure 3

12 General Performance

12.1 Latch Check. Latch check shall occur for swinging doors at no less than ten degrees from closed position and for sliding and folding doors at no less than 2 inches (51 mm) from the closed position.

12.2 Manual Opening Force for Swinging Doors. In the event of a power failure, the door shall be capable of opening with no greater than a 30 lbf (133 N), applied one inch (25 mm) from the edge of the lock stile.

12.3 Break Away Device for Swinging and Folding Doors. Swinging and folding doors provided with a break-away device shall require no more than a 50 lbf (222 N) applied 1 inch (25 mm) from the edge of the lock stile to open. When the door is opened in the break out mode, powered operating components, excluding spring power, shall not operate the door.

Door/Operator Handing

Door Handing (Automatic Door Industry)

Door handing is determined by standing with your back to the hinge. The side to which the door normally opens (right or left) is the handing of the door. The door is an inswing door if it opens to the inside and an outswing door if it opens to the outside. The diagram below shows a right-handed outswing door.

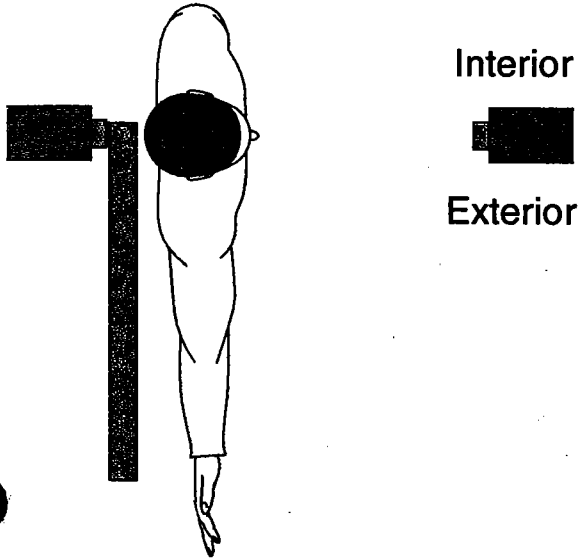

Operator Handing

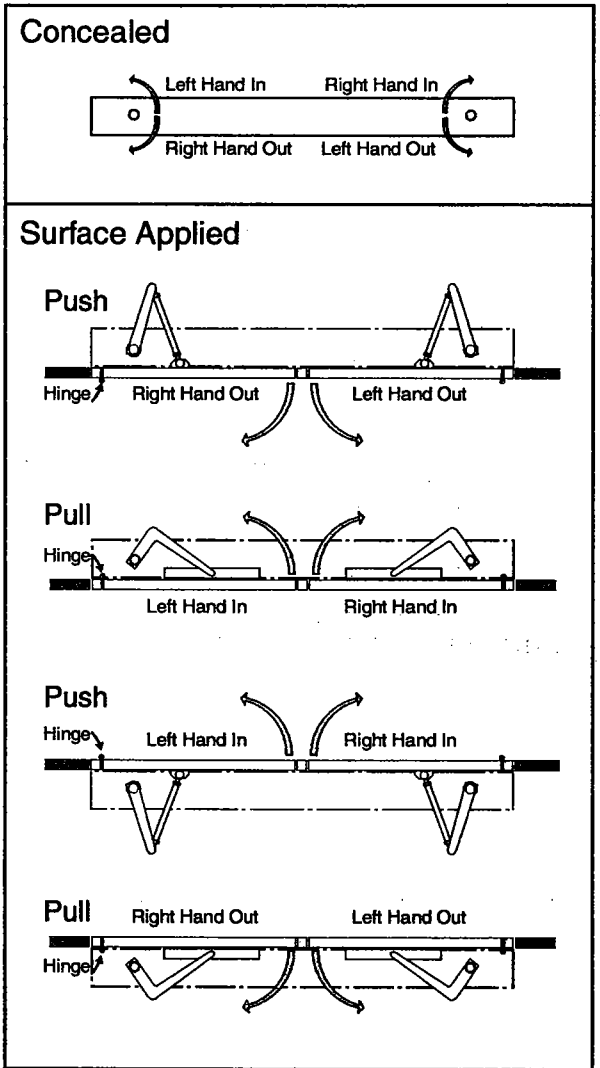

Door Handing (Architectural Hardware Industry)

You may occasionally see references to terms such as 'right hand reverse' or 'left hand reverse.' See diagram below for definition, paying particular attention to the location and placement of the hinge. Because of the varied hardware items applicable, a swing door type has to be identified by a specific hand. The hand of a door is always as viewed from the exterior side of a door.

Reverse designations apply to such hardware as rim type panic exit devices and latch locks which have a beveled latch for locking purposes on doors that swing out.

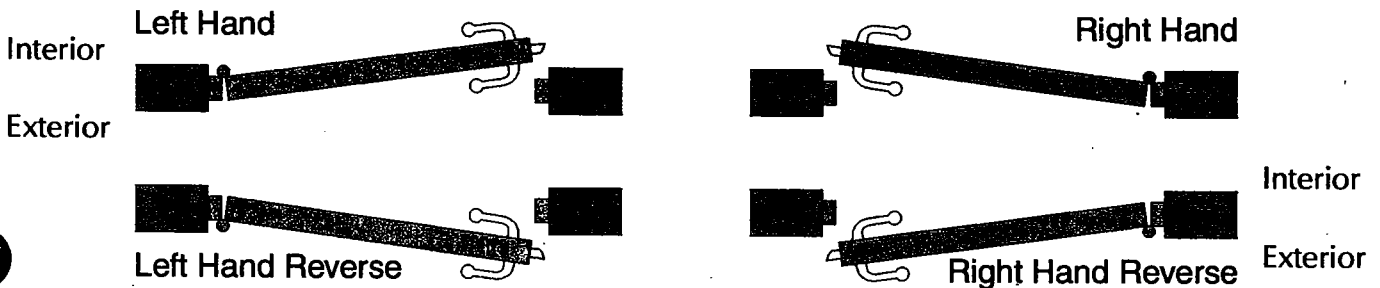

Frequently Asked Questions

Q. Why are the push arm shoe mounting holes not symmetrical?

A. By removing the arm shoe from the telescopic sleeve and turning the arm shoe upside down, the mechanical closing force is slightly modified. This can be used if your installation requires extra adjustment beyond the limits of the control unit. Care must be taken that this modification does not cause the door to exceed ANSI / BHMA requirements (see page 53).

Q. What will happen if I mount the surface-applied operator at a 'B' distance different than the one recommended?

A. It will alter the manual push open force. Mounting the operator closer to the hinge gives the operator less leverage (power) to open the door, and thus lowers the manual push open force. It also lowers the amount of spring force available to close the door and hold it closed. Mounting the operator further from the hinge has the opposite effect.

Note: Mounting the operator at any distance other than the recommended distance 'B' in this manual can damage the operator or exceed ANSI/BHMA requirements (see page 53).

Q. How can I adjust the operator to counteract high wind forces or high drafts?

A. Turn off Push & Go.

Increase close force

Increase hold force

Change to optional higher force spring tube (contact Besam for details). Be aware that this may cause higher manual forces, possibly exceeding safety standards. Check ANSI/BHMA and local code requirements.

Planned Maintenance Checklist

- Measure / Adjust Speeds – Measure to ANSI/BHMA A156.10 and local codes; adjust if necessary.
- Measure / Adjust Forces – Measure to ANSI/BHMA A156.10 and local codes; adjust if necessary.
- Measure / Adjust Time Delays – Measure to ANSI/BHMA A156.10 and adjust if necessary.
- Check Functioning – Mats, Sensors, Operator/Control, and Push Plates per device checklist and AAADM.
- Check Signage – Are all signs in place, readable, and in good condition?
- Check Door Hinging / Mechanical Soundness – all attachments, covers, arms, crash bars, etc.
- Check Finger Guards, Glass and Glass Stops, Trip Hazards, Rails, Sharp Edges
- Check Emergency Egress (if so equipped).
- Check all wiring for good connections, proper insulation and clearance from moving parts.
- Check Battery Backup if equipped.
- Go through Daily Safety Checklist with facility manager.

Parts List

P/N: 30-02-655449
P/N: 30-02-655630
P/N: 30-02-600126
P/N: 30-02-654745
P/N: 30-10-100092
P/N: 30-10-100106
P/N: 04-02-654509B
P/N: 04-02-654509C
P/N: 04-02-654509E

CUP Control Unit
EXS Board
EUS Battery Backup
Replacement Battery Pack for EUS (2)
Swingmaster MP Drive Unit – OHC
Swingmaster MP Drive Unit – Surface Applied
PMD, 2000 Use Service Life
PMD, 400 Use Service Life
PMD, Restricted Customer Version, 400 Use Service Life

Arm Systems:

P/N: 30-06-102
P/N: 30-06-217
P/N: 30-06-103
P/N: 30-06-226
P/N: 30-06-104
P/N: 30-06-215
P/N: 30-06-101

Pushing Arm, NAS – Clear
Pushing Arm, NAS – Black
Pulling Arm, Right Hand, PAS – Clear
Pulling Arm, Right Hand, PAS – Black
Pulling Arm, Left Hand, PAS – Clear
Pulling Arm, Left Hand, PAS – Black
Concealed Arm
(See pages 60-61 for optimal arm extension parts)

Kits:

P/N: 50-15-114
P/N: 30-15-228
P/N: 30-15-245
P/N: 30-15-246
P/N: 75-15-310
P/N: 75-15-311
P/N: 75-15-100
P/N: 75-15-101
P/N: 75-15-105
P/N: 75-15-106

Spacer Kit for Concealed Arm
Surface Applied Drive Shaft Extension Kit – 1-3/4"
Surface Applied Drive Shaft Extension Kit – 3-1/2"
Surface Applied Drive Shaft Extension Kit – 5"
3 Position Switch – Clear
3 Position Switch – Black
4 Position Switch – Knob – Clear
4 Position Switch – Knob – Black
4 Position Switch – Key – Clear
4 Position Switch – Key – Black

Labels:

P/N: 75-20-100
P/N: 75-20-101
P/N: 75-20-102

Dual Side "Automatic Door / Do Not Enter" – (Out)
Dual Side "Automatic Door / Do Not Enter" – (In)
Dual Side "Caution Automatic Door"

Push Plates:

P/N: US02-0153-02
P/N: US02-0153-04
P/N: 75-02-100
P/N: 75-02-104
P/N: 75-02-281
P/N: 75-21-002

Square: "Push To Open"
Square: Blank
Round: "Push To Open"
Round: Blank
Narrow: "Push To Open"
Installation Box for Narrow plates

Remote Push Plates (RF):

P/N: 75-02-269
P/N: 75-02-273
P/N: 75-02-271

Narrow: "Push To Open"
Round: "Push To Open"
Remote Receiver

Outswing Arm Assembly

- (1) Outswing Arm
- (2) Shaft Adapter
- (3) Shaft Adapter Lock
- (4) SM6 Male Rod Ends (2)
- (5) Connecting Rod 10-1/4 (Std.)
- (6) Door Bracket
- (7) 7/16" 20x1-1/4" S.H.C.S. (P)
- (8) 3/8" 24x3/4" F.H.(S.H.)M.S. (P)
- (9) 3/8" 16x1-1/2" F.H.(S.H.)M.S. (P)
- (10) 3/8" 16x1-1/4" Hex Head Bolt (P)
- (11) 3/8" 16 Lock Nuts (P) (2)
- (12) 3/8" 24 Jamb Nuts (P) (2)
- (13) 1/4" 20x1" R.H.P.M.S. (P) (2)
- (14) A25-151 C'SK. Rivnuts (2)

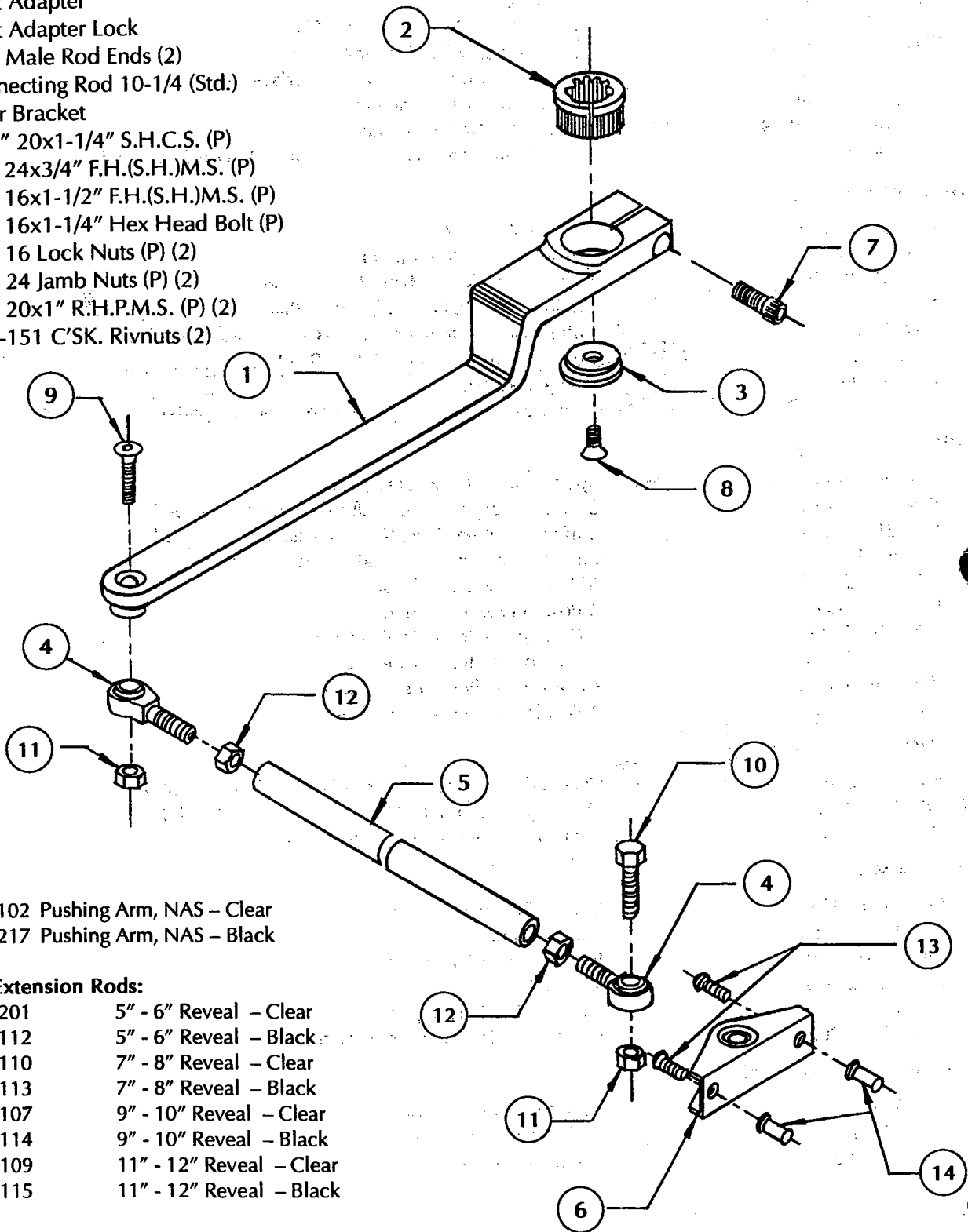

P/N: 30-06-102 Pushing Arm, NAS – Clear
 P/N: 30-06-217 Pushing Arm, NAS – Black

Push Arm Extension Rods:

- P/N: 30-06-201 5" - 6" Reveal – Clear
- P/N: 30-06-112 5" - 6" Reveal – Black
- P/N: 30-06-110 7" - 8" Reveal – Clear
- P/N: 30-06-113 7" - 8" Reveal – Black
- P/N: 30-06-107 9" - 10" Reveal – Clear
- P/N: 30-06-114 9" - 10" Reveal – Black
- P/N: 30-06-109 11" - 12" Reveal – Clear
- P/N: 30-06-115 11" - 12" Reveal – Black

Inswing Arm Assembly

P/N: 30-06-103 Pulling Arm, Right Hand, PAS – Clear
 P/N: 30-06-226 Pulling Arm, Right Hand, PAS – Black
 P/N: 30-06-104 Pulling Arm, Left Hand, PAS – Clear
 P/N: 30-06-215 Pulling Arm, Left Hand, PAS – Black

- (1) Inswing Arm (Left Hand shown; Right Hand reverse)
- (2) Shaft Adapter
- (3) Shaft Adapter Lock
- (4) Roller Shaft
- (5) Plastic Thrust Washer (2)
- (6) Inswing Roller
- (7) Inswing Track (15" Standard)

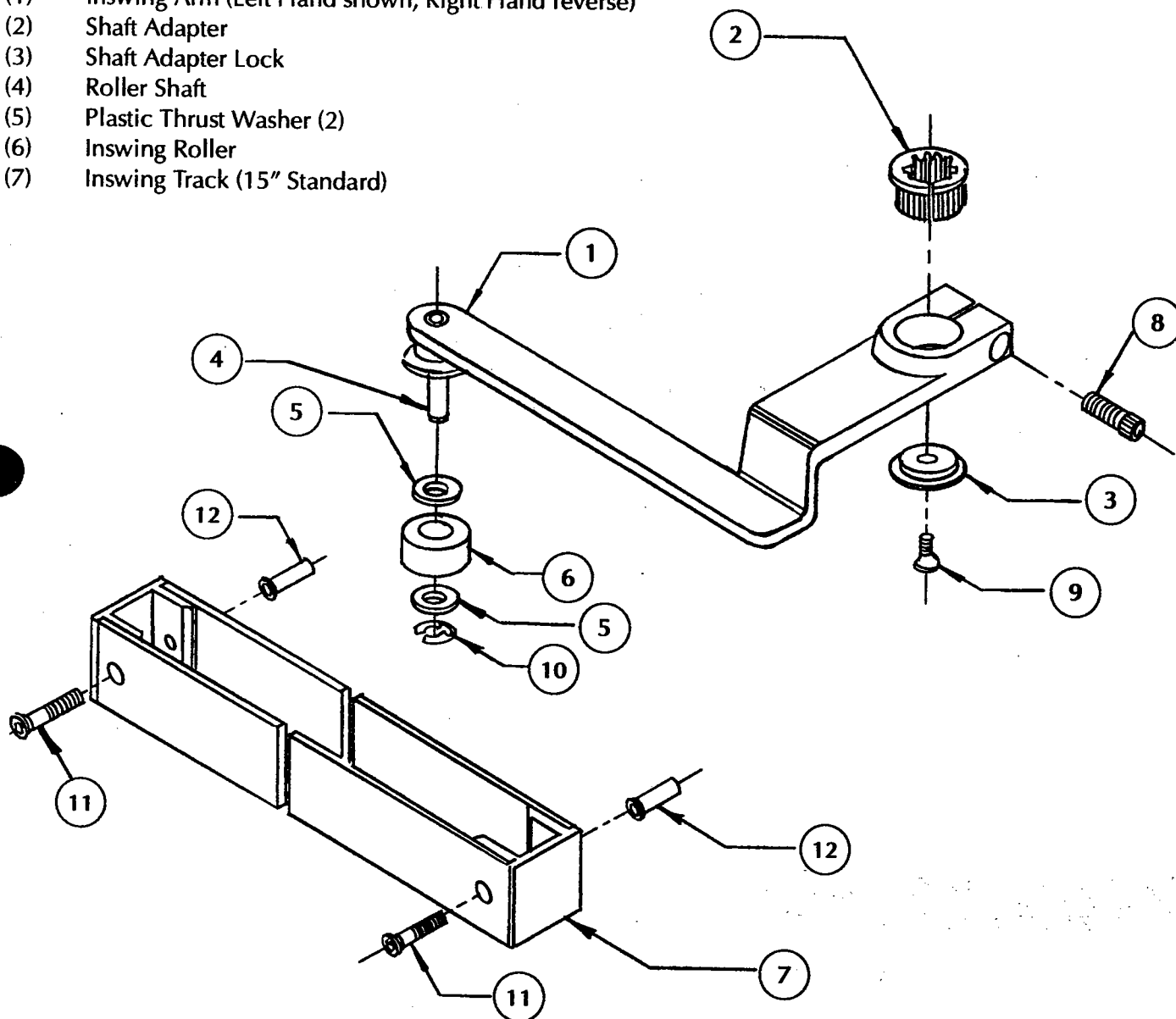

- (8) 7/16" 20x1-1/4" S.H.C.S. (P)
- (9) 3/8" 24x3/4" F.H.(S.H.)M.S. (P)
- (10) #5304-43 Retaining Ring
- (11) 1/4" 20x2-1/4" F.H.P.M.S. (P) (2)
- (12) A25-140 Rivnuts - Flat Head (2)

P/N: 30-06-241 20" Track – Clear
 P/N: 30-06-242 20" Track – Black
 P/N: 30-06-243 24" Track – Clear
 P/N: 30-06-244 24" Track – Black



Automated Entrance Systems, Inc.

84 Twin Rivers Drive
Hightstown, New Jersey
08520-5213
USA

Tel: 800-872-9290
609-443-5800

Fax: 609-443-6167

Web: <http://www.besam.com/na/>

E-mail: marketing@besam-usa.com

Besam Support Services

For 24 hour-a-day service, contact 1-800-95BESAM

Besam follows a policy of advancements in development.
For this reason, specifications may be changed without notice.

© Copyright 2000 Besam Automated Entrance Systems, Inc.
Printed in USA