



Installation and Operating Manual

TTXII Swing Door Operator

Contents

1	Introduction	3
2	Safety	4
2.1	General Safety and Accident Prevention Regulations	4
2.2	Safeguarding Danger Points	5
2.3	Organizational Measures	6
3	Basic Functions	7 - 8
4	Installation	
	Outswing Surface Mount With 0" to 9 -7/8" Reveal	9
	Inswing Surface Mount With 0" Reveal	10
	Inswing Surface Mount With Deep Reveal	11
	Double Egress with Surface Mount	12
5	Mechanical Adjustments	13
6	Electrical Connections and Wiring Diagrams	14 - 14g
7	Commissioning and Adjustments	
7.1	Commissioning with "Teach-In General"	15
7.2	Programming Examples	16
7.3	Programming Table	17
7.4	Programming Functions	18 - 19
7.5	Simultaneous or Double Egress Programming	20 - 21
8	Trouble Shooting	22

First edition: 9.02 provisional for 0-Series

Update: 3.03, 8.04, 1.09

We print on environment-friendly paper bleached without chlorine.

The enterprises Landert Motoren AG and Landert GmbH are certified according to ISO 9001.

1 Introduction

Adressee

These instructions are addressed to AAADM Certified installation and service technicians.

Area of Application

This document is applicable to the Tormax TTXII swing door operator with SW 1.4 and up.

Explanation of Symbols



Non-compliance endangers the safety of the installation personnel, the system operator or the user.



Warning of electrical voltage.

Passages with text on grey background must be absolutely observed for reliable performance of the system! Neglect can cause material damages.

2 Safety

2.1 General Safety and Accident Prevention Regulations

General safety Instructions



Prior to installation or commissioning, read and follow this information that is being described on this page—especially the following notes relating to safety—and adhere to them at all times! Damage to the unit and personal injury may result if these instructions were not carefully followed.

Pay particular attention to the specially marked notes in this manual (for an explanation of the symbols please refer to chapter 1)!

These products are Underwriters Laboratories, Inc. (UL) listed and cUL certified for the Canadian marketplace, and therefore comply with the requirements of the National Electrical Code (NEC) and the Canadian Electrical Code (CEC). Installations intended to meet UL and cUL requirements must be followed as described in the instruction provided herein. These are minimum standard requirements. Where local codes exceed these requirements, they must be followed as well.

Preventing General Hazards and Possible Damage to This Equipment

- Keep fingers away from all moving parts.
- Verify that the power selection switch is set to the correct voltage before start-up.
- The power supply cable (flexible cord) should be entered at the end side that is close to the input power supply plug. It should not be routed through doorways, window openings, walls, ceilings, floors, etc. The power supply cable (flexible cord) should not be attached or otherwise secured to the building structure. It should not also be concealed behind walls, etc.
- Never allow the power supply cable (flexible cord) to become entrapped in moving parts of the operator, door, or system.
- The power receptacle must be of the grounding-type. It is very important that the unit will be properly grounded.
- Proper grounding methods has to employed to reduce magnitude of transient over Voltage, To Simplify ground fault location, To improve system and equipment fault protection, To reduce maintainence time and expense and greater safety for personnel.
- Installer should do permanent wiring as required by the local codes.

Warnings of Dangerous Electrical Voltages or Current

- Be sure the electrical power is disconnected and locked-out when working on the operator unit.
- Install the electrical cables and power only after the mechanical installation to the unit is done.
- Turn on the power to the operator unit only after all internal cables are connected. Do not connect cables while the unit is powered.
- Always use appropriate tools for installation and repair.

Prior to commissioning or performing any work on the door system, the operating instructions for the TORMAX operator and the following safety directions should be studied with great care and must be observed!

Intended Purpose

The TORMAX operator is designed according to the current state of technology as well as the recognized safety-relevant regulations and is intended exclusively for the deployment in conjunction with automatic interior and exterior doors (without wind loads) used by people e.g. in hospitals, homes for the elderly, shopping centres, office buildings and large-scale enterprises. The operator corresponds to protective class IP 22. Without additional safety precautions, it may only be installed within, i.e. at the inside, of buildings.

Any other use or any use exceeding this aim is determined to be not for its intended purpose and may lead to personal injury to the user or a third party. Furthermore, the system or other material assets can be damaged. The manufacturer will not be responsible for any damage resulting from this; the risk is carried entirely by the operator of the door system.

The operating, service and maintenance conditions specified by the manufacturer are to be maintained. The persons entrusted with the service and maintenance must be acquainted with the matter and informed about any possible danger.

Maximum Door Leaf Weights



To ensure a reliable function of the door the moment of friction caused by e.g. bad aligning of door leaves or wind charge may not exceed 5 Nm.



In addition to the operating instructions, the legal and other obligatory regulations for accident prevention and environmental protection, in the respective country where the door system is operated, shall be applicable. The special directives for automatic doors (e.g. of the European committee for standardization CEN) must be adhered to. Furthermore, the operational/national regulations apply.

Arbitrary changes to the system will exempt the manufacturer from any liability for damages resulting from this.

2.2 Safeguarding Danger Points

General

DIN V 18650-2: 2003

Automatic door systems are to be constructed in such a manner that on opening and closing motions endangerments through jamming, shearing and drawing-in are avoided or safeguarded against, for example through:

- Safety separations
- Limitation of the door-leaf forces
- Monitored safety facilities
- Separating protective facilities

ANSI Compliance

- Always inspect your adjustments to be ANSI A156.10 or A156.19 compliant before handing over to the enduser.

2.3 Organizational Measures

Requirements for Installation or Service Technicians -

The installation or service should be made by an AAADM Certified technician in accordance with the latest ANSI A156.10 or A156.19 standard.

Contact Tormax for training classes conducted at our facility if you wish to attend a factory training class.

Fundamental Safety Measures – Appropriate Behaviour -



- Use the system only in a technically sound state. Eliminate faults immediately that may impair safety.
- Keep fingers away from any mobile parts. Special caution is required in the area of the drive lever, the linkage and the secondary closing edges of the hinges.
- Use exclusively tools that are suitable for the respective work procedure. Pay attention to good condition of the tools.
- Electric voltage/current: The operator is to be disconnected from electrical mains before any work is performed on electrical parts. Install cabling only after the installation is complete. Plug in the power plug only after all internal cables are connected.

3 Basic Functions

Motion Control – General

The door opens motor-driven in accordance with the stored speed profile (see section 7.1) against the installed spring. If the motor torque decreases the door is braked down by the spring. The door is held in the open position by a reduced motor torque. The closing action is performed through spring force only. Thereby, the motor adjusts the speed. At the completion of the closing motion, deceleration occurs with adjustable homing in speed over an adjustable angle (see section 7.4.2). The motor is switched off when the door is closed.

Functionality of the unit

Activator (4 - 5)	Opens the door in operating mode AUTO in accordance with “Teach-In General”.
Key Switch (7 - 8)	Opens the door in operating mode AUTO and in operating mode OFF in accordance with “Teach-In General”, or with “Teach-In Key Switch” if this was performed after “Teach-In General”.
“Push / Pull”	Opens the door in AUTOMATIC mode according to the “Teach-In General” instructions when the door is manually pushed open to an adjustable angle. “Push-and-Go” can be switched off.
“Push-and-Close”	When the open door (operating mode OPEN, during hold-open time, step control) is moved manually and considerably (16 °) in closing direction, it will close automatically.
Safety Device on Pull / Swing side (14 - 15 NC)	This prevents the door from opening if closed, cancels the opening cycle or If both the safety device in opening direction and the safety device in closing direction, respond at the same time during a motion, the door stops in place. Through “Teach-In General”, the safety sensor is disabled automatically – if necessary – over a predetermined door swing range. If this function is not used, a jumper is inserted between 14–15.
Safety device in closing direction/safety device for the swing area. (18 - 19 NC)	Standard function: Safety device in closing direction reactivates the door if the sensor becomes active. If the door reaches the full closed position the input is inhibited and can be used manually w/o activation. The input becomes active after another activation command is given. Optional functions: Safety device for the swing area The input keeps a closed door closed and an open door open. Safety Device Bodyguard This function is only in use with the safety device “Bodyguard” of BEA. The door remains open or closed. A commenced motion is completed. Using this function automatically changes the settings of Feedback Door State to “door opening or door open” data for the LO21 / LO21P lock out relay. If these safety functions are not used, a jumper is inserted between 18–19.
Test of safety devices	Output for active testing of the safety device in opening direction and safety device in closing direction (i.e. BEA Superscan or Bircher Topscan).
Operating Mode OFF	An opening can only be initiated through the key switch. Switching to operating mode OFF interrupts any current hold-open time.

Operating Mode AUTO An opening can be initiated by an activator, a key switch and also by "Push and Go" depending upon configuration.

Operating Mode OPEN The door opens and stops in open position. It opens according to the settings of "Teach-In General".

Door Lock Unlocks on each opening command. On completion of the opening time delay, the door starts opening. When the door has moved somewhat in opening direction, the door lock drops off again. The door lock is activated only in proximity of the "door closed" position.

Feedback Door State (door position) The feedback "door closed" (or "door open" if reconfigured) between 11–12 is only valid as long as mains supply is available. This message is established as soon as the processor considers the driving function as complete. Connection for 24 VDC relay or signal light. Transistor output short circuit proof in relation to internal supply voltage 24 VDC / 0.75 A.
If a second opening width has been configured ("Teach-In key switch") the feedback "door open" is as follows:

Triggering of opening	Feedback defined by
Activator	"Teach-In General"
Key-switch	"Teach-In key-switch"
"Push-and-Go"	"Teach-In General"
Manual operation	the smaller of both opening widths

Power Supply 24 VDC The control provides .75 amps total to the sensors and the lock output. If the control is over loaded the led point may start to flicker, go dim or completely turn off. If this occurs install an aux power supply to power up your accessories.

Reversing Motion (Reverse on Obstruction) If the door hits a firm obstacle during opening, the motor driven opening procedure is terminated immediately. If the door hits an obstacle during closing, it opens again waits for the safety time to elapse and tries to close again. The next opening command opens the door again as usual. If reversing is switched off, the door stays on the obstacle when closed. On opening after 60 seconds, the powered opening procedure stops.

Time Control The door opens when an impulse is received (key-switch, activator or "Push-and-Go"), remains in the valid open position during the valid hold-open time, and closes thereafter again.

Step Control The door opens when an impulse is received (from the key switch, activator or "Push-and-Go") and remains in the open position. The door closes immediately after the next impulse or "Push-and-Close". The motional sequence depends on the settings of the respective "Teach-In".

Internal Protective Devices The motor is switched off immediately when the door is blocked. Motor and transformer contain thermal relays that interrupt the current supply to the control system at 230 °F. The system operates as during a power failure until the temperature drops to 185 °F.

Power Failure The door can be manually opened if the door lock can be unlocked with the door handle. The door closes through spring force. The motor, which is controlled short-circuited, controls the closing action with constant braking power. After return of power, the system is immediately ready for use again.

4 Installation

INSTALLATION STEPS:
 1. LOCATE TT XII WITH DIMENSIONS SHOWN SO THAT UNIT IS LEVEL. IT MAY BE NECESSARY TO SPACE THE UNIT AWAY FROM WALL WITH PROPER SHIM MATERIAL (AS SHOWN), USE ALL MOUNTING HOLES PROVIDED, WITH CORRECT ANCHORS.

2. REMOVE PROTECTIVE STRIP FROM ENCODER AND CONNECT POWER, **PLACE UNIT INTO HOLD OPEN ONCE MOTOR HAS ROTATED APPROX. 20 DEG INSTALL OUTPUT SHAFT WITH SURFACES A & B RUNNING PARALLEL WITH EACH OTHER AND TORQUE OUTPUT SHAFT TO 30 FT. - LBS.**

3. CONNECT DRIVE ARM OPERATOR PORTION TO OUTPUT SHAFT AS SHOWN. MOUNT DOOR PORTION AS REQUIRED AND ADJUST LENGTH TO KEEP DOOR IN THE CLOSED POSITION.

4. PLACE UNIT INTO AUTO AND SEE SECTION 7 (COMMISSIONING THE TT X - II OPERATOR)

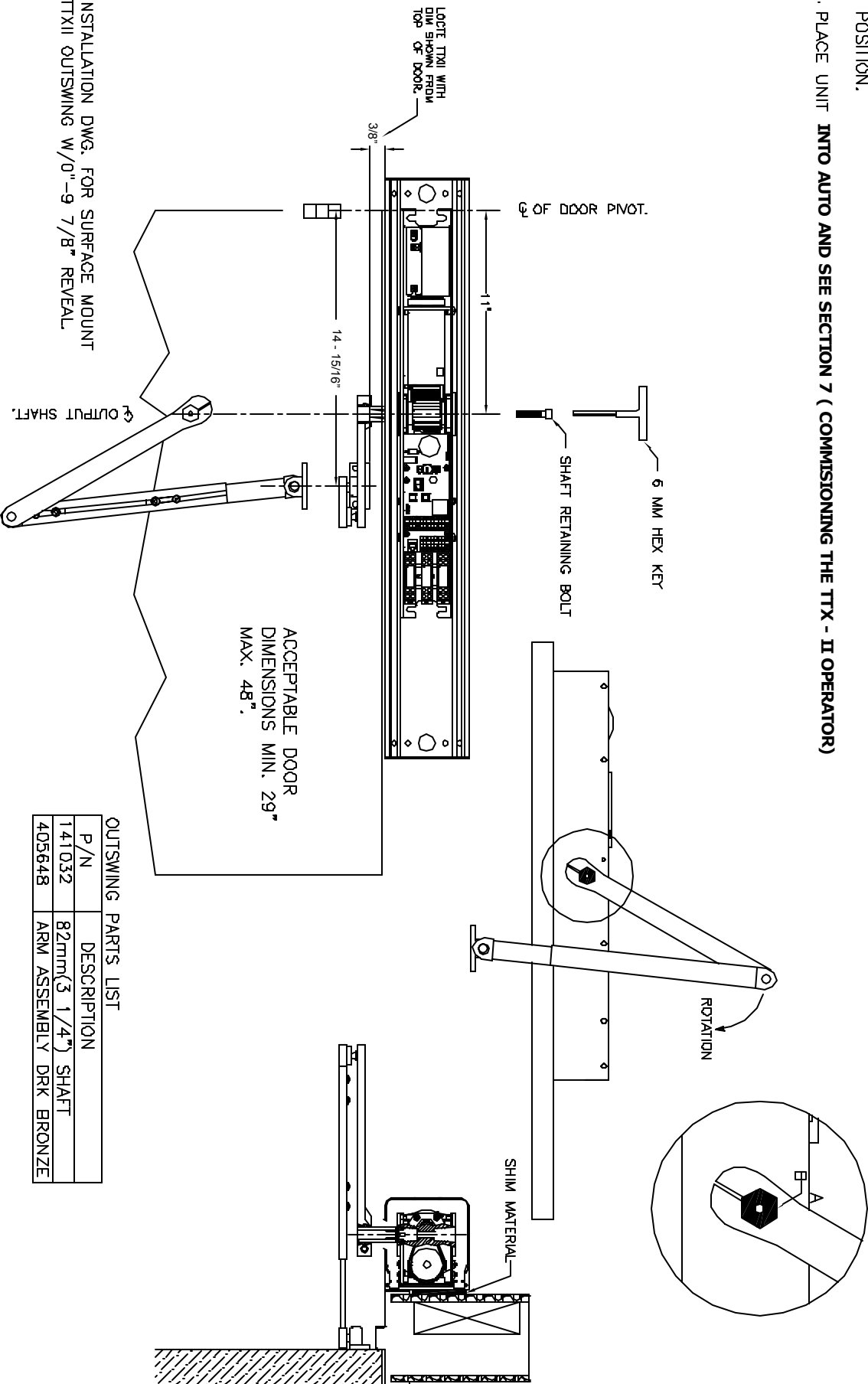

INSTALLATION DWG. FOR SURFACE MOUNT
 TT XII OUTSWING W/0"-9 7/8" REVEAL.

OUTSWING PARTS LIST

P/N	DESCRIPTION
141032	82mm(3 1/4") SHAFT
405648	ARM ASSEMBLY DRK BRONZE

1. INSTALLATION STEPS:
LOCATE TT XII WITH DIMENSIONS SHOWN SO THAT UNIT IS LEVEL. IT MAY BE NECESSARY TO SPACE THE UNIT AWAY FROM THE WALL WITH PROPER SHIM MATERIAL (AS SHOWN). USE ALL MOUNTING HOLES PROVIDED, WITH CORRECT ANCHORS.
2. MOUNT SLIDE TRACK WITH DIMENSIONS SHOWN. TRACK MUST BE PARALLEL TO TT XII UNIT & MOUNTED AS CLOSE TO TOP OF DOOR AS POSS. USE ALL PROVIDED MOUNTING LOCATIONS. SLIDE FASTENER COVER INTO PLACE.
3. INSTALL SLIDE ONTO TRACK WITH SLOTTED SIDE OF COVER FACING UP. SLICE SHOULD MOVE SMOOTHLY IN TRACK. INSTALL TRACK END CAPS.
4. INSTALL DRIVE ARM INTO SLIDE FIRST, THEN PLACE OUTPUT SHAFT & ARM INTO TT XII. INSTALL OUTPUT SHAFT RETAINING BOLT LOOSELY INTO OUTPUT SHAFT FROM OPPOSITE SIDE OF TT XII (AS SHOWN).

5. REMOVE PROTECTIVE STRIP FROM ENCODER, CONNECT POWER, **PLACE UNIT INTO HOLD OPEN FOR PRELOADING**
6. TIGHTEN DRIVE ARM TO OUTPUT SHAFT, THEN RETAINING BOLT TO OUTPUT SHAFT.
7. PLACE UNIT INTO AUTO AND SEE SECTION 7 (COMMISSIONING THE TTX - II OPERATOR)

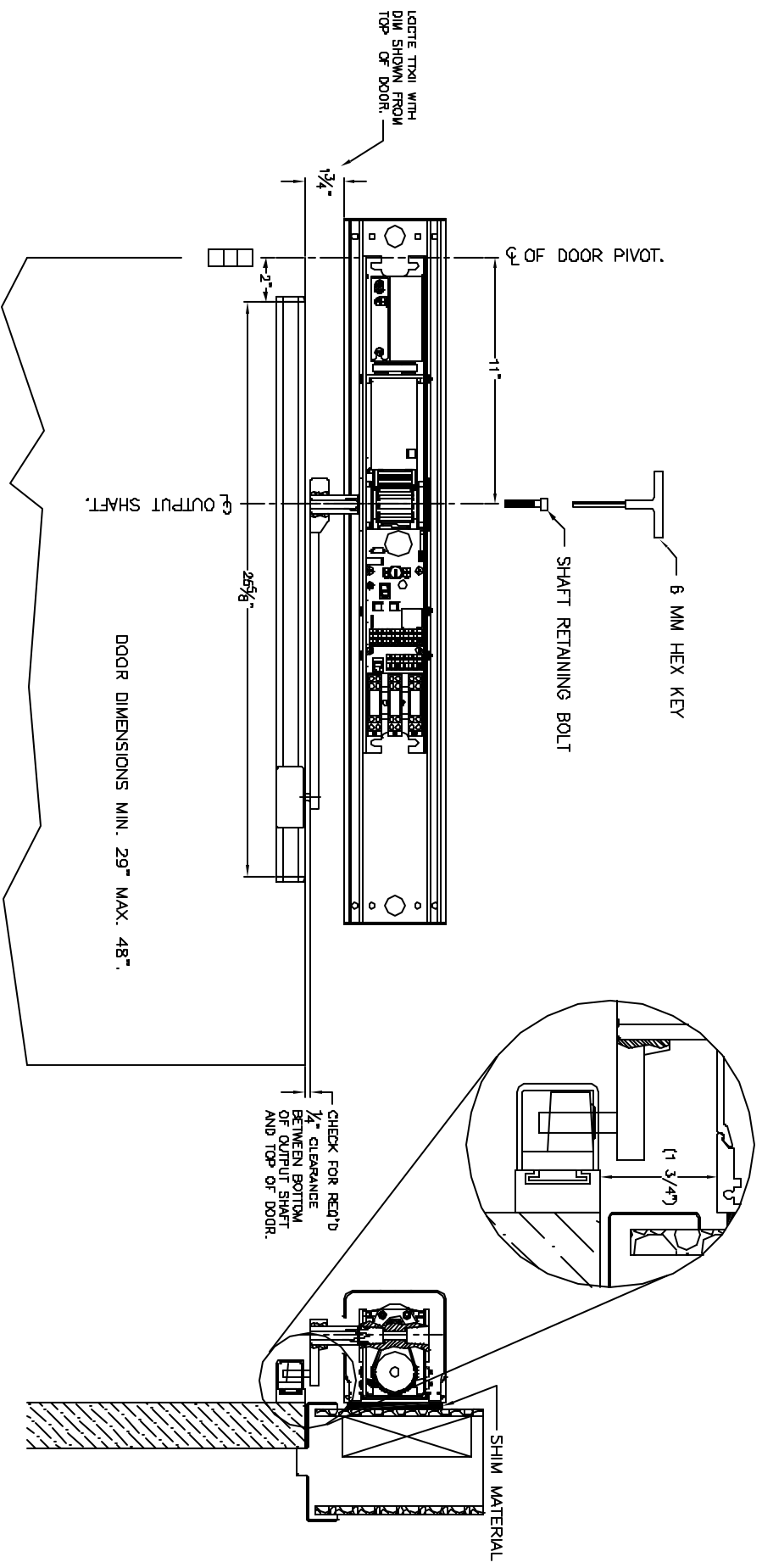

DOOR DIMENSIONS MIN. 29" MAX. 48"

INSWING PARTS LIST

P/N	DESCRIPTION
141032	82mm(3.22") SHAFT
405065	INSWING ARM DRK BRONZE

INSTALLATION DWG. FOR SURFACE MOUNT
TT XII INSWING W/0" REVEAL.

- INSTALLATION STEPS:
1. LOCATE TT XII WITH DIMENSIONS SHOWN SO THAT UNIT IS LEVEL. IT MAY BE NECESSARY TO SPACE THE UNIT AWAY FROM WALL WITH PROPER SHIM MATERIAL (AS SHOWN). USE ALL MOUNTING HOLES PROVIDED, WITH CORRECT ANCHORS.
 2. MOUNT SLIDE TRACK WITH DIMENSIONS SHOWN. TRACK MUST BE PARALLEL TO TT XII UNIT & MOUNTED AS CLOSE TO TOP OF DOOR AS POSS. USE ALL PROVIDED MOUNTING LOCATIONS. SLIDE FASTENER COVER INTO PLACE.
 3. INSTALL SLIDE ONTO TRACK WITH SLOTTED SIDE OF COVER FACING UP. SLIDE SHOULD MOVE SMOOTHLY IN TRACK. INSTALL TRACK END CAPS.
 4. INSTALL DRIVE ARM INTO SLIDE FIRST. THEN PLACE OUTPUT SHAFT & ARM INTO TT XII. INSTALL OUTPUT SHAFT RETAINING BOLT LOOSELY INTO OUTPUT SHAFT FROM OPPOSITE SIDE OF TT XII (AS SHOWN).

5. REMOVE PROTECTIVE STRIP FROM ENCODER, CONNECT POWER, PLACE UNIT INTO HOLD OPEN FOR PRELOADING
6. TIGHTEN DRIVE ARM TO OUTPUT SHAFT, THEN RETAINING BOLT TO OUTPUT SHAFT.
7. PLACE UNIT INTO AUTO AND SEE SECTION 7 (COMMISSIONING THE TTX - II OPERATOR)

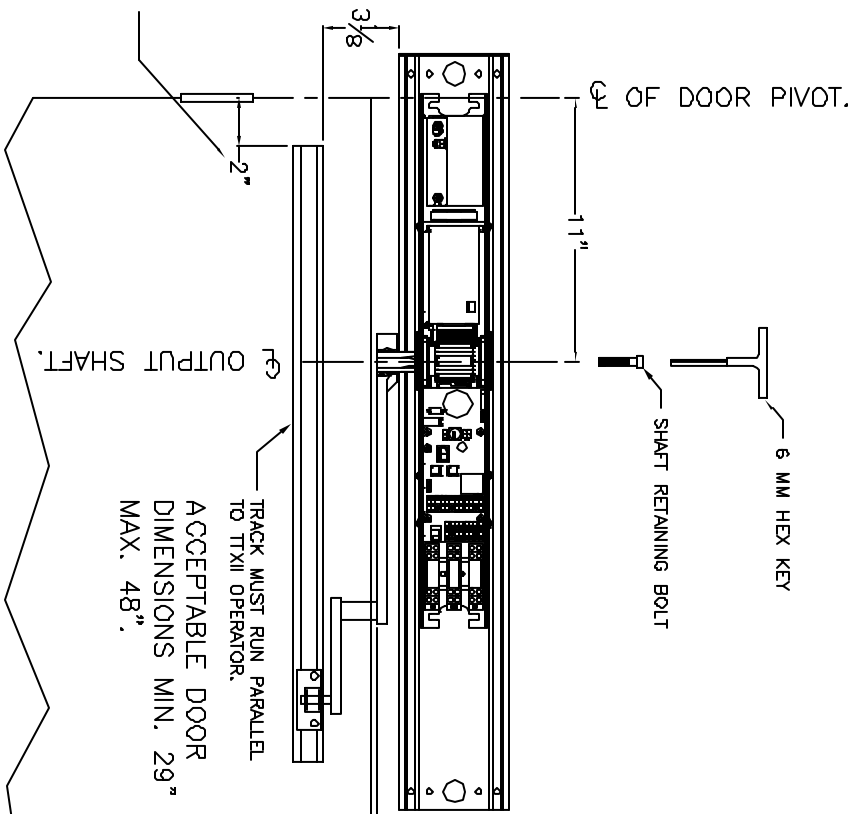

THE 2" DIMENSION IS FOR ZERO REVEAL. ADD 3/4" TO THE 2" DIMENSION ABOVE FOR EVERY 2" OF REVEAL.

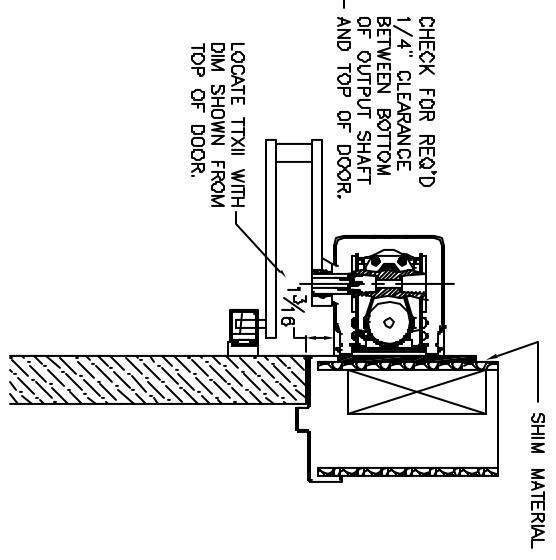

INSWING PARTS LIST

P/N	DESCRIPTION
141020	67mm(2.65") SHAFT
141133	RH DL ARM BLK
141134	LH DL ARM BLK

INSTALLATION DWG. FOR SURFACE MOUNT
TT XII INSWING W/DEEP REVEAL.

- INSTALLATION STEPS FOR INSWING ARM.
NOTE: HEADER LOCATION IS DRIVEN BY CLEARANCE REQUIREMENTS OF THE INSWING ARM.
1. LOCATE TTXII WITH DIMENSIONS SHOWN SO THAT UNIT IS LEVEL. IT MAY BE NECESSARY TO SPACE THE UNIT AWAY FROM WALL WITH PROPER SHIM MATERIAL (AS SHOWN). USE ALL MOUNTING HOLES PROVIDED, WITH CORRECT ANCHORS.
 2. MOUNT SLIDE TRACK WITH DIMENSIONS SHOWN. TRACK MUST BE PARALLEL TO FLOOR UNIT & MOUNTED AS CLOSE TO TOP OF DOOR AS POSSIBLE. SEE ALL PROVIDED MOUNTING LOCATIONS. SLIDE FASTENER COVER INTO PLACE.
 3. INSTALL SLIDE ONTO TRACK WITH SLOTTED SIDE OF COVER FACING UP. SLIDE SHOULD MOVE SMOOTHLY IN TRACK. INSTALL TRACK END CAPS.
 4. INSTALL DRIVE ARM INTO SLIDE FIRST, THEN PLACE OUTPUT SHAFT & ARM INTO TTXII. INSTALL OUTPUT SHAFT RETAINING BOLT LOOSELY INTO THE OUTPUT SHAFT FROM OPPOSITE SIDE OF TTXII (AS SHOWN).

5. REMOVE PROTECTIVE STRIP FROM ENCODER, CONNECT POWER, **PLACE UNIT INTO HOLD OPEN FOR PRELOADING**
6. TIGHTEN DRIVE ARM TO OUTPUT SHAFT, THEN RETAINING BOLT TO OUTPUT SHAFT.
7. PLACE UNIT **INTO AUTO AND SEE SECTION 7 (COMMISSIONING THE TTX - II OPERATOR)**

- INSTALLATION STEPS FOR OUTSWING ARM.
1. LOCATE TTXII WITH DIMENSIONS SHOWN SO THAT UNIT IS LEVEL. IT MAY BE NECESSARY TO SPACE THE UNIT AWAY FROM WALL WITH PROPER SHIM MATERIAL (AS SHOWN). USE ALL MOUNTING HOLES PROVIDED, WITH CORRECT ANCHORS.
 2. REMOVE PROTECTIVE STRIP FROM ENCODER AND CONNECT POWER. **PLACE UNIT INTO HOLD OPEN. ONCE MOTOR HAS ROTATED APPROX. 20 DEG, INSTALL OUTPUT SHAFT AS SHOWN WITH SURFACES A & B RUNNING PARALLEL WITH EACH OTHER AND TORQUE OUTPUT SHAFT TO 30 FT. - LBS.**
 3. CONNECT DRIVE ARM OPERATOR PORTION TO OUTPUT SHAFT AS SHOWN. MOUNT DOOR PORTION AS REQUIRED AND ADJUST LENGTH TO KEEP DOOR IN THE CLOSED POSITION.
 4. PLACE UNIT **INTO AUTO AND SEE SECTION 7 (COMMISSIONING THE TTX - II OPERATOR)**

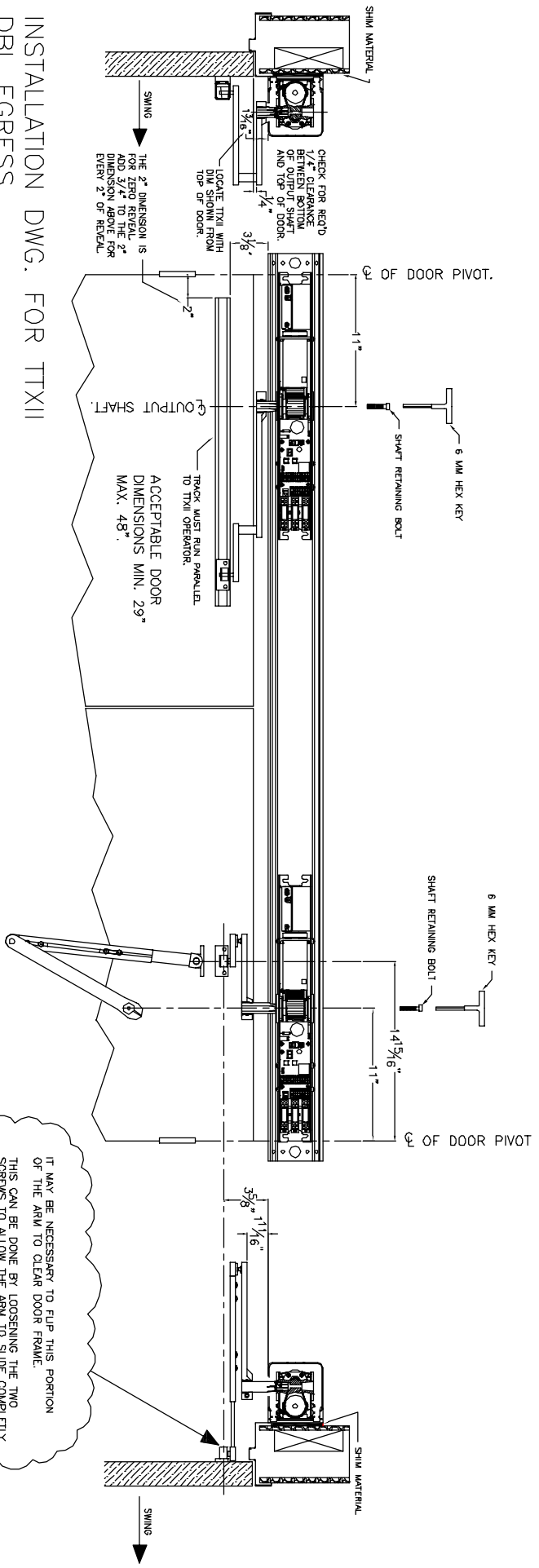

INSTALLATION DWG. FOR TTXII
DBL EGRESS.

INSWING PARTS LIST

P/N	DESCRIPTION
141020	67mm(2.65") SHAFT
141133	RH DL ARM BLK
141134	LH DL ARM BLK

OUTSWING PARTS LIST

P/N	DESCRIPTION
141106-A	100mm(4") SHAFT
405648	ARM ASSEMBLY DRK BRONZE

IT MAY BE NECESSARY TO FLIP THIS PORTION OF THE ARM TO CLEAR DOOR FRAME. THIS CAN BE DONE BY LOOSENING THE TWO SCREWS TO ALLOW THE ARM TO SLIDE COMPLETELY OUT. ROTATE THE SHAFT 180 DEGREES AND RE-INSERT AS SHOWN.

5 Mechanical Adjustments



An external door stop may be installed as shown but you must leave a 3/8" space between the door and any physical stop.



The door should only be opened so far that the standard linkage cannot tip over and the sliding lever does not leave the rail.

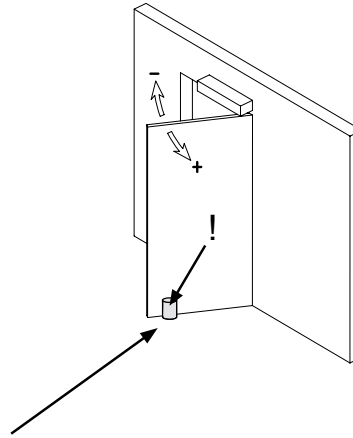
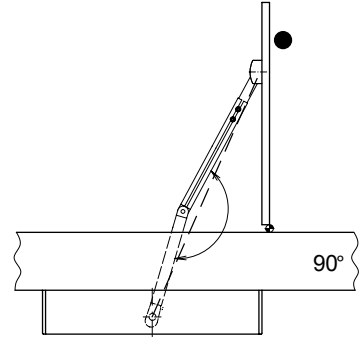
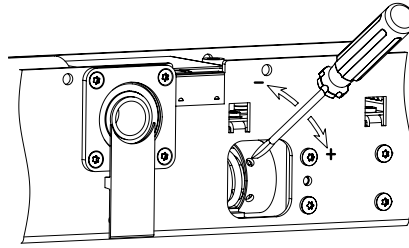

External door stop.

6 Electrical Connections

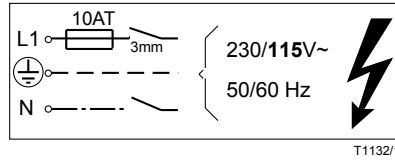

Mains Connection

Before beginning the work described here check that the mains supply is switched off.

If possible, route the mains connection along the side of the power supply to the operator.

The connecting cables must be of the type “PVC cable H05VV-F” or “rubber hose cable H05RR-F”.

Round the edges and remove burrs from all conduits used for the mains connection.

- Remove mains supply cover (1).
- Connect the mains cable to terminal (11) in accordance with figure.
- Route the mains cable either through the prepared holes of the side cover or through the slots in the mounting plate.
- Use only cable bushings made from synthetic materials. Metallic bushings are to be earthed.
- Check correct adjustment of the voltage selector (12) and reinstall the mains supply cover (1).

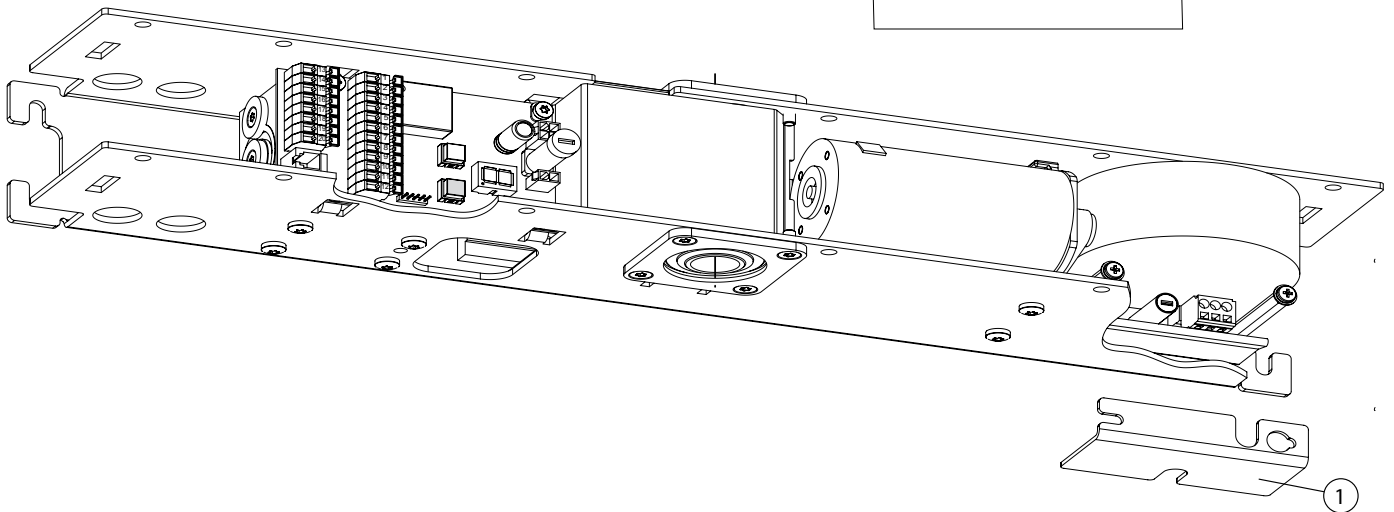
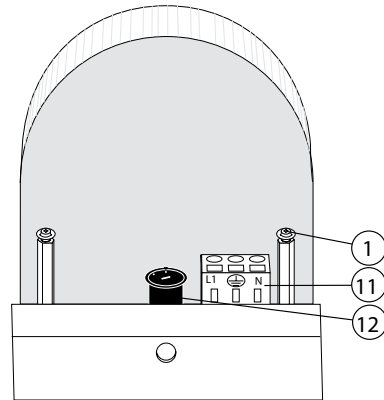

To Reduce the risk of electric shock, it is critical that all wiring

- 1) Be properly Grounded
- 2) Be permanently Fastened
- 3) Satisfy local code requirements.

Terminal Connections

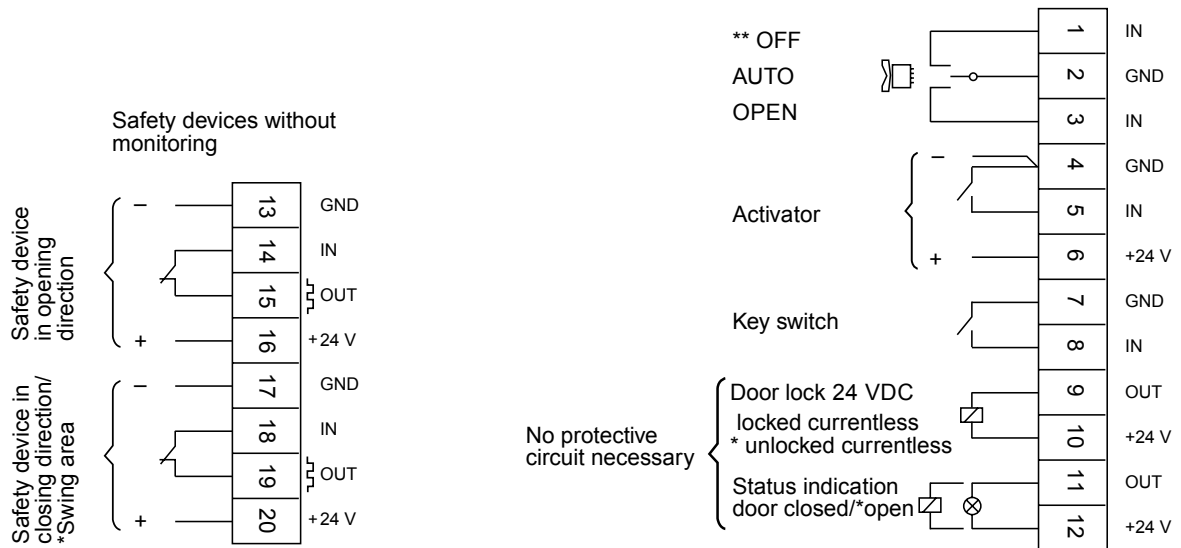

Legend:

- * programmable
- +24 V 24 VDC (21 ... 24 VDC), total max. 0.75 A
- IN Input (contact load 24 VDC / 4 mA)
- OUT Output NPN (max. load 24 VDC/0,75 A) integrated protective diode
- ** Applying an impulse on operating mode OFF (min 0.6 s) interrupts the current hold-open time.

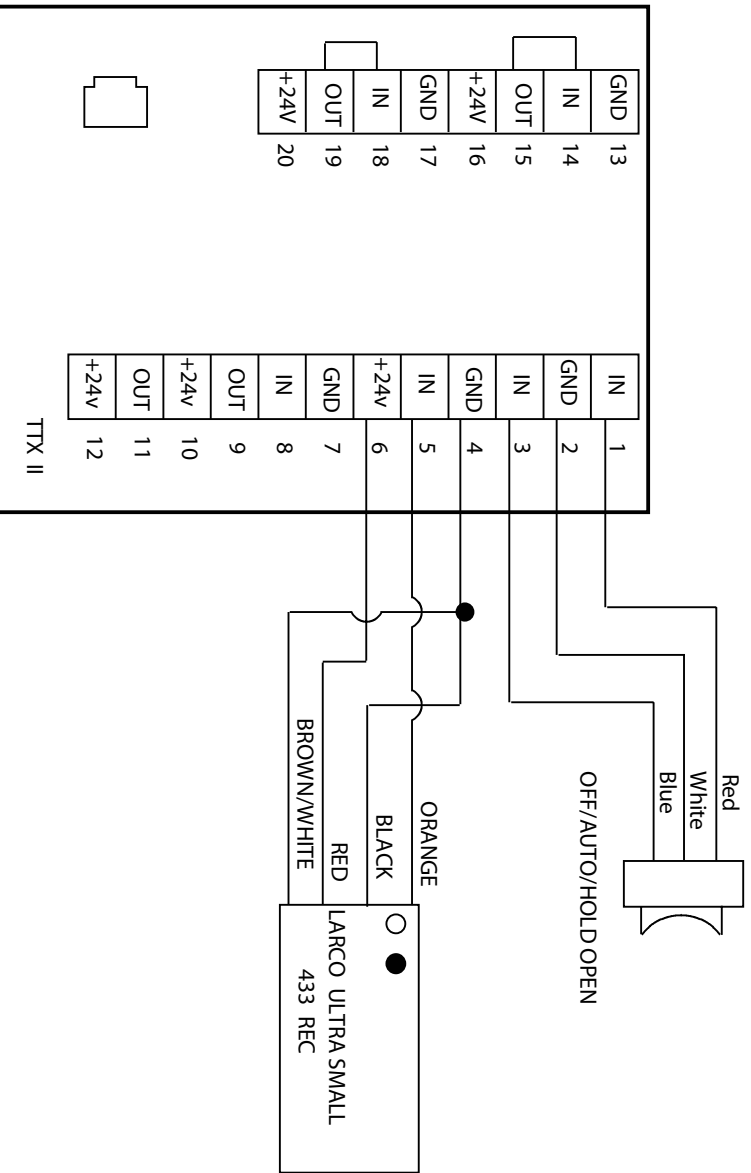

○ ○
 LARCO 433
 TRANSMITTER

Note:

Please see programming matrix on page 25 for setup.

Title:	TTXII WITH LARCO 433 WIRELESS RECEIVER AND TRANSMITTER	
Dwg. by:	Beto Rendon	
Date:	4-3-06	
DWG. NO.:	22d	

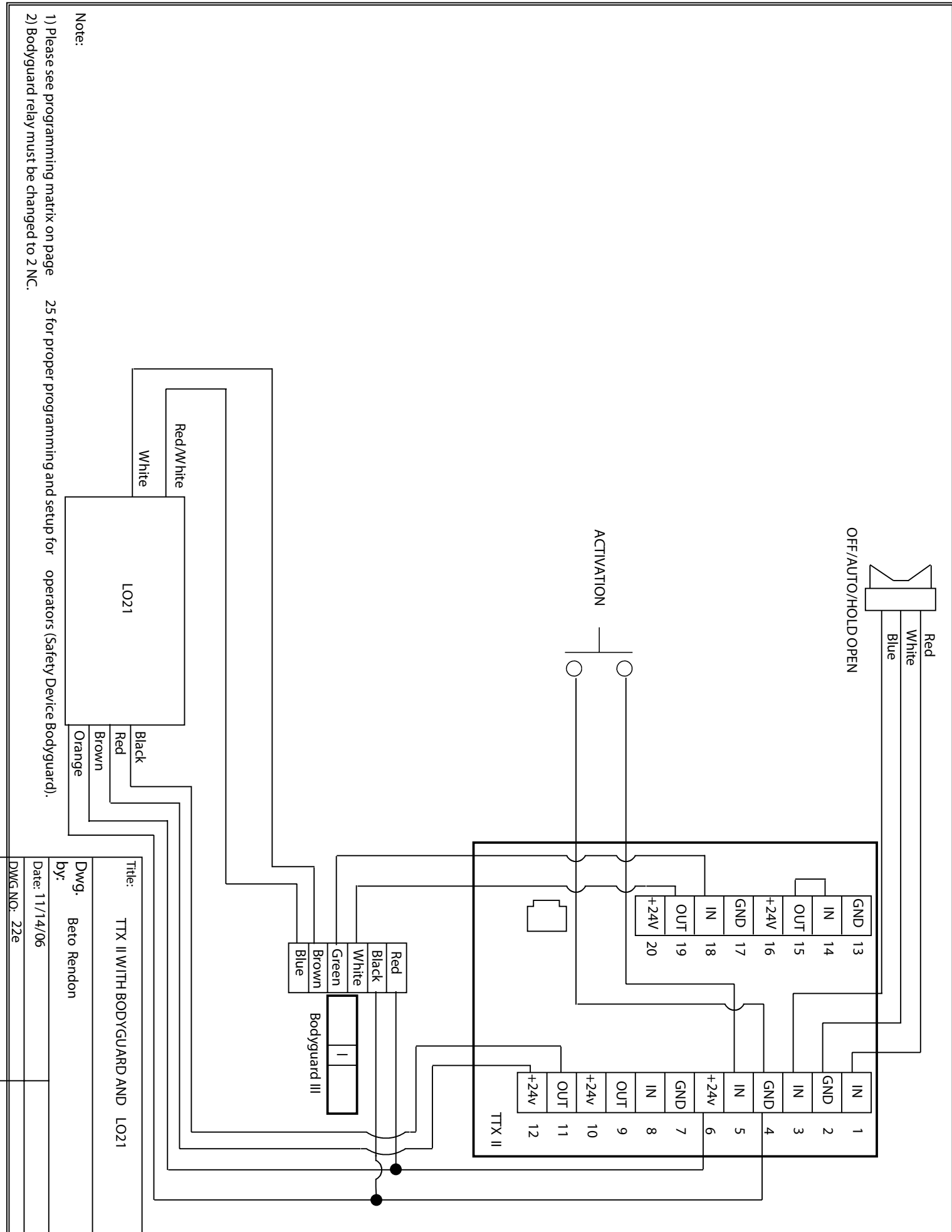

Note:
 1) Please see programming matrix on page 25 for proper programming and setup for operators (Safety Device Bodyguard).
 2) Bodyguard relay must be changed to 2 NC.

Title:	TTX II WITH BODYGUARD AND LO21
Dwg. by:	Beto Rendon
Date:	11/14/06
DWG.NO:	22e

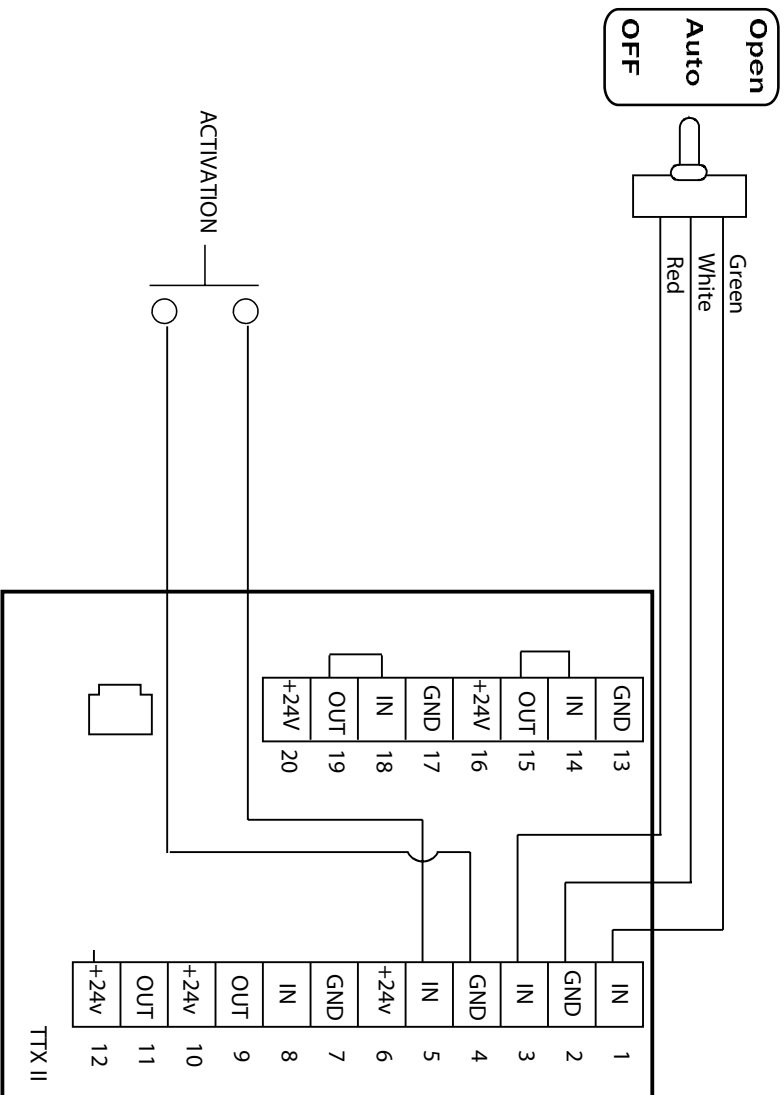



Title: TTXII Btm Load

Dwg. by: Beto Rendon

Date: 2/15/08

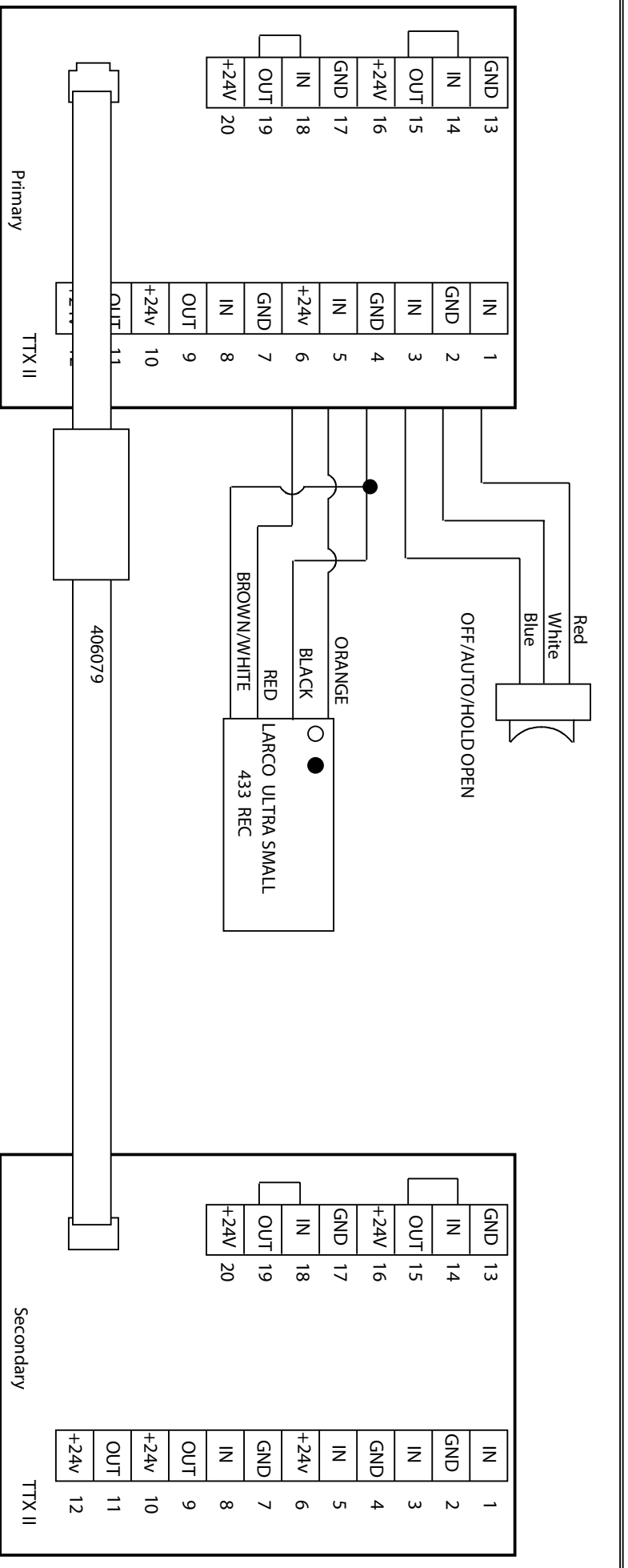
DWG.NO.: 22 L





 LARCO 433
 TRANSMITTER

Note:

See programming matrix on page 25 and programming procedure on page 30.

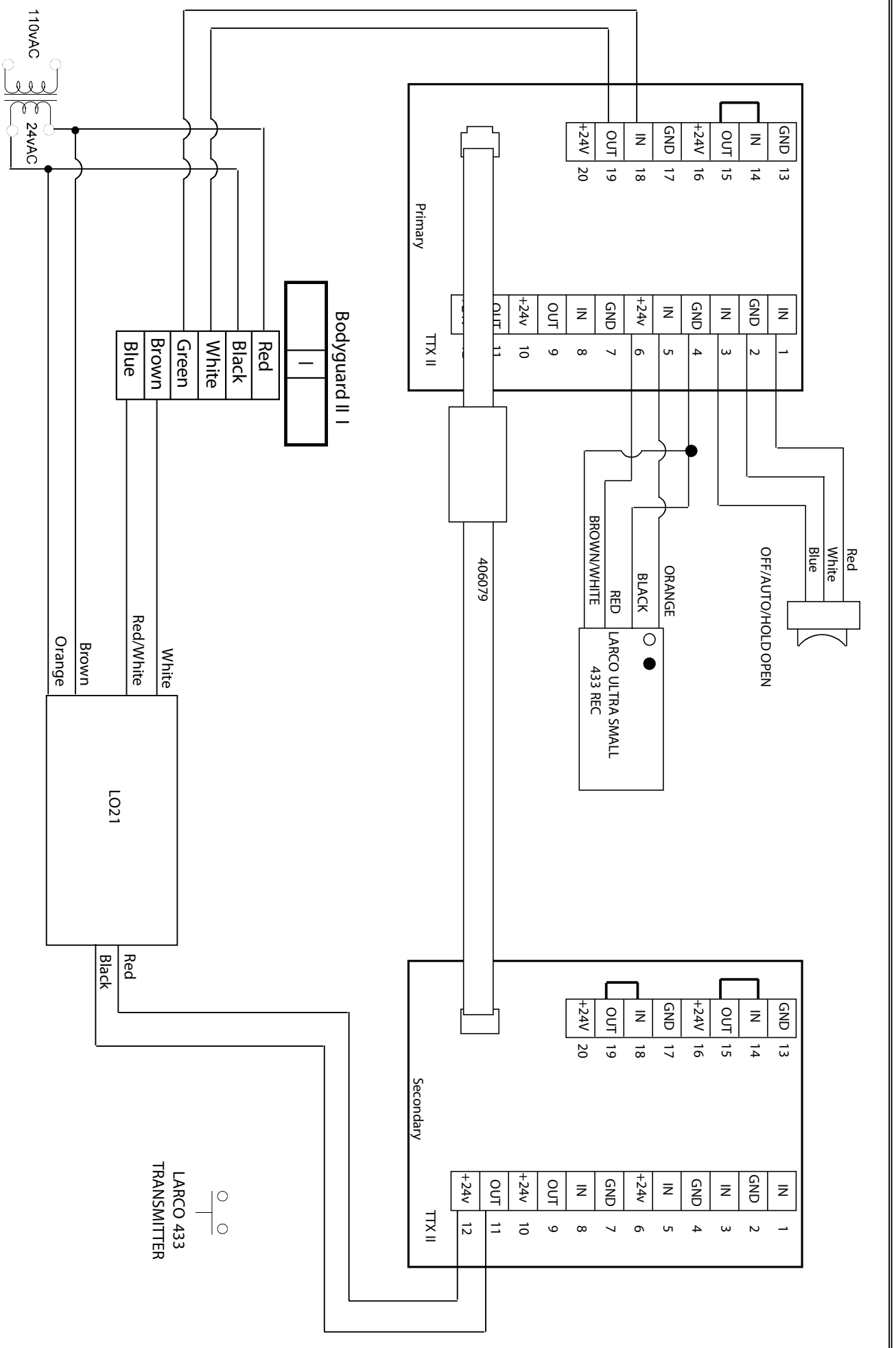
Title:	TT XII PAIR WITH LARCO 433 WIRELESS RECEIVER AND TRANSMITTER
Dwg. by:	Beto Rendon
Date:	2-12-09
DWG NO:	22N



Note:

See programming matrix on page 25 and programming procedure on page 30.
 Set Bodyguard to relay 2 - NC.

Title: TTXII PAIR WITH LO21, BODYGUARD AND 433 WIRELESS RECEIVER.

Dwg. by: Beto Rendon

Date: 2-13-09

DWG NO.: 220

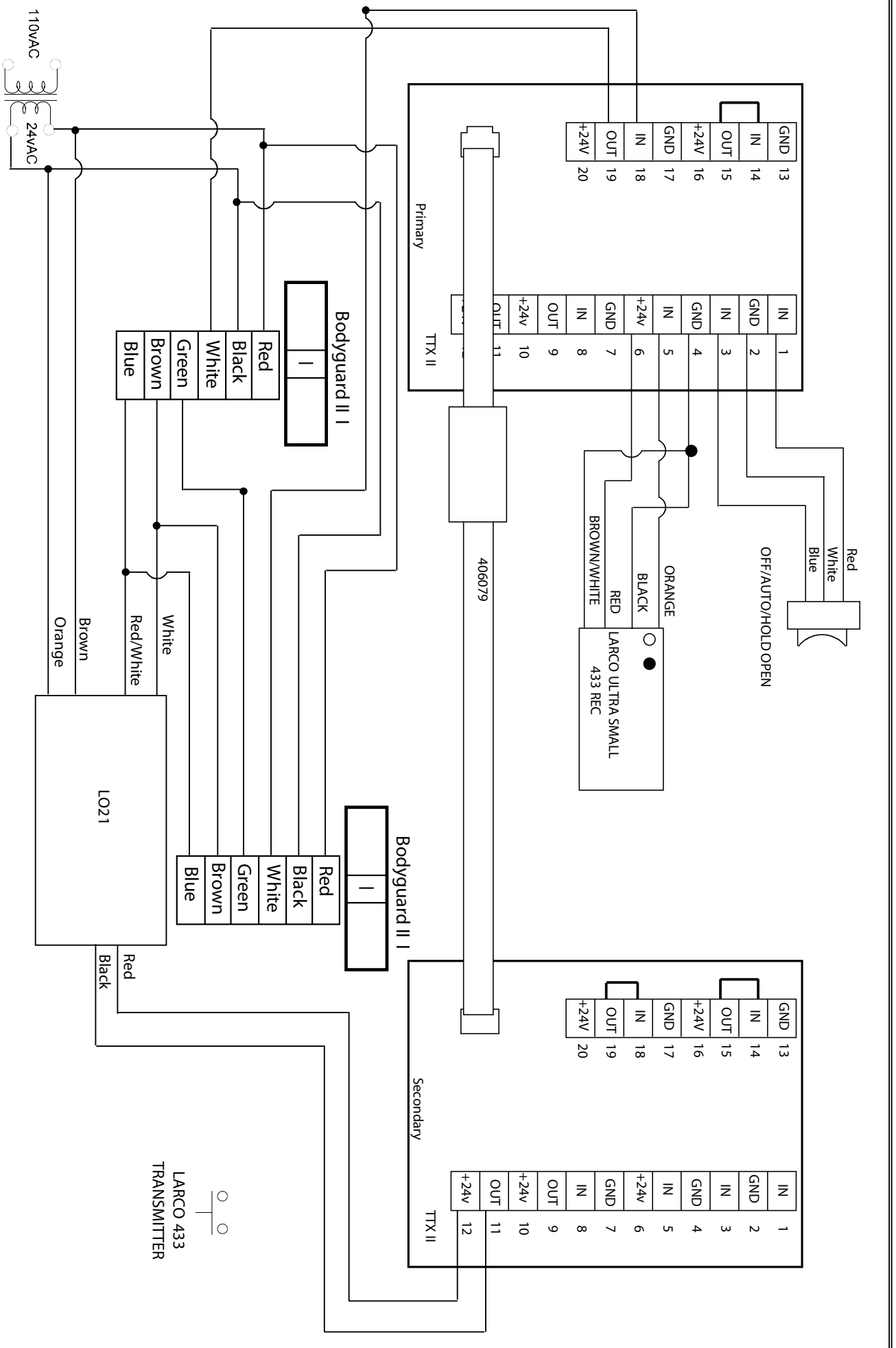

Note:
 See programming matrix on page 25 and programming procedure on page 30.
 Set both Bodyguards to relay 2 - NC.

Title: TTXII DOUBLE EGRESS PAIR WITH LO21,
 BODYGUARDS AND 433 WIRELESS RECEIVER.

Dwg. by: Beto Rendon

Date: 2-13-09

DWG NO: 22P

7 Commissioning the TTXII Operator

Requirements before Commissioning



- The activating devices are installed to the latest ANSI A156.10 and / or A156.19 standard.
- The operator is secured with appropriate fasteners.
- The internal stop is adjusted correctly.
- The all wires are no in the path of moving parts.
- The system is switched to off and the door is in the closed position.
- The point LED at the digital display is illuminated
- * The preload has been preformed and the appropriate arm angle has been set.



7.1 Commissioning with "Teach-In General"



During commissioning and in particular during "Teach-In" no people or items may be present in the swing area of the door!

(Factory Reset Solid 9 flashing "1")

1. Simultaneously press and release the yellow and blue buttons for 1 second, Immediately press the yellow button (step do not hold down) til a solid number 9 is displayed, Immediately press and release the blue button and a flashing "0" will display, Immediately press the yellow button and a flashing "1" will display, Immediately press the blue button and a solid number 9 will be displayed briefly.

(Teach-In Solid 0 flashing "0")

2. Simultaneously press and release the yellow and blue buttons for 1 second, Immediately press the yellow button and a solid 0 will display, Immediately press the blue button and a flashing "0" will display, Immediately open the door to 90 degrees at a fast speed, hold the door open for the amount of hold open time, allow the door to spring close to the full closed position then Immediately push the door open 6" and release, The door will automatically open displaying a flashing "1" for opening A flashing "2" for hold open time Then a flashing "3" for the closeing cycle When the door reaches the full closed position the display will stop flashing and the point LED will display again.

3. The Teach-In is now complete, see the programming table for adjustments and the following examples.



4. Make sure your installation is ANSI A156.10 and / or A156.19 compliant. In addition to this , Operator must be checked to verify
 - a) The door should open without applying power to the unit.
 - b) The force required to open the door should not be greater than 50 pounds (222.54 N) without applying power to the unit.
 - c) The door does not close with a force greater than 40 pounds at the latch side of the closing stile and does not close the final 10 degrees in less than 1.5 seconds.

7.2 Programming Examples

Program the desired functions now in sequence in accordance with the programming table.

- Example 1
- (Turn Push and Pull off Solid 1 Flashing "1")**
1. Simultaneously press and release the yellow and blue buttons for 1 second, Immediately press the yellow button (step do not hold down) til a solid number 1 is displayed, Immediately press and release the blue button and a flashing "0" will display, Immediately press the yellow button and a flashing "1" will display, Immediately press the blue button and a solid number 1 will be displayed briefly.
- Example 2
- (Speed Adjustment Solid 8 Flashing "5")**
2. Simultaneously press and release the yellow and blue buttons for 1 second, Immediately press the yellow button (step do not hold down) til a solid number 8 is displayed, Immediately press and release the blue button and a flashing "0" will display, Immediately press the yellow button (step do not hold down) til a flashing number "5" is displayed, Immediately press the blue button and a solid number 8 will be displayed briefly.
- Example 3
- (Latch Check Speed Solid 6 Flashing "2")**
2. Simultaneously press and release the yellow and blue buttons for 1 second, Immediately press the yellow button (step do not hold down) til a solid number 6 is displayed, Immediately press and release the blue button and a flashing "8" will display, Immediately press the yellow button (step do not hold down) til a flashing number "2" is displayed, Immediately press the blue button and a solid number 6 will be displayed briefly.

7.3 Programming Table

(Teach-In Solid 0 flashing “0”)

Simultaneously press and release the yellow and blue buttons for 1 second, Immediately press the yellow button and a solid 0 will display, Immediately press the blue button and a flashing “0” will display, Immediately open the door to 90 degrees at a fast speed, hold the door open for the amount of hold open time, allow the door to spring close to the full closed position then immediately push the door open 6” and release, The door will automatically open displaying a flashing “1” for opening A flashing “2” for hold open time Then a flashing “3” for the closing cycle When the door reaches the full closed position the display will stop flashing and the point LED will display again.

Solid Numbers = Function			Factory settings									
	Function	Parameter	Factory reset	Primary / Secondary	Special application							
9.	Reset, special functions		Factory reset									
8.	Open and Close speed adjustment governor	ff	min.								max.	
7.	Reverse on Obstruction force	offo	min.								max.	
6.	Close check speed	8	(fast)								(slow)	
5.	Close check angle	12°	4°	8°	12°	16°	20°	24°	28°	32°	36°	
4.	Fail safe output			x		x		x				
	Fail secure output	x			x		x		x			
	Message door OPEN				x		x		x			
	Message door CLOSED	x										
	Step control	x	x				x		x			
3.	Delay time to open	0.2 s	0.4 s	0.8 s	1.2 s	1.6 s	2.0 s	2.4 s	2.8 s	3.2 s	3.6 s	
2.	Reverse on obstruction	x	x	x								
	Safety device bodyguard						x					
	Safety device swing side		x			x						
	Safety device push side	x			x							
1.	Push-and-Go*	1.2°	off	0.3°	0.5°	1.2°	2.4°	4.8°	9.5°	14.4°	19.3°	
0.	Teach-In	5 ... 9 only 0 ... 4 general	motion control**	opening speed	open-position**	hold-open time	closing speed	motion control**	opening speed	open-position**	hold-open time	closing speed

* All angular data is related to the drive shaft, not to door leaf
 ** Removes 2 second delay from Primary / Secondary setup

= Key switch

7.4 Programmable Functions

Function		Parameter	Description of Function
0	Teach-In General	0	Programs the door to your opening specifications Opening and closing speed, open position, hold-open time, disabling angle for safety device in opening direction The behaviour applies to opening through activators, key switches and Push-and-Go. The technician must perform the "Teach-In General" for each operator!
		1	The opening speed of "Teach-In General" is changed.
		2	The hold open position of "Teach-In General" is changed. Caution: The disabling angle for the safety device in opening direction is recognized again.
		3	The hold-open time of "Teach-In General" is changed (max. 100 minutes).
		4	The closing speed of "Teach-In General" is changed (max. 100 minutes).
0	Teach-In key switch	5	Programs the door to a different opening specification to that of Teach-In General, activated by the key switch input (7 - 8). Opening and closing speed, open position, hold-open time. Caution: The disabling angle for the safety device in opening direction is recognized again.
		6	Only the opening speed of the Teach-In key switch is changed
		7	Only the open position of the Teach-In key switch is changed Caution: The disabling angle for the safety device in opening direction is recognized again.
		8	Only the hold-open time of the Teach-In key switch is changed (max. 100 minutes)
		9	Only the closing speed of the Teach-In key switch is changed
1	Push-and-Pull	0	"Push-and-Pull" is switched on. On an attempt to open the door manually the door opens automatically in accordance with "Teach-In General". The preadjusted release angle at the drive shaft is 1.2 °.
		1	Push-and-Go is switched off. No motor-driven opening takes place on an attempt to open the door manually. The door closes in a controlled manner as soon as it is released.
		2...9	Push-and-Pull is switched on. The door opens automatically in accordance with "Teach-In General" on an attempt to open the door manually. The release angle for Push and Pull is adjustable from 0.3 ° to 19.3 °, measured at the shaft of the drive unit.
2	Safety devices with reversing	0	Safety device in closing direction. Input functions as a reactivation sensor and the input is disabled when the door reaches the full closed position.
		1	The safety device for the swing area (e.g. for safety mat) is activated.
		2	The safety device Bodyguard is activated.
	Safety devices with out reversing	3	Safety device in closing direction. Input functions as a reactivation sensor and the input is disabled when the door reaches the full closed position.
		4	The safety device for the swing area (e.g. for safety mat) is activated.
5	The safety device Bodyguard and lock out data is configured for outputs 11 and 12.		
3	Delay time to open	0 ... 9	After an opening command, the door lock is unlocked immediately. The motor is only started on completion of the opening time delay so that the door has sufficient time to unlock. The opening time delay is adjustable from 0.2 to 3.6 s.
4	Special functions	0...7	In this adjustment menu, 3 different functions can be selected in combination according to the specifications in the programming table: 1. Sequencing according to time or step control 2. Door lock fail safe or fail secure 3. Feedback of door state: „door closed“ or „door open“
5	Close check angle	1...9	The close check angle can be adjusted to begin from 4 deg to 36 deg of shaft rotation. (0 = standard value 12 deg)
6	Close check speed	1...9	The homing in speed closing is effective from angle homing in speed closing and is thus dependent on this setting. The homing in speed can be adjusted between a minimum, e.g. end stop for door lock, and maximum homing in speed for softly driving to the final position. (0 = standard value with medium homing in speed)
7	Reverse on obstruction	0...9	This setting affects the amount of force the operator will apply before the opening cycle is cancelled. (0 = standard value without force limitation)

Function		Parameter	Description of Function
8	Open and closing speed adjustment	0..9	This adjustment is a governor for the opening and closing speed. It is recommended the speed during Teach-In General be performed fast and then use this adjustment as governor to limit the opening and closing speeds. (0 = standard value without speed limitation)
	Factory Reset	1	With the factory reset, all programming changes made are reset to the default values and the home position is re-defined. A Teach-In General must be performed again.
9	Paired application	2	The primary operator is defined when using in a paired configuration (see section 7.6).
	Reset + Special Functions	3	No function
	reserved	4	
	reserved	5	
	reserved	6	
	Opening delay on paired applications	7	Toggles the opening delay between the primary and secondary operators, must be done to both paired operators.

7.5 Simultaneous pairs or Double Egress doors

Electrical Connections

As described in Chapter 6, the following instructions also apply:

- Always operate both units directly connected to the same power supply (L1, N, PE). Both units must have the same earth ground!
- So that data can be exchanged between the two control units, both RS232 interfaces must be connected with interface module 406079.

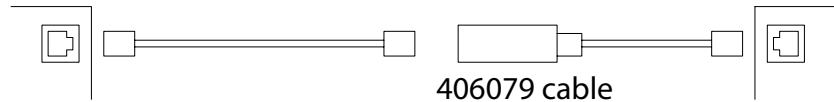

- The HO / Auto / Off switch must be connected to the Primary operator

7.5.1 Simultaneous pairs or Double Egress Commissioning

Primary operator and Secondary operator

(Factory Reset Solid 9 Flashing "1")

1. Simultaneously press and release the yellow and blue buttons for 1 second, immediately press the yellow button (step do not hold down) til a solid number 9 is displayed, immediately press and release the blue button and a flashing "0" will display, immediately press the yellow button and a flashing "1" will display, immediately press the blue button and a solid number 9 will be displayed briefly.

Primary operator

(Primary Teach-In General Solid 9 Flashing "0")

2. Simultaneously press and release the yellow and blue buttons for 1 second, immediately press the yellow button (step do not hold down) til a solid number 9 is displayed, immediately press and release the blue button and a flashing "0" will display, immediately press the yellow button and a flashing "2" will display, immediately press the blue button and a flashing "0" will display, immediately open the door to 90 degrees at a fast speed, hold the door open for the amount of hold open time, allow the door to spring close to the full closed position then immediately push the door open 6" and release, the door will automatically open displaying a flashing "1" for opening. A flashing "2" for hold open time. Then a flashing "3" for the closing cycle. When the door reaches the full closed position the display will stop flashing and the point LED will display again.

See step 3 on next page

Secondary operator

(Teach-In Solid 0 flashing "0")

3. Simultaneously press and release the yellow and blue buttons for 1 second, Immediately press the yellow button and a solid 0 will display, Immediately press the blue button and a flashing "0" will display,



(Caution the Primary door will open then close after the Secondary door has been taught in, make sure the door area is free of any obstruction)

Immediately open the door to 90 degrees at a fast speed, hold the door open for the amount of hold open time, allow the door to spring close to the full closed position then Immediately push the door open 6" and release, The door will automatically open displaying a flashing "1" for opening A flashing "2" for hold open time Then a flashing "3" for the closing cycle When the door reaches the full closed position the display will stop flashing and the point LED will display again and the Primary door will close.

(Remove opening delay between operators Solid 9 Flashing "7")

Primary operator
and
Secondary operator

4. Simultaneously press and release the yellow and blue buttons for 1 second, Immediately press the yellow button (step do not hold down) til a solid number 9 is displayed, Immediately press and release the blue button and a flashing "0" will display, Immediately press the yellow button (step do not hold down) til a flashing number "7" is displayed, Immediately press the blue button and a solid number 9 will be displayed briefly,

(Perform the same procedure on both operators)

5. The Teach-In is now complete, see the programming table for adjustments and the following examples.
6. Make sure your installation is ANSI A156.10 and / or A156.19 compliant. In addition to this , Operator must be checked to verify
 - a) The door should open without applying power to the unit.
 - b) The force required to open the door should not be greater than 50 pounds (222.54 N) without applying power to the unit.
 - c) The door does not close with a force greater than 40 pounds at the latch side of the closing stile and does not close the final 10 degrees in less than 1.5 seconds.

Programming behavior
for paired applications

No.	Function	Comments
0	Teach-In	The hold-open time is determined by the Primary unit for both doors. If a Teach-In is run on the Primary again in order to alter the motion on this door, the Primary opens first of all so that the process cannot interfere with the door leaves overlapping at any time.
1	Push-and-Pull	Separately adjustable.
2	Safety devices	The safety systems in the opening direction are separately inhibited.
4	Time / step control, message, lock type	Time / step control only adjustable on Primary. The message and the lock type can be adjusted separately
5	Close check	Separately adjustable.
6	Close check speed	Separately adjustable.
7	Reverse on Obstruction	Separately adjustable.
8	Speed adjustment	Separately adjustable.
9	Factoryreset	Separately adjustable.

8 Trouble shooting

Fault pattern	Cause
Door doesn't open	<ul style="list-style-type: none"> – Safety device in opening direction is active or the cable is interrupted or jumper 14-15 is missing – The safety device for the swing area is active or the cable is interrupted or jumper 18–19 is missing – Operating mode OFF is active or the cable on 1 is short circuited against GND. – Mains supply is interrupted (☒ point LED on the display is not lit anymore) – Power supply 24 V is overloaded (☒ point LED on the display is not lit anymore) – Thermal motor protection was triggered (☒ point LED on the display is not lit anymore) – Thermal protection transformer was triggered (☒ point LED on the display is not lit anymore) – Door lock is blocked – Door lock or the cable is defective – Door lock is incorrectly programmed (function 4 current-free locked / current-free unlocked) – Opening time delay is set too briefly (function 3) – Opening force is limited too much (function 7) or is inadequate for a door that is difficult to operate
Door does not open to full open position	<ul style="list-style-type: none"> – Opening force is too strongly limited (function 7) or is inadequate for a door that is difficult to operate – The safety device in opening direction is triggered during the opening motion (disabling of „Teach-In General“ or „Teach-In Key Switch“). – „Teach-In General“ was not performed – Open position was set according to „Teach-In“ – Internal stop does not permit a larger opening – Irregularity in the opening-versus-force dependency or wind load – Mechanical obstruction
Door opens varyingly	<ul style="list-style-type: none"> – Varying preconditions through „Teach-In General“ and „Teach-In Key Switch“ – Irregularity in the opening-versus-force dependency or wind load
Door remains open	<ul style="list-style-type: none"> – Activator has maintained contact or the cable on 5 is short circuited against GND – Operating mode OPEN is active or cable on 3 is short circuited against GND – The safety device in closing direction is active or the cable is interrupted or jumper 18–19 is missing – The safety device for the swing area is active or the cable is interrupted or jumper 18–19 is missing – Ball screw spindle defective
Door does not remain open in operating mode OPEN	<ul style="list-style-type: none"> – Internal stop incorrectly adjusted – Wind load or door is not in the plumb bob – Motor thermal protection triggered (temporarily only manual operation possible)
The safety device in opening direction does not react	<ul style="list-style-type: none"> – The safety device in opening direction was active during „Teach-In General“ or „Teach-In Key Switch“ – Short circuit in the cable to the safety sensor
Point LED goes out temporarily	<ul style="list-style-type: none"> – Temporary overload >0.75 A at the 24 VDC power supply. In particular when operating the door lock or the signal lamp (cold start)
Door slams shut	<ul style="list-style-type: none"> – Close check speed misadjusted. – Differential pressure in the building – Operator defective (position sensor, motor) – Arm adjustment has changed.
Irregular motion	<ul style="list-style-type: none"> – Operator defective (position sensor, control system, motor) – Ball screw spindle defective
Door closes slowly	<ul style="list-style-type: none"> – Safety activator or cable defective, test of monitored safety devices negativ.
Paired applications Secondary does not open	<ul style="list-style-type: none"> – Commissioning not complete, see chapter 7.6 – Cable connection RS232 disconnected, cable set not completely adopted. – Operator switched off. – Both drives not connected to the same ground
Paired applications Primary does not open	<ul style="list-style-type: none"> – Cable connection RS232 disconnected (no message from secondary for at least min. 4 minutes)
Door always reverses to the CLOSED position	<ul style="list-style-type: none"> – The connection from the linkage to the drive has moved (spindle)
The door does not close completely	<ul style="list-style-type: none"> – The connection from the linkage to the drive has moved (spindle) – The arm was not installed to dimensions.



Your First Choice for Door Automation

TORMAX Sliding Doors

TORMAX Swing Doors

TORMAX Folding Doors

TORMAX Revolving Doors

TORMAX Slide-Swing Doors

TORMAX TECHNOLOGIES, INC.

12859 Wetmore Road

San Antonio, TX 78247

210-494-3551

210-494-5930 (FAX)

888-685-3707

WWW.TORMAXUSA.COM

INFO@TORMAXUSA.COM